



TOWER CRANE GHD4015

(1.2m mast)

Operating Instructions



Contents

Record book Chapter 0	
0.1 Master sheet Manufacturer	4
0.2 Preliminary remark	5
0.3 EC -manufacturer's Declaration	7
0.4 General data, driven motors and gears	8
0.5 Electric control, brakes and accessories	9
0.6 Ropes and load hook	10
Fundamental safety instructions Chapter 1	
1.1 Warnings and symbols	12
1.2 Basic operation and designated use	12
1.3 Organizational measures	13
1.4 Selection and qualification of personnel - basic responsibilities	14
1.5 Safety instructions governing specific operational phases	15
1.6 Transporting the slewing tower crane	17
1.7 Maintenance of the slewing tower crane	17
1.8 Warning of special dangers	19
1.9 Hydraulic and pneumatic equipment	20
1.10 Noise	20
1.11 Oil, grease and other chemical substances	20
1.12 Measuring system	21
Technical data Chapter 2	
2.1 General	24
2.2 Foundation loadings	34
General instructions for assembly Chapter 3	
3.1 Introduction	52
3.2 Ground consistency	52
3.3 Crane installation area	52
3.4 More cranes on the site	52
3.5 Inspection of the building yard	53
3.6 General instruction for crane operator and assembly team	54
3.7 Unallowed crane moves	56
3.8 Assembly and disassembly advices	56
Assembly Chapter 4	
4.1 General assembly information	61
4.2 Erection crane tower (1.2m)	68
4.3 Installing chassis	76
4.4 Assembling the telescopic cage	86
4.5 Anchorage frame 1.2m	101
4.6 Climbing inside the building	109
Safety device Chapter 5	
5.1 General	130
5.2 Position of safety devices	130
5.3 Automatically zero positioning	131
5.4 Dead-man switch	131
5.5 Hoist limit switch	131
5.6 Luffing limit switch	132
5.7 Load moment limiter	132
5.8 Rope retaining brackets	133
5.9 Load hook	133
5.10 Slewing unit – counterweight protection	133

5.11	Lead-in	132
<hr/>		
Crane operation	Chapter 6	
6.1	Prior to initial crane operation	135
6.2	Taking the crane into operation	135
6.3	Crane control desk 15 kW hoist, 15 kW luffing.....	136
6.4	Control of hoist unit.....	137
6.5	Control of luffing unit.....	138
6.6	Control of slewing unit.....	139
6.7	Instructions for crane operation	139
6.8	Taking the crane out of operation.....	140
6.9	Taking the crane out of operation when a gale is approaching	141
6.10	Changing of the hoist rope reeving from 4-fall rope to 2-fall operation	143
Maintenance	Chapter 7	
7.1	Lubrication - General	146
7.2	Oil change intervals.....	146
7.3	Position of lubrication points.....	147
7.4	Lubrication plan.....	147
7.5	Lubricants, operation liquid, quantity	149
7.6	Gear oil	150
7.7	Maintenance schedule	151
7.8	Motors and generators.....	152
7.9	Luffing gear	153
7.10	Luffing brake	154
7.11	Switch cabinet - control house	154
7.12	Electrical cables	155
7.13	Contactors and switch contacts	155
7.14	Emergency limit switches	155
7.15	Slewing ring.....	155
7.16	Shorter lubrication intervals.....	156
7.17	Steel structure.....	156
7.18	Inspection and maintenance of the painting.....	156
7.19	Supervision of forged load hooks as per DIN 15 401	156
7.20	Rope maintenance.....	157
7.21	Time for replacing wire ropes	158
7.22	Drawing-in wire ropes.....	159



Record book

Chapter 0

0.1	Master sheet Manufacturer.....	4
0.2	Preliminary remark.....	5
0.3	EC -manufacturer's Declaration.....	7
0.4	General data, driven motors and gears.....	8
0.5	Electric control, brakes and accessories.....	9
0.6	Ropes and load hook.....	10

0.1 Master sheet Manufacturer

Type:	GHD4015-6
Serial No.:	KN26-0203
Year of manufacture:	2026
Classification according ISO 4301 (FEM-DIN 15018):	A3
Type of crane according DIN 15001, sheet 1:	Crane with luffing jib
Application of crane according DIN 15002, sheet 2:	Tower crane
Kind of operation:	Fixing control station
_____	(Manufacturer)

0.2 Preliminary remark

When carrying out inspections on tower cranes the following shall be observed:

- The national accident prevention rules.
- Standards and Directives.
- The completeness of the crane test record book (the existence of all sheets indicated) shall be checked by the experienced technicians or expert engineers (see ISO 9927-1). The crane test record book shall be completed accordingly.
- Repeat order of blank sheets for the periodical inspection is possible.

Inspections

Inspections prior to first use and after major modifications:

1. The user shall ensure that power driven cranes are tested by an expert engineer before being operated for the first time or before return to service following major modifications. Sentence 1 applies also to other cranes with a load capacity exceeding 1000 kg.
2. Testing prior to first use of a new crane as required by Para. 1 include correct assembling, equipment and readiness for commissioning.
3. Testing before initial operation of a new crane as required by Para. 1 is not necessary if the crane is delivered ready for commissioning and accompanied by evidence of type testing (EC type-Examination) or the EC-Declaration of conformity.

Periodic inspections

1. The user shall ensure that in accordance with their operating conditions and local circumstances at appropriate intervals, but at least once a year, cranes are subjected to all necessary inspections by an experienced technician. The user shall further ensure, that tower crane is inspected by an experienced technician each time they are erected or converted to a new configuration.
2. The user shall ensure, that
 - a) power driven tower cranes
 - b) power driven mobile cranes,
 - c) power driven derrick cranes, which change their places of operation,
 - d) truck-mounted loading cranesare inspected by an expert engineer at least every 4 years.
3. The user shall ensure, that power driven cranes beyond Para. 2 are inspected in the 18th year and then each year by an expert engineer.
4. Para. 2 does not apply for permanent erected truck-mounted loading cranes.

Crane test record book

1. The user shall ensure that the results of the inspections carried out as specified above are entered into a test record book.

Expert engineer

These can be member of a government run or authorised technical inspecting office or persons nominated by the industrial insurance authorities. These inspections do not cover other required by authorities, e. g. the highway code.

0.3 EC -manufacturer's Declaration

Manufacturer's Declaration

In conformity with the directive for machines 98/37/ EC Attachment IIB We, herewith declare that the design of the below described components, in the execution they are supplied, are determined for installation in a crane and that it is forbidden to take the crane into operation until it has been proved that the components which are to be installed in the crane are in accordance with the determinations comprised in the EC directive for machines 98 / 37 / EC.

Designation of machine / part machine / machine part	Construction crane with luffing jib
Manufacturer / Type	GHD4015-6
Serial No.	KN26-0203
Year of manufacture	2026
Applied harmonized standards:	EN 292-1 and EN 292-2 DIN EN 60204-part 32
Applied national standards and technical specifications	rules applicable in Germany until date, according to Machine Directory Oct. 92 to GSG
particularly:	ISO 4301 DIN 15018 / DIN 18800 DIN 15020 BGV D 6

Examination of the actual applications of the related harmonized standards, see above and confirmation that all documents are in accordance with the regulations as per attachment VI.

Place / Date / Signature

Specifications for signer:

0.4 General data, driven motors and gears

General data			Safety device	
Type	GHD4015-6		Maximum load limiter	existent
Jib	Horizontal	/	Load moment limiter	existent
	Luffing	existent	Warning device	Horn
Radius	40 m			Light
Capacity	1.5 t		Hook locking	existent
Position cabin	Turntable		Hoist emergency limit switch	existent
Driven kind	El. motor		Inclination limit switch	existent
Power: Alternative current	380V-50 Hz / 440V-60Hz		Luffing emergency limit switch	existent
Control voltage	110 V - 50 Hz			
Construction weight	31970 kg			

Motors

	Power kW	HZ	Duty cycle %	Type	Degree of protection	Position	r.p.m. U/min
Hoist unit	24	50	40	30QP15HB	IP 54	B3	1400/740 /200
Slewing unit	5.5	50	40	YTRVFW132M1-4F1	IPW23	V 1	1500
Luffing unit	24	50	60	33LP20HA	IP 24	M4 B	1470

Gears

	Type	Transmission	Remarks
Hoist unit	30QP15HB	30.57	
Slewing unit	JH08	177	m= 10; Z =12
Luffing unit	33LP20HA	34.27	

0.5 Electric control, brakes and accessories

	Control house			
	Kind	Circuit diagram-No.:	Power	Serial-No.:
Feeding part	Contacto contr.	4015-6	34 kW / 380 V	
Hoist unit	Contacto contr.			
Slewing unit	Contacto contr.			
Luffing unit	Contacto contr.			
	Brakes			Brake moment Nm
	Kind	Type		
Hoist unit	Disc brake	30QP15HB	500	
Slewing unit	Disc brake Eddy current brake	YTRVFW132M1-4F1	40	
Luffing unit	Disc brake	33LP20HA	500	
Luffing unit emergency	Disc brake	SBD50-20	5000	

	Accessories		
		Type	Remarks
Slewing ring	m=10 Z = 125	011.40.1250.101.24.15	
Torque Limiter		SH-1000T	
Height Limit		DXZ-274	
Luffing Limit		DXZ-210	
Slewing Limit		DXZ-46	

0.6 Ropes and load hook

Ropes					
Application	d mm	Length m	Construction of the rope	Manufacturer	Remarks
Hoisting rope	12	450	35Wx7-1960-12	JIANGSU CITY SAFETY STEEL ROPE CO., LTD	Min. breaking load 101.6kN
Luffing rope	14	160	6x29Fi+IWR-1870 - 14		Min. breaking load 130.5kN

Load hook

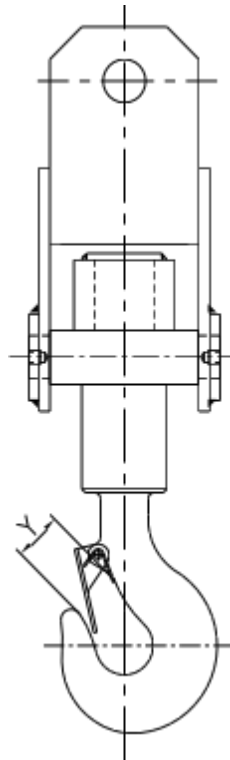

Application	Classification	Y mm	Capacity t	Manufacturer
Hoist unit		63	6	Taizhou Zhenghua Rubber Belt CO., LTD.



Fundamental safety instructions

Chapter 1

1.1	<i>Warnings and symbols</i>	12
1.2	<i>Basic operation and designated use</i>	12
1.3	<i>Organizational measures</i>	13
1.4	<i>Selection and qualification of personnel - basic responsibilities</i>	14
1.5	<i>Safety instructions governing specific operational phases</i>	15
1.6	<i>Transporting the slewing tower crane</i>	17
1.7	<i>Maintenance of the slewing tower crane</i>	17
1.8	<i>Warning of special dangers</i>	19
1.9	<i>Hydraulic and pneumatic equipment</i>	20
1.10	<i>Noise</i>	20
1.11	<i>Oil, grease and other chemical substances</i>	20
1.12	<i>Measuring system</i>	21

1.1 Warnings and symbols

Do not operate the crane if the instructions and procedures outlined in the manual are not clearly understood. Should there be any doubt, ask for the intervention of technical service.

Cranes GH reserves the right to make changes to specifications or to modify the crane at any time without prior notice.

The following signs and designations are used in the manual to designate instructions of particular importance.



Danger - refers to orders and prohibitions designed to prevent injury or extensive damage.



Forbidden - important note to prevent accidents or heavy material damages.

USE OF THE CRANE

Cranes hoisting machines model are tower cranes with upper slewing. They are devised only and exclusively for lifting, luffing and lowering loads as described and specified in this manual.

The use and configuration of the crane described in this manual are the only ones approved by the manufacturer. The crane must only be used according to the instructions herein.

The intended uses of the crane can be assured only if its structural and mechanical components are properly maintained and all systems are working well.

1.2 Basic operation and designated use

1.2.1 The slewing tower crane has been built in accordance with state-of-the-art standards and the recognized safety rules. Nevertheless, its use may constitute a risk to life and limb of the user or of third parties, or cause damage to the machine and to other material property.

1.2.2 The slewing tower crane must only be used in technically perfect condition in accordance with its designated use and the instructions set out in the operating manual, and only by safety-conscious persons who are fully aware of the risks involved in operation. Any functional disorders, especially those affecting safety, should therefore be rectified immediately.

1.2.3 The slewing tower crane is designed exclusively for the lifting and lowering and horizontal transport of loads freely suspended from the load hook. The load may be picked up only from a firm base.

Operating the machine within the limits of its designated use also involves observing the instructions set out in the operating manual and complying with the inspection and maintenance directives.

Product-relevant / Repetition essential as special safety warning/concrete safety warning. Information for the user enterprise and its personnel authorized to give instructions for the operating personnel.

1.3 Organizational measures

1.3.1 The operating instructions must always be at hand at the place of use of the slewing tower crane (in the tool compartment or tool-box provided for that purpose).

1.3.2 In addition to the operating instructions, observe and instruct the user in all other generally applicable legal and other mandatory regulations relevant to accident prevention and environmental protection.

These compulsory regulations may also deal with the handling of hazardous substances, issuing and/or wearing of personal protective equipment, or traffic regulations.

1.3.3 The operating instructions must be supplemented by instructions covering the duties involved in supervising and notifying special organizational features, such as job organization, working sequences or the personnel entrusted with the work.

1.3.4 Personnel entrusted with work on the slewing tower crane must have read the operating instructions and in particular the chapter on safety before beginning work.

Reading the instructions after work has begun is too late. This applies especially to persons working only occasionally on the machine.

1.3.5 Check constantly that the personnel are carrying out the work in compliance with the operating instructions and paying attention to risks and safety factors.

Observe all safety instructions and warnings attached to the slewing tower crane.

1.3.6 In the event of safety-relevant modifications to the slewing tower crane or changes in its behaviour during operation, stop the slewing tower crane immediately and report the malfunction to the competent authority/person.

1.3.7 Never make any modifications, additions or conversions, which might affect safety without the approval of the supplier/manufacturer. This also applies to the installation and adjustment of safety devices as well as to welding work on load-bearing elements.

1.3.8 Product-relevant / Repetition essential as special safety warning/concrete safety warning. Information for the user enterprise and its personnel authorized to give instructions for the operating personnel.

1.3.9 Spare parts must comply with the technical requirements specified by the supplier/manufacturer. Spare parts from original equipment manufacturers can be relied upon to do so. The user must compare the data in the spare-parts catalogue prior to installation of a spare part.

1.3.10 Replace hydraulic hoses and pneumatic lines within stipulated and appropriate intervals even if no safety-relevant defects have been detected.

1.3.11 Prescribed intervals for routine checks and inspections must be adhered to operating instructions.

1.3.12 For the execution of maintenance work, tools and workshop equipment adapted to the task on hand are absolutely indispensable.

1.4 Selection and qualification of personnel - basic responsibilities

1.4.1 Any work on/with the slewing tower crane must be executed by reliable personnel only. Statutory minimum age limits must be observed.

1.4.2 Employ only trained or instructed staff and set out clearly the individual responsibilities of the personnel for operation, transport, assembly, inspection, maintenance, repair and dismantling.

1.4.3 Make sure that only authorized personnel works on the slewing tower crane.

1.4.4 Define the crane operator's responsibilities - also with regard to observing traffic regulations - giving the operator the authority to refuse instructions by third parties that are contrary to safety.

1.4.5 Do not allow persons to be trained or instructed or persons taking part in a general training course to work on or with the slewing tower crane without being permanently supervised by an experienced person.

Product-relevant / Repetition essential as special safety warning/concrete safety warning.

Information for the user enterprise and its personnel authorized to give instructions for the operating personnel.

1.4.6 Work on the electrical system and equipment of the slewing tower crane must be carried out only by a skilled electrician or by instructed persons under the supervision and guidance of a skilled electrician and in accordance with electrical engineering rules and regulations.

1.4.7 Work on mechanical components, such as gearboxes, chassis, braking and steering systems, may be carried out by specially trained personnel only.

1.4.8 Work on hydraulic systems must be carried out only by personnel with special knowledge and experience of hydraulic or pneumatic equipment.

Product-relevant / Repetition essential as special safety warning/concrete safety warning. Information for the user enterprise and its personnel authorized to give instructions for the operating personnel.

1.5 Safety instructions governing specific operational phases

1.5.1 Operation

1.5.2 Observe the regulations applicable to the respective location.

1.5.3 Prior to starting work, get to know the on-site working environment. The working environment includes, for example, obstructions in the working and driving range, the load capacity of the soil and any barriers needed to separate the site from the area accessible to the general public.

1.5.4 Take the necessary precautions to ensure that the slewing tower crane is used only when in a safe and reliable state.

Product-relevant / Repetition essential as special safety warning/concrete safety warning. Information for the user enterprise and its personnel authorized to give instructions. Instructions for the operating personnel.

1.5.5 Before starting up or setting the slewing tower crane in motion, make sure that nobody is at risk.

1.5.6 Operate the slewing tower crane only if all protective and safety-oriented devices, such as removable safety devices, emergency shut-off equipment are in place and fully functional.

1.5.7 Never operate the crane in anyway that might be prejudicial to safety.

1.5.8 During startup and shutdown procedures always watch the indicators in accordance with the operating instructions.

1.5.9 The crane operator must always have a good view of the working range and the load. In poor visibility or darkness, adequate lighting must be provided on the site.

1.5.10 Never work in anyway that might prejudice the stability of the slewing tower crane. The crane steering system must not be switched off when a load is suspended from the hook.

1.5.11 The fastening of loads and the instructing of crane operators should be entrusted to experienced persons only. The marshall giving the instructions must be within sight or sound of the operator.

1.5.12 Check the slewing tower crane at least once per working shift for obvious damage and defects. Report any changes (incl. changes in working behavior) to the competent organization/ person immediately.

If necessary, stop the slewing tower crane immediately and lock it. In the event of malfunctions, stop the slewing tower crane immediately and lock it.

1.5.13 Have any defects rectified immediately.

1.5.14 Always keep tools and loose objects in a safe place.

1.5.15 Keep all handles, steps, handrails, platforms, landings and ladders free from dirt, snow and ice.

Product-relevant / Repetition essential as special safety warning/concrete safety warning.

Information for the user enterprise and its personnel authorized to give instructions.
Instructions for the operating personnel.

1.5.16 Crane operation must be stopped whenever wind-forces are prejudicial to safety. The maximum wind velocity at which the slewing tower crane may be operated is 20 m/s, corresponding to wind-force 8. It should be borne in mind that gusts of wind may reach as much as 20 m/s even with a moderate wind velocity of 12 to 13 m/s (wind-force 6).

1.5.17 When leaving the slewing tower crane, always secure it against inadvertent and unauthorized use and ensure that it is left in the state specified in the operating instructions.

1.5.18 Any other or farther-reaching use, such as

- pulling away loads that are not standing free,
- horizontal movement of loads that are not freely suspended,

- increasing the load after it has already been lifted from the firm ground,
- swinging or vibrating the load,
- any loading beyond the authorized load rating,
- oblique pulling,
- carrying persons on the load or on the load-holding device

is not a designated use and is accordingly prohibited.

1.6 Transporting the slewing tower crane

1.6.1 Prior to transport, check that the transport devices (self-erecting crane), such as axles, brakes, steering, signal and lighting systems, are in working order.

1.6.2 Prior to transporting the slewing tower crane, always check that the accessories are safely stowed away and that all loose parts are fixed.

1.6.3 When driving on any public highways, tracks or places, observe the valid regulations and ensure in advance that the slewing tower crane complies with regulations authorizing the use of vehicles for road traffic.

1.6.4 When driving through underpasses, bridges or tunnels or below overhead power lines, always ensure that there is adequate clearance (headroom).

1.6.5 Never drive with the suspension mechanism transversely positioned. Always keep well clear of building pits and slopes.

1.6.6 Product-relevant / Repetition essential as special safety warning/concrete safety warning.

Information for the user enterprise and its personnel authorized to give instructions. Instructions for the operating personnel.

1.7 Maintenance of the slewing tower crane

1.7.1 Special work in conjunction with utilization of the slewing tower crane and maintenance and repairs during operation; disposal of parts and consumables.

1.7.2 Observe the adjusting, maintenance and inspection activities and intervals set out in the operating instructions, including information on the replacement of parts and equipment. These activities may be executed by skilled personnel only.

1.7.3 Brief operating personnel before beginning special operations and maintenance work, and appoint a person to supervise the activities.

1.7.4 In any work concerning the operation, conversion or adjustment of the slewing tower crane and its safety-oriented devices or any work related to inspection, maintenance and repair, always observe the start-up and shut-down procedures set out in the operating instructions and the information on maintenance work.

1.7.5 Ensure that the maintenance area is adequately secured.

1.7.6 If the slewing tower crane is completely shut down for maintenance and repair work, it must be secured against inadvertent starting by.

1.7.7 - locking the principal control elements and removing the ignition key and/or
- attaching a warning sign to the main switch.

1.7.8 For carrying out overhead assembly and maintenance work always use specially designed or otherwise safety-oriented ladders and working platforms. Never use machine parts as a climbing aid.

1.7.9 If safety devices have to be dismantled in assembly, maintenance or repair work they must be reinstalled and checked immediately on conclusion of the work.

1.7.10 To avoid the risk of accidents, individual parts and large assemblies being moved for replacement purposes should be carefully attached to lifting tackle and secured. Use only suitable and technically perfect lifting gear and suspension systems with adequate lifting capacity.

Product-relevant / Repetition essential as special safety warning/concrete safety warning.

Information for the user enterprise and its personnel authorized to give instructions.
Instructions for the operating personnel.

1.7.11 Never work or stand under suspended loads.

1.7.12 Always tighten any screwed connections that have been loosened during maintenance and repair.

1.7.13 Before cleaning the slewing tower crane with water, steam jet (high-pressure cleaning) or detergents, cover or tape up all openings which - for safety and functional reasons - must be protected against water, steam or detergent penetration. Special care must be taken with electric motors and switchgear cabinets, limit switches, ball bearings and slewing ring.

1.7.14 After cleaning, remove all covers and tapes applied for that purpose.

1.7.15 Rectify any defects immediately. Check that all safety devices are in working order. Check that hydraulic and pneumatic lines are not leaking.

1.7.16 After cleaning, examine all electrical, hydraulic and pneumatic lines for chafe marks and damage.

1.7.17 Ensure that all consumables and replaced parts are disposed of safely and with minimum environmental impact.

Product-relevant / Repetition essential as special safety warning/concrete safety warning.

Information for the user enterprise and its personnel authorized to give instructions.
Instructions for the operating personnel.

1.8 Warning of special dangers

1.8.1 Electric energy

1.8.2 Use only original fuses with the specified current rating.

1.8.3 Keep an adequate distance from overhead power lines with the slewing tower crane. When working close to overhead power lines, the slewing tower crane and its load must not come close to the lines. Keep informed of prescribed safety clearances.

1.8.4 After contacting power lines:

- remain in the slewing tower crane,
- drive the slewing tower crane out of the danger zone,
- warn uninvolved persons not to come nearer or to touch the slewing tower crane,
- have the voltage switched off,
- never leave the slewing tower crane until the contacted/damaged line has been switched off with absolute certainty.

1.8.5 Work on electrical systems or equipment may only be carried out by a skilled electrician himself or by specially instructed personnel under the control and supervision of such an electrician, and in accordance with the applicable electrical engineering rules.

1.8.6 If provided for in the regulations, the power supply to parts of machines and plants, on which maintenance work is to be carried out, must be cut off.

1.8.7 Before starting work, check the de-energized parts for the presence of power and ground or short-circuit them in addition to insulating adjacent live parts and elements.

1.8.8 The electrical equipment of a slewing tower crane is to be inspected at regular intervals.

Defects, such as loose connections or damaged cables, must be rectified immediately,

Product-relevant / Repetition essential as special safety warning/concrete safety warning.

Information for the user enterprise and its personnel authorized to give instructions for the operating personnel.

1.8.9 Necessary work on live parts and elements must be carried out only in the presence of a second person - with whom constant visual and verbal contact must be ensured - who can cut off the power supply in case of danger by actuating the emergency shut-off or main power switch. Secure the working area with a red-and-white safety chain and a warning sign. Use insulated tools only.

- 1.8.10 Before starting work on high-voltage assemblies and after cutting out the power supply, the feeder cable must be grounded and components, such as capacitors, short-circuited with a grounding rod.

1.9 Hydraulic and pneumatic equipment

- 1.9.1 Work on hydraulic and pneumatic equipment may be carried out only by persons with special know-how and experience in hydraulic systems.
- 1.9.2 Check all lines, hoses and screwed connections regularly for leaks and obvious damage. Repair damage immediately. Splashed oil may cause injury, environmental pollution and fire.
- 1.9.3 Depressurize all system sections and pressure pipes (hydraulic system, compressed- air system) to be removed in accordance with the specific instructions for the unit concerned before carrying out any repair work.
- 1.9.4 Hydraulic and compressed-air lines must be laid and fitted properly. Ensure that no connections are interchanged. The fittings, lengths and quality of the hoses must comply with the technical requirements.
- 1.9.5 Product-relevant / Repetition essential as special safety warning/concrete safety warning. Information for the user enterprise and its personnel authorized to give instructions for the operating personnel.

1.10 Noise

- 1.10.1 During operation, all sound baffles on the slewing tower crane must be closed.

1.11 Oil, grease and other chemical substances

- 1.11.1 When handling oil, grease and other chemical substances, observe the product- related safety and environmental protection regulations.
- 1.11.2 Be careful when handling hot consumables (risk of burning or scalding).

Product-relevant / Repetition essential as special safety warning/concrete safety warning.

Information for the user enterprise and its personnel authorized to give instructions.
Instructions for the operating personnel.

1.12 Measuring system

Please note

(structural analysis)

New valid units according to the "SI-unit system".

All data in SI-units are converted and rounded-off values.

off values.

G = Deadweight

P = load

Mass = kg, t

A = Starting force

M = load moment

W = Wind force

Force in N (Newton)

Former unit kp; Mp; dyn

1 kp

10 N = 1 daN*

1 Mp

10 000 N = 10 kN

1 dyn

= 10⁻⁵ N

Torque in Nm (Newtonmeter)

M = Crane moment from G, P, M and W

Former unit kpm

1 Nm

0.10 kpm*

1 kpm

10 Nm = 1 daNm

S = Vertical force per corner strut

Energy, work in kWh (kilowatthours)

W

H_o = Top horizontal force

Former unit PSh (BHPH)

1 kpm

10 Nm = 1 daNm

from M

1 kWh

= 1.36 PSh (HPh)

from Q

Signification of codes and signs

x = Direction of attack parallel to

Y = Direction of attack rectangular to jib

D = Pressure

Z = Pulling force

M_x = Crane moment from G, P, M and W

M_T = Torsion moment from P, G and W

N = Vertical force from G and P

Q = Horizontal force from P, G and

H_u = Bottom horizontal force

H_M = Horizontal force corner strut per

H_Q = Horizontal force corner strut per

H_{MT} = Horizontal force per corner strut from M_T

Power in kW (Kilowatt)

H = Sum of all horizontal forces

E = Maximum strut

force Former unit BHP

1 kW = 1.36BHP *

1 BHP = 0.736 kW

Pressure in bar (Bar)

Former unit kp/cm^2

1 rpm = 1/min

Prefixes are placed without space in front of the unit sign, for example, daNm.

Composite units are written, with interspaces, f.inst.: - Nm -

I The conversion factors are rounded off according to DIN 1 333.



Technical data

Chapter 2

2.1 GENERAL.....	24
2.1.1 CRANE COMPONENTS.....	24
2.1.2 JIB LENGTHS, LOAD DIAGRAMS, SPEEDS.....	25
2.1.3 TOWER CONFIGURATION, HOOK HEIGHTS, ERECTION SEQUENCE...	26
2.1.4 JIB AND TIE BAR CONFIGURATIONS.....	30
2.1.5 INSTALLATION OF THE ROPE SUPPORT WHEEL	31
2.1.6 COUNTER JIB BALLAST.....	31
2.1.7 ROPES DIMENSIONS AND CONSTRUCTIONS HOIST.....	31
2.1.8 PACKING LIST.....	33
2.1.9 BALANCING WEIGHT.....	34
2.2 FOUNDATION LOADINGS.....	35
2.2.1 FOUNDATION LOADINGS.....	35
2.2.2 PREPARATION OF FOUNDATION PLATE.....	36
2.2.3 EARTHING	49
2.2.4 ELECTRIC POWER SUPPLY	49
2.2.5 OUT OF SERVICE.....	50

2.1 General



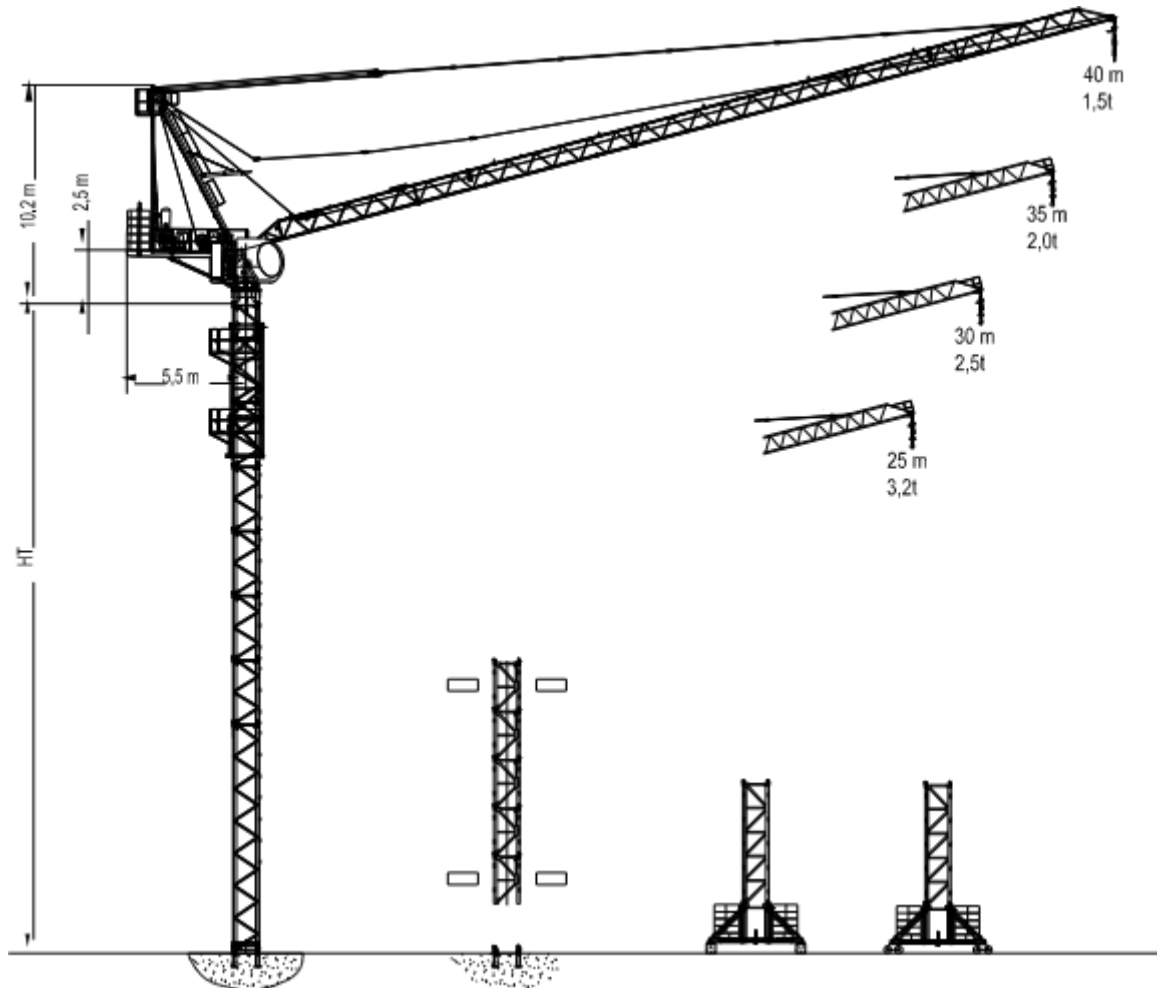



2.1.1 Crane components

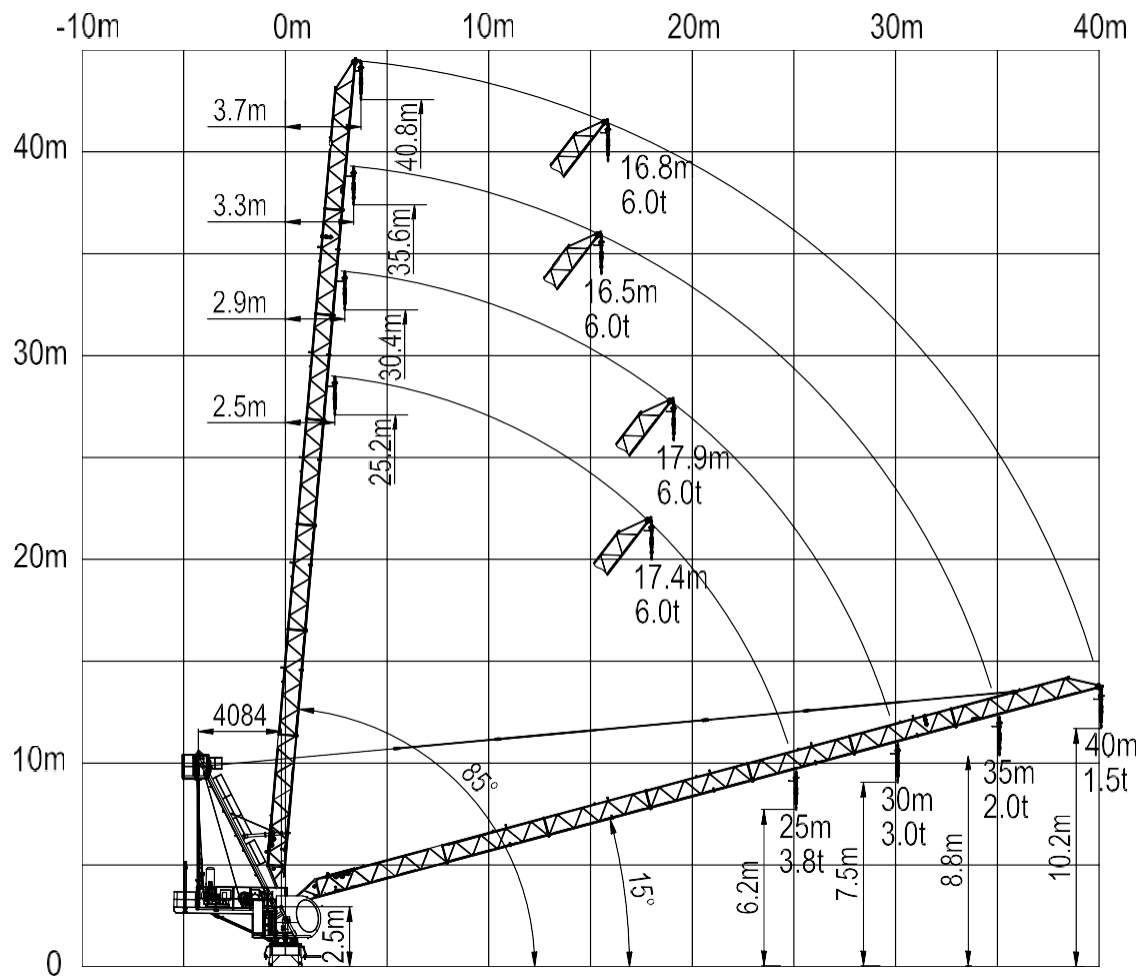

Hoisting 24 kW					Luffing 24 kW	Slewing 95 Nm	Traveling 2x3.4k W
P _{max}		3 - 6.0 [t]					
3b	Load [to]	1.5	2.2	3.0	t=2.0 min	0.80 rpm	22 m/min
	V [m/min]	80	60	40			
3b	Load [to]	3.0	4.4	6.0	Power requirement (upper part)	Power requirement 35.3 KVA	
	V [m/min]	40.0	30.0	20.0			

2.1.2 Jib lengths, Load diagrams, Speeds

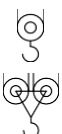

		3.6	16.8	20	25	27.4	30	35	40	m
			3.00	3.00	3.00	3.00	3.00	2.60	1.97	1.50
		3.2	16.5	20	25	27.4	30	35		m
			3.00	3.00	3.00	3.00	3.00	2.60	2.00	
		2.8	10	17.9	20	25	30			m
			3.00	3.00	3.00	3.00	3.00			
		2.4	10	17.4	20	25				m
			3.00	3.00	3.00	3.00				
			6.00	6.00	5.07	3.80				t

2.1.3 Tower configuration, Hook heights, Erection sequence

2.1.3.1 Mast Composition

2.1.3.1.1 Free Standing Cranes

- The mast composition on pages 2.1.3.1.3 are given for free standing heights **IN SERVICE** and **OUT OF SERVICE** and for the static and rail-mounted versions indicated in the data sheet "TELE-SCOPIC".

The assembling order is that given in paragraph 2.1.3.1.3 for reasons of strength. These documents deal with the optimum composition of the crane tower which is not allowed to be lower. But it is possible to fit stronger sections (*).

-Unusual Cases

-With rigid anchorages to the building

-The mast compositions and the loads applied on the frames are given in the chapter 2.1.3.1.3 specific to this operation.

-With anchorage by guy ropes Please consult us.

-With climbing inside the building

-The mast compositions and the loads applied on the frames are given in the chapter 2.1.3.1.3 specific to this operation.

(*) Please consult us.

-Reducing the free standing height due to the telescopic cage. If, for reasons of later increase in height, the telescopic cage is to be left at the top of the masts, it is absolutely necessary to reduce the free standing height

"IN SERVICE" and "OUT OF SERVICE" by removing x mast sections (**). (**)
Compulsorily consult us

IMPORTANT: The very high cranes are subjected to a downgrading of the load, see chapter

"Special Characteristics".

2.1.3.1.2 A set of recommended mast sections

SR24E (Φ50-Φ40) Sections of 10.5m length

Cross section 1.2 x 1.2 m – length 10.5 m – Upright L 160x16 – Monoblock mast section – with jacking steps

- Lower fish joint D50 – upper fish joint D40. **S24C1 Sections of 3m length**

Cross section 1.2 x 1.2 m – length 3 m – Upright L 160x16 – Mast section made up of panels– with jacking steps.

2.1.3.1.3 Mast composition and stresses for climbing crane

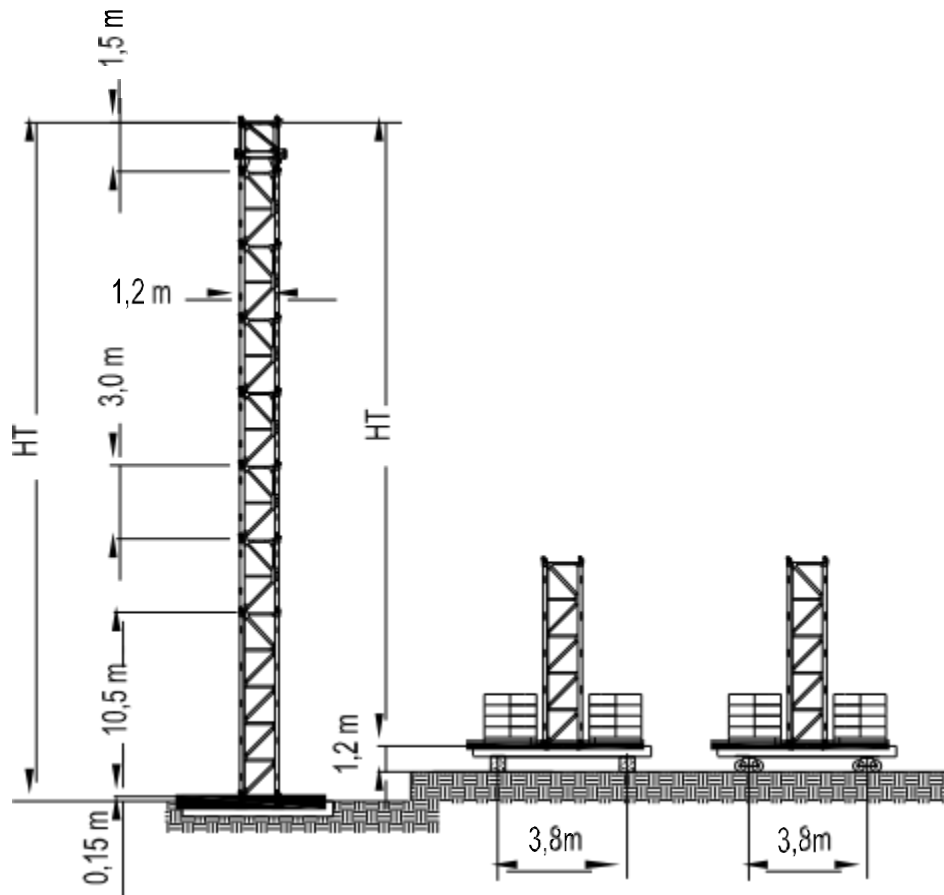

HT height	Mast composition		
	Mast sections		
	SR24E (Base mast)	S24C1 (Mast)	Telescoping Mast
15.1	1	1	1
18.1	1	2	1
21.1	1	3	1
24.1	1	4	1
27.1	1	5	1
30.1	1	6	1

2.1.3.4 MAST COMPOSITION (HIGH CRANE)

MAST COMPOSITION (VERY HIGH CRANE) AND REACTIONS ON THE ANCHORAGES

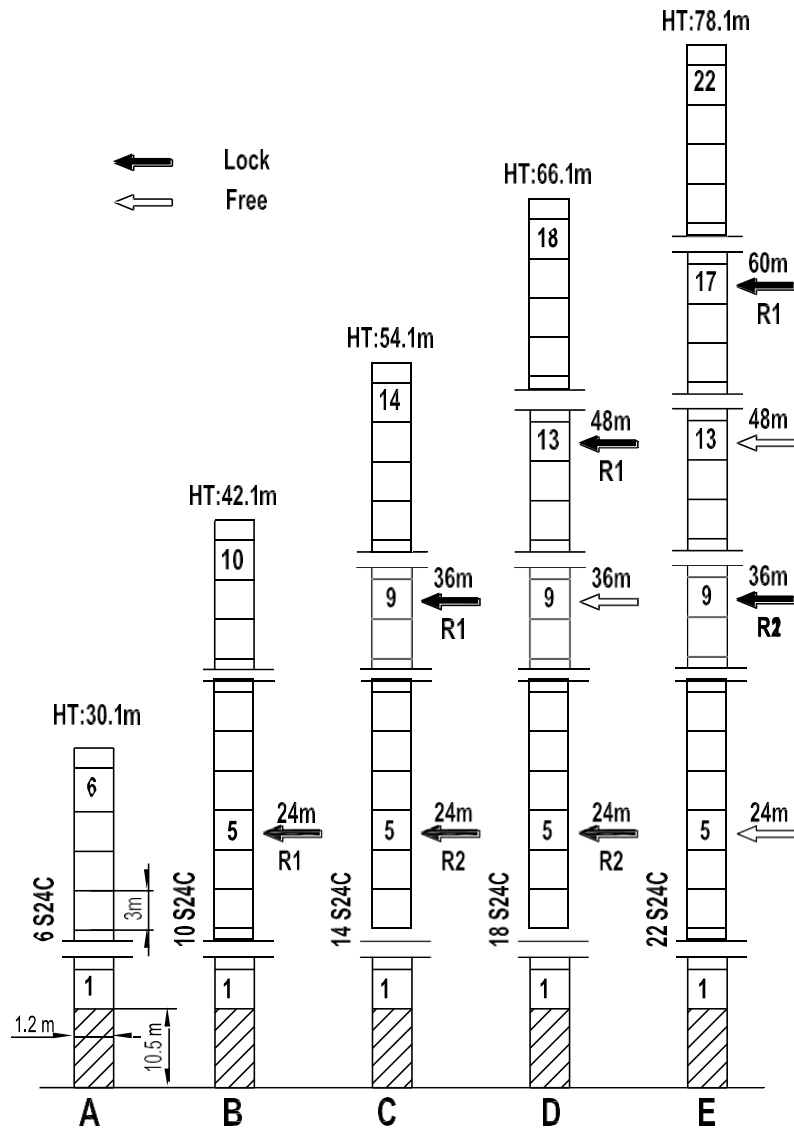

IN SERVICE		OUT OF SERVICE	
R1(kN)	-73.5	R1(kN)	-144.1
R2(kN)	69.1	R2(kN)	52.8

2.1.3.1.5 MAST COMPOSITION (CLIMBING)

- D:** DISTANCE BETWEEN COLLARS
- P:** WEIGHT
- R1:** STRESS IN THE UPPER COLLAR
- R2:** STRESS IN THE LOWER COLLAR

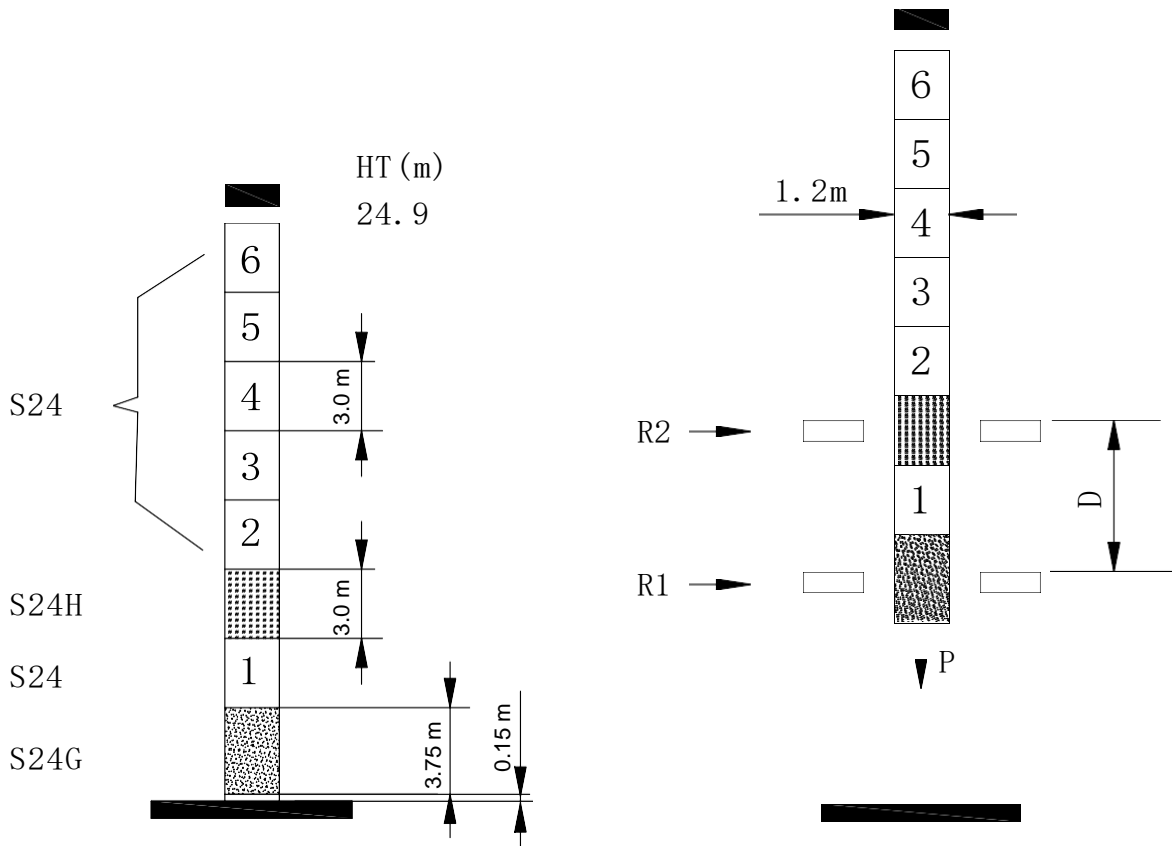

STRESSES FOR CLIMBING CRANE (Cont't)

I In Service				II Out of Service		
Rear Wind/Jib						
D m	P KN	R1 KN	R2 KN	P KN	R1 KN	R2 KN
9.0	314.80	80.55	72.31	299.80	117.25	72.07
10.0		72.35	64.29		103.96	59.76
11.0		65.62	57.77		93.04	49.82
12.0		60.01	52.32		83.89	41.65

2.1.4 Jib and tie bar configuration

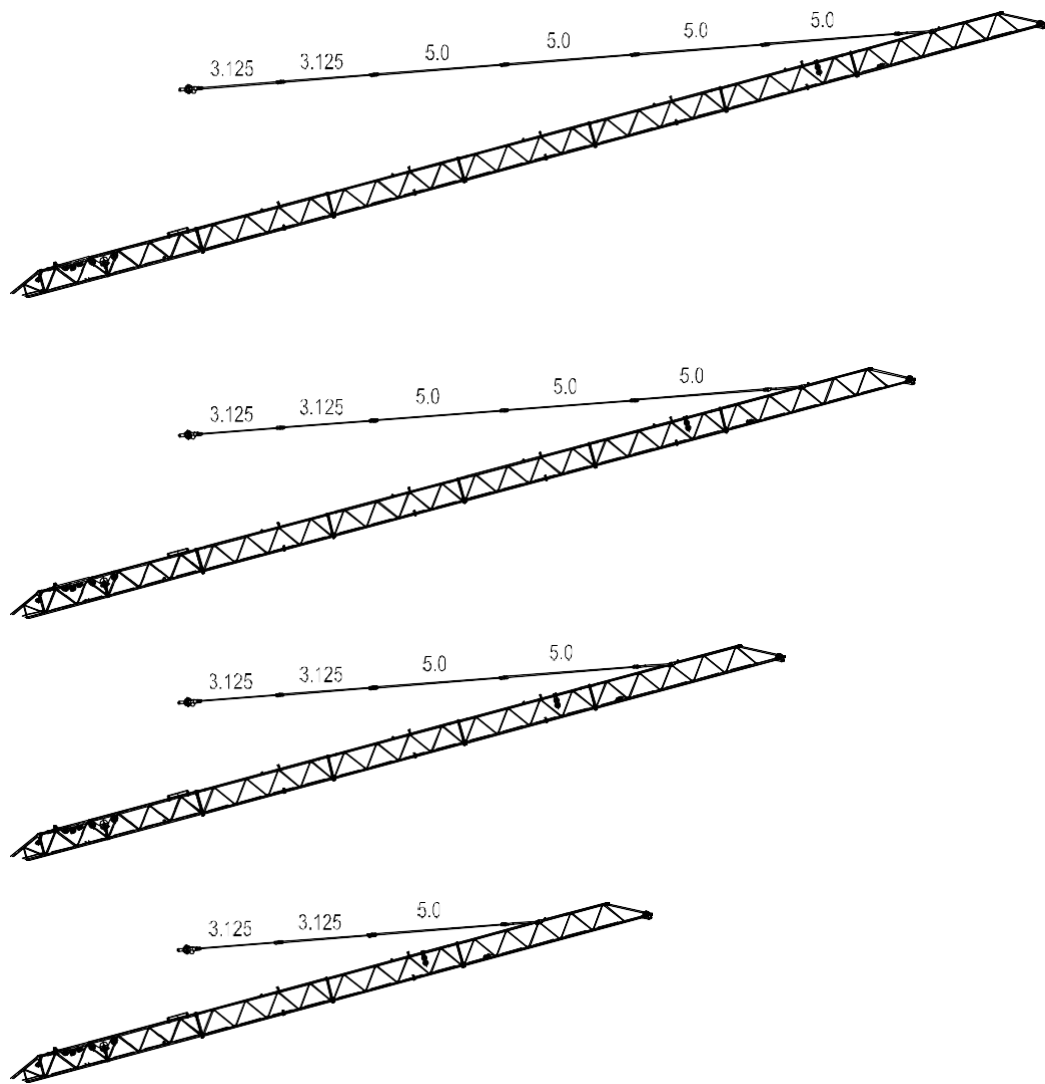

Lengths of jib sections

Jib 01	8.42m
Jib 02	5m
Jib 03	5m
Jib 04	5m
Jib 05	5m
Jib 06	7.5m

2.1.5 Installation of the rope support wheel

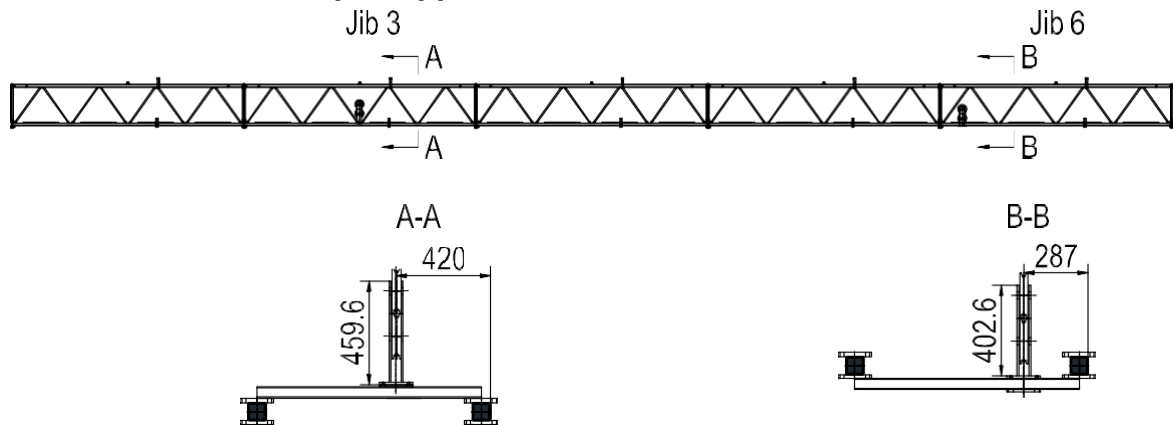

2.1.6 Counter jib ballast

Counter weight

Length of jib (m)	25	30	35	40	
Type	2.0t	5	5	6	6
Weight (t)	10.0	10.0	12.0	12.0	

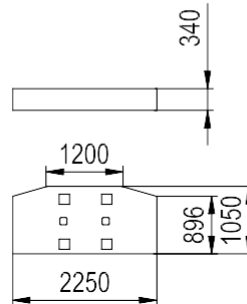

2.1.7 Ropes dimensions and constructions Hoist rope *

Rated diameter:	12 mm
Code No:	35Wx7-1960-12
Standard:	Q/320201PE004-2005
Surface of wires:	bright (NAT)
Rated strength of wires:	1960 MPa
Minimum breaking load:	101.6 kN
Type of lay and its direction:	cross lay, right-handed (ZS)
Luffing rope *	
Rated diameter:	14mm
Code No:	6x29Fi+IWR-1870-14
Standard:	Q/320201PE004-2005
Surface of wires:	bright (NAT)
Rated strength of wires:	1870 MPa
Minimum breaking load:	130.5 kN
Type of lay and its direction:	cross lay, right-handed (ZS)

Lengths in m

Jib length	25	30	35	40	Drum capacity
Hoist rope ²	60	65	70	75	450
Luffing rope	160	160	160	160	160











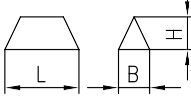

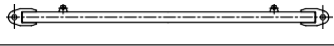

* contact manufacturer if using other makers

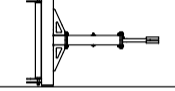
²- for determination of total length of hoist rope add to dead length:

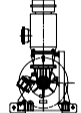
2-fall rope - add 2 times of hook height

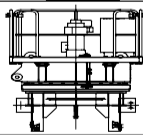
4-fall rope - add 4 times of hook height

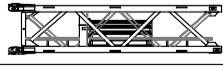
2.1.8 Packing list

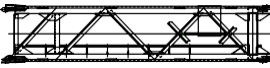
Part	Piece	Description	Diagram		L (m)	B (m)	H (m)	Weight* (t)
			L	B				
UPPORT PART	1	Jib section 01			8.52	1.12	1.11	0.73
	5	Jib section 02			5.24	1.12	1.07	0.39
	1	Jib section 03			7.52	1.12	1.10	0.48
	1	Tower top			8.7	0.90	0.56	1.12
	2	Cradle of tower top			7.03	0.4	0.19	0.13
	2	Support bar of Counter jib			3.28	0.14	0.23	0.15
	1	Damp bar			1.79	1.20	0.22	0.15
	1	Counter jib			5.08	1.16	0.54	1.56
	1	Hoist winch + rope			1.02	1.21	1.68	1.22
	1	Tripod			1.14	1.129	1.62	0.44
	1	Luffing winch + rope			1.51	1.49	1.93	1.41
	1	Slewing table + Slewing support			2.22	2.22	2.12	4.99
	1	Hook block			0.73	0.25	1.35	0.20
TOWER	11	S24 mast			3.25	1.2	1.2	890
	1	S24H section			3.25	1.2	1.2	1050
	1	S24G Base section			3.99	1.2	1.2	1300

*Weight per piece

2.2 Foundation loadings

2.2.1 Foundation loadings

HT height m	No. Of tower	Foundation loading			Foundation plate			Total weight	P Ground
		N _c KN	M _c KNm	H KN	L m	h m	N _F KN	N _c + N _F KN	P KN/M ²
15.1	1	261.1	378.4	36.6	4.45	1.35	642	903	77
21.1	3	278.9	648.4	41.6	4.45	1.35	642	921	94
27.1	5	296.7	960.2	46.6	5	1.35	810	1107	94
30.1	6	305.6	1131.7	49.1	5.6	1.35	1016	1322	83

These Loading are valid for free slewing crane out of service

Slewing Moment $M_s = 80\text{KNm}$ (for jib lengths 25--30)
 Slewing Moment $M_s = 127\text{KNm}$ (for jib lengths 35--40)

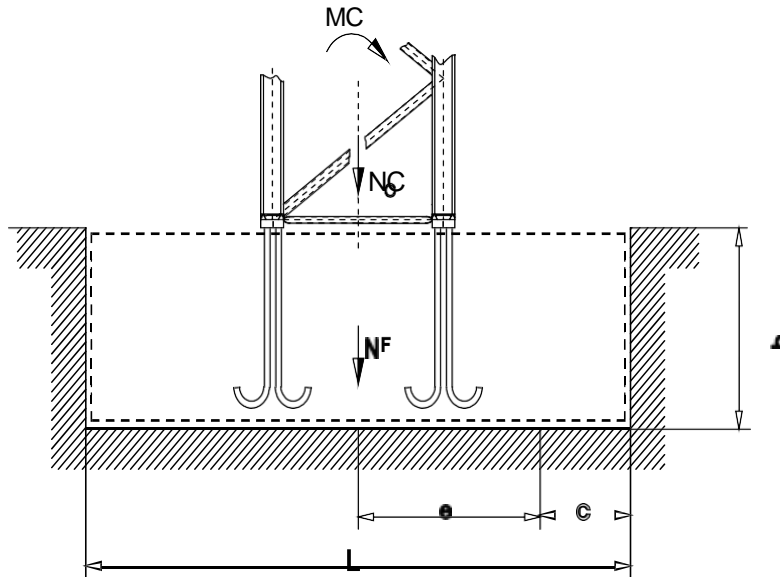

Calculation of the foundation plate

$$N_T = N_C + N_F$$

$$M_T = M_C + H * h$$

$$N_F = L^2 * h * 24$$

First condition : Excentricity

$$e = M_T / N_T < L/3 \quad c = L/2 - e$$



Second condition:Ground pressure $p = 2 * N_T / 3 * L * c$

The admited ground pressure must be checked by the customer.

2.2.2 Preparation of foundation plate

2.2.2.1 Installation on fixing angles

The following tables define

- The loads and the reaction applied on the fixing angles in service and out of service.
- The calculation of the concrete blocks.
- The choice of the concrete blocks and the pressure under the concrete blocks.

There is one table for each type of installation as described in the DATA SHEETS.

The dimensions of the fixing angles, the setting of the fixing angles in the concrete blocks as well as the execution plans are shown in a brochure corresponding to this type of installation.

□ CONDITION OF EXECUTION

-BY THE CUSTOMER

The table of reactions and loads, the dimensions of the fixing angles and the setting of the fixing angles in the concrete block are necessary and sufficient in order to determine a concrete block (Dimensions and reinforcement).

The indicated reactions and loads do not include coefficients for dead weights or dynamic coefficient for the lifting load.

It is appropriate to take into consideration the usual or standardized safety coefficients valid for the indicated loads and reactions. If not, it is advised to apply at least a safety coefficient of 1.5.

IMPORTANT: FOR THE REQUIREMENTS REGARDING THE GROUND STABILITY OF THE CRANE MINIMUM DIMENSIONS ON THE GROUND ARE PRESCRIBED AS WELL AS A MINIMUM MASS WHICH ARE EQUAL TO THOSE OF THE SMALLEST PERMISSIBLE CONCRETE BLOCK (Pressure under the concrete blocks”)

FOR ANY OTHER DIMENSIONS WHICH DO NOT OBSERVE THESE RECOMMENDATIONS PLEASE CONSULT US.

-According to the prescription of GH: in compliance with French Standards

If not usable abroad, prepare the concrete block according to the paragraph or consult us.

-Choosing procedure

The permissible ground pressure of the site determines the optimum type of concrete block to be used for the final height to be obtained and for the each type of installation and crane. For all cases of height, choose the concrete block which has a ground pressure less than or equal to the ground pressure of the site .

-Execution of the concrete blocks

The plan described in chapter 18A is in compliance with the maximum loads given for each case.

2.2.2.2 Substructure on fixing angles

·General notes

There is only one type of fixing angles:

- Not reusable fixing angles; They are set into the concrete block

The choice of the concrete block and the loads and reaction applied on the fixing angles are given in the brochure

·Fitting the fixing angles

A bad mounting of the fixing angles may cause serious troubles when using the crane (Perpendicularity not observed, warpage of the fitting surfaces of the mast)

An operating method is given as indication in paragraph 18A-0420 for not reusable fixing angles. The fitting elements (frame, standard mast section) recommended in the operating method can be supplied at the same time as the fixing angles and before the crane.

NOTE: The frame is only used for fitting the fixing angles

·Execution of the concrete blocks

The plans described on the following pages are in compliance with the maximum loads given for each case

IMPORTANT: THE REINFORCEMENT IS GIVEN ON THE FOLLOWING PAGES AS AN INDICATION AND CAN BE CARRIED OUT DIFFERENTLY, IF NECESSARY, UNDER THE RESPONSIBILITY OF A COMPETENT SPECIALIST

2.2.2.2.1 Installing the not reusable fixing angles

·Fitting the not reusable fixing angles

Dimensions of the fixing angles

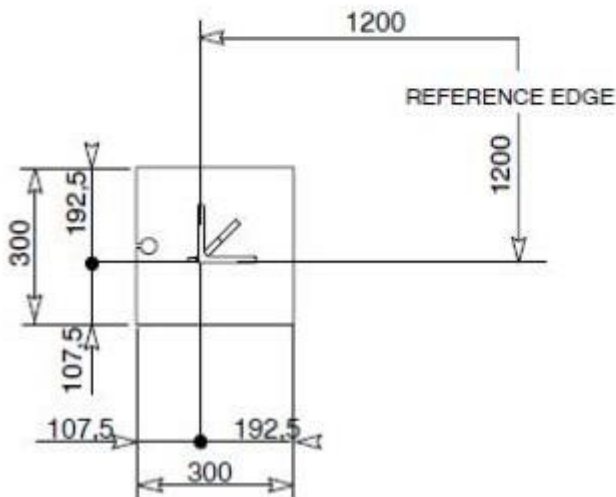
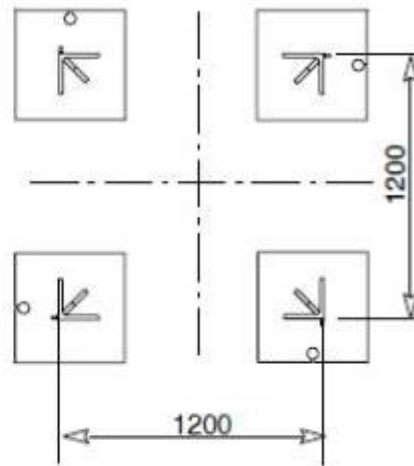
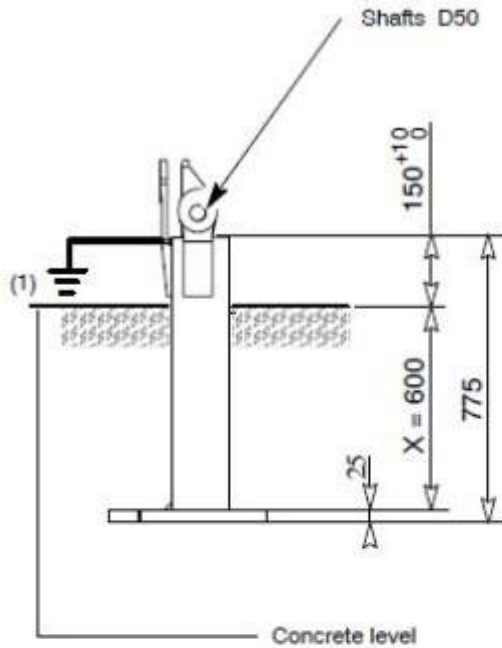

SETTING INTO CONCRETE OF THE FIXING ANGLES

In order to set perfectly into concrete the fixing angles, following components are necessary:

- 4 fixing angles and 8 shafts
- 1 template
- 1 sighting device

The fixing angles and the template can be supplied before the delivery of the crane.

The fixing angles must be symmetrically set into concrete with regard to the axes of the concrete block and form a square according to the dimension of the masts to be fitted.

Tolerance of surface evenness: $1/400$ of the mast cross-section

Near the fixing angle, never cut reinforcing steels nor reduce their number given.

Take care that the fixing angles are correctly earthed (see Operating Instructions)

The template is only used for fitting the fixing angles

IMPORTANT: WHEN ASSEMBLING THE FIXING ANGLES AND THE TEMPLATE, MAKE SURE THAT BEARING SURFACES OF BORINGS AND SHAFTS ARE CLEAN AND FREE FROM ANY SMEAR

- Outside or inside the ditch, arrange the fixing angles (1) by observing their distance (Detail A - Figure 1).
- Pin-connect the template (2) to the fixing angles (1) by means of 4 x 2 shafts (3).
- Lock the shafts (3) using the pins (4); fix the pins with split pins (Detail B, C - Figure 1).

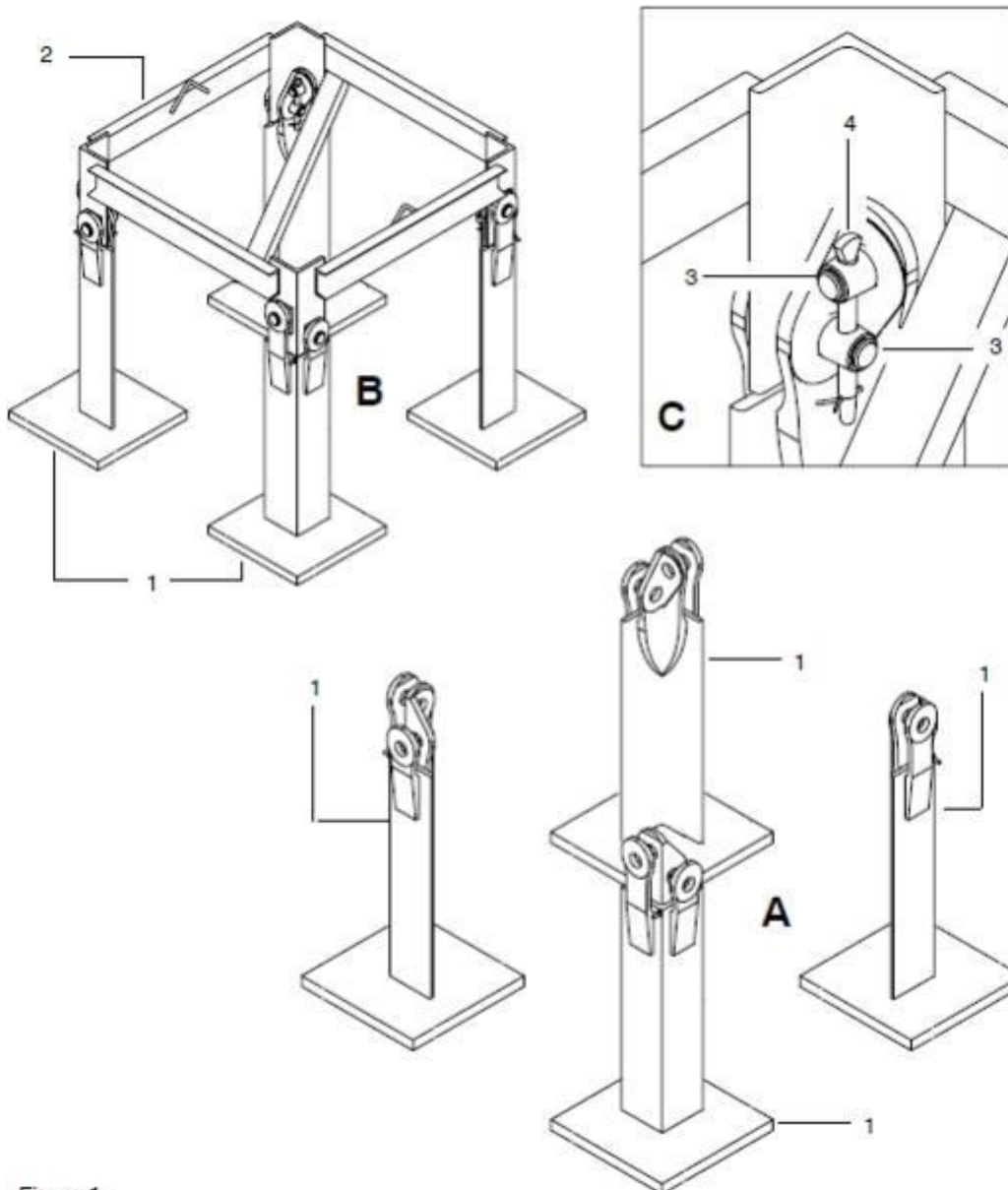

Figure 1.

- Position the assembly comprising the fixing angles and the template in the reinforcing steels arranged-in the ditch and carry out an adjustable wedging (1) under the plates of the fixing angles (Detail A -Figure 2).

IT IS ESSENTIAL TO OBSERVE THE DIMENSION OF 150 mm (Detail B - Figure 2);

-Check the surface evenness of the fixing angles by means of the sighting device.

The sighting reference is to be taken at the top (a) of the template uprights (2) (Detail C - Figure 2).

-Pour the concrete block and wait until it is completely dry, before dismantling the template.

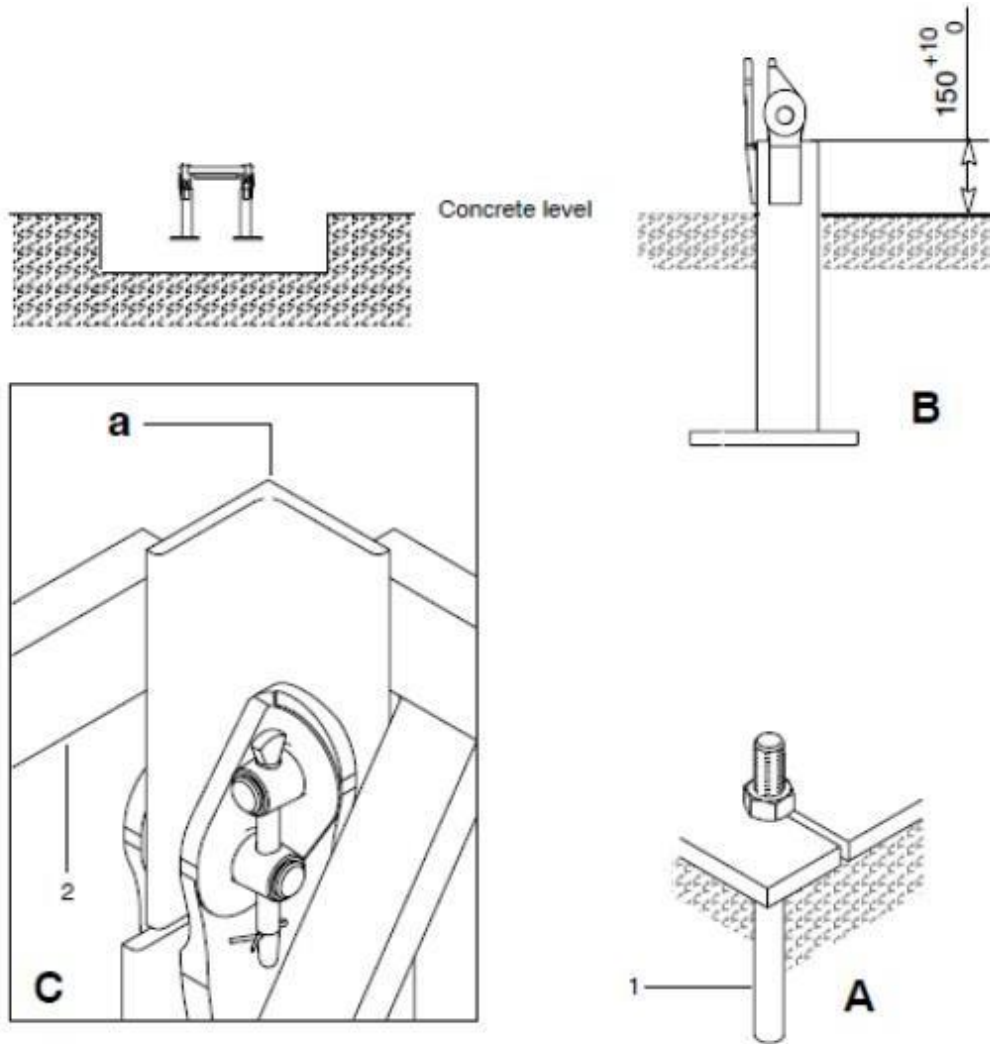
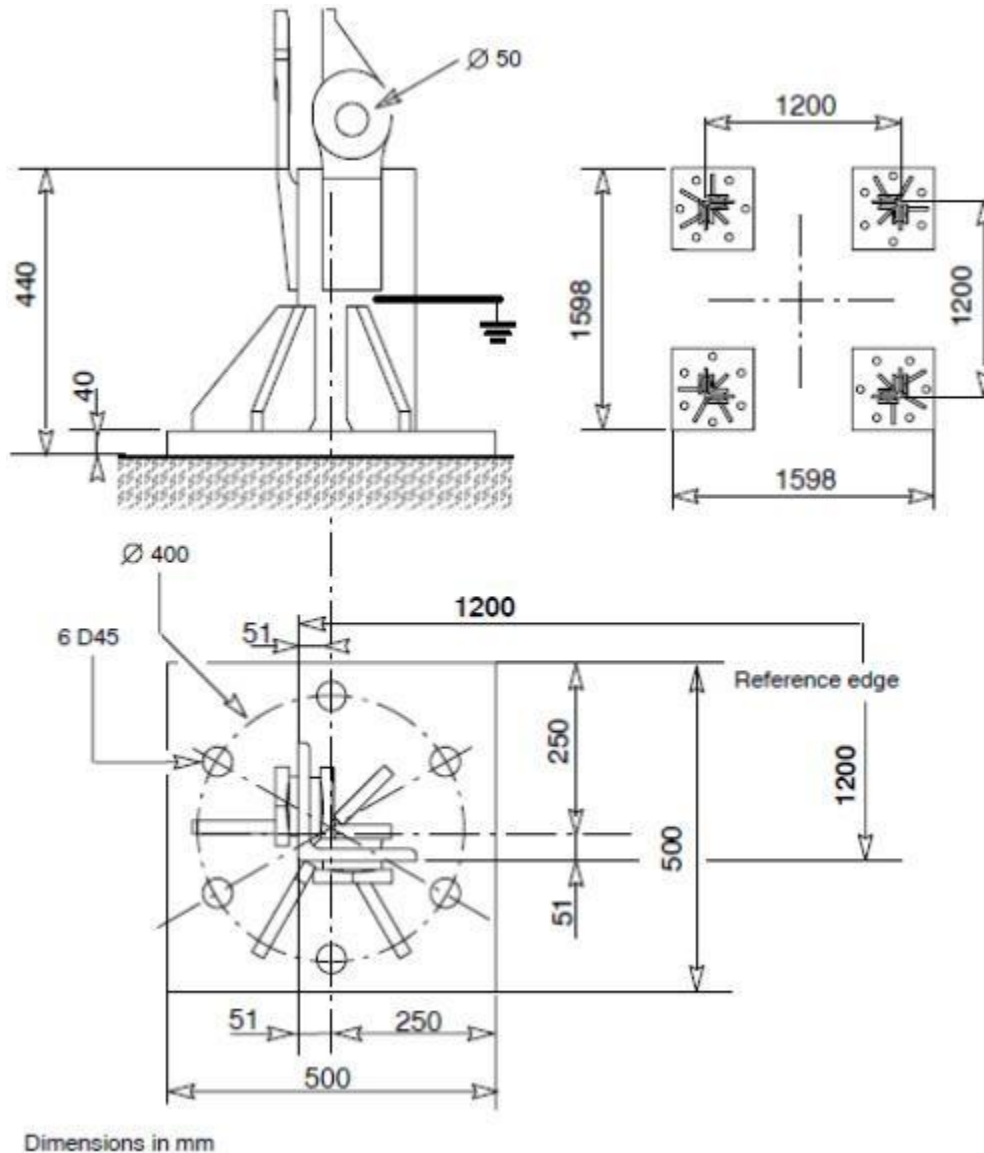

Figure 2.

2.2.2.2 Installing the reusable fixing angles

Dimensional characteristics of the fixing angles



Installing the fixing angles

-The dimension, number and fitting of the fixing rods of the fixing angles onto the concrete block (or any other structure) are on the user's responsibility. The loads and reactions are given in chapter 006.

-It is possible to use the constructor's standard of concrete blocks for the information of mass, dimensions and ground pressure. The concrete blocks are defined for the plate-type fixing angles. Therefore, it is compulsory to adapt them to the reusable fixing angles and to the connecting method between the fixing angles and the concrete block. The adaptation of the reusable fixing angles to these concrete blocks is on the user's responsibility (the reinforcement type is to be adapted to the fixing rods used).

-Near the fixing angle, never cut reinforcing steels nor reduce their number given.

-The fixing angles can be supplied before the delivery of the crane in order to use them as positioning jig for the fixing rods of the fixing angles. The template can also be

supplied before the delivery of the crane.

- The template is only used for fitting the fixing angles.
- Fitting this equipment increases the hook height by 290 mm in comparison with the standard fixing angles to be set in concrete.
- Take care that the fixing angles are correctly earthed

Determination of a fixing

-The tables of the chapter 009 give the tensile load, compression and shearing forces applied on the fixing angles for the various working heights. These information allow carrying out the calculation of the fitting of the fixing angles are adapted to your case of use, knowing that the shearing force is always taken up by two fixing angles.

-In general, it can be indicated that, in case of fixing by screw connections or by high-strength tie rod, class 10-9 (elastic limit of 90 kg/mm²), a correct assembling will be obtained by observing the following data, that is to say:

F – maximum static load under tensile strength on 1 fixing angle.

Fe – the capacity corresponding to the elastic limit of the tie rod.

-Definition of the number of rods (N) to be used per fixing angle.

$$F/0.3Fe=N \text{ (to be rounded)}$$

-The number of the rods is always even: 4 or 6, and symmetrical with respect to the upright.

Note: Considering a permissible load per rod, equal to 0,3 of the elastic limit, taking up the moment given by the shearing force and the various dynamic coefficients are integrated.

-Prestress Fp to be applied on the high-strength rod (Fp = 0.5 Fe)

Important: Besides these information concerning the number and the quality of the rods, choosing and fitting workmanlike the fixings are entirely on the user's responsibility.

Installing the rods

-Fitting the rods varies depending on the number of rods used:

-4 rods – use the holes 1, 3, 4, 6 (Figure 1)

-6 rods – use the holes 1, 2, 3, 4, 5, 6 (Figure 1)

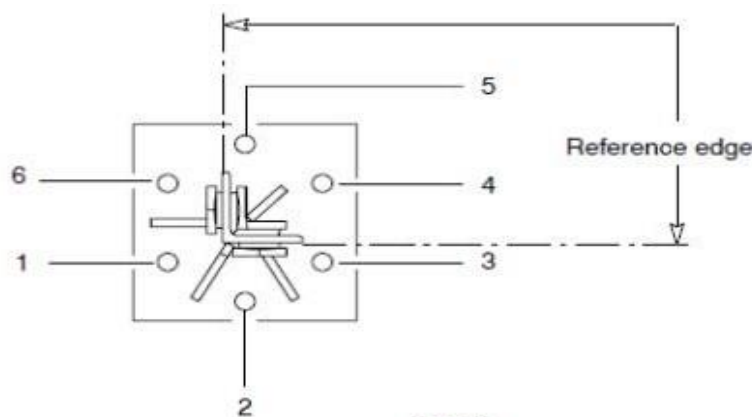

Figure 1

Installing the fixing angles

- Arrange the fixing angles (1) by observing their distance (Detail A – Figure 2).
- Pin-connect the template (2) to the fixing angles (1) by means of 4 x 2 shafts (3).
- Lock the shafts (3) using the pins (4); fix the pins with split pins (Detail B, C – Figure 2).
- Tighten the nuts of the fixing rods according to the supplier's instructions.
- Check the surface evenness of the fixing angles by means of the sighting device. The sighting reference is to be taken at the top (a) of the template uprights (2) (Detail C – Figure 2).
- Tolerance of surface evenness: 1/400 of the mast cross-section

Important: When assembling the fixing angles and the template, make sure that the bearing surfaces of borings and shafts are clean and free from any smear.

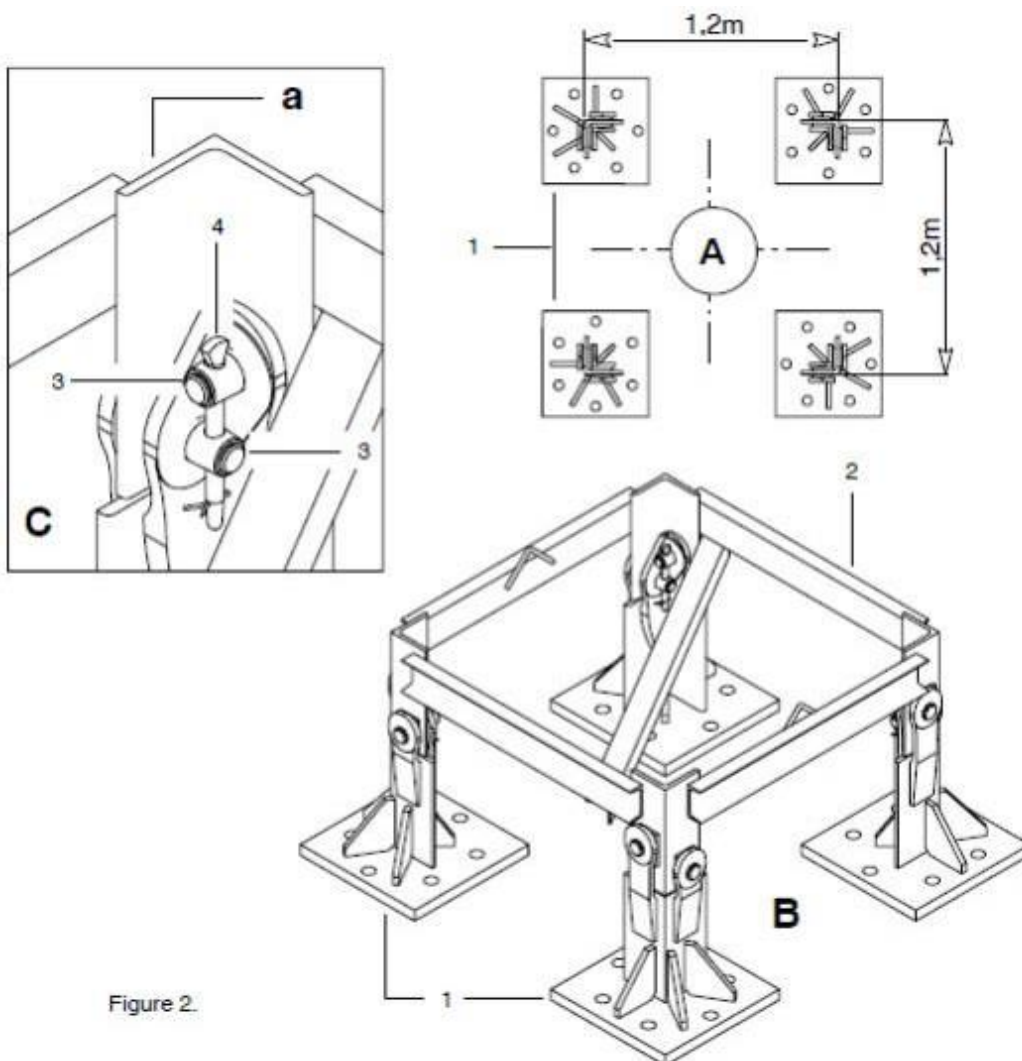

Figure 2.

2.2.2.3 Preparing the concrete blocks

-Fabrication rules for reinforced concrete

Concrete and reinforcement determined according to the BAEL (reinforced concrete boundary condition) Rules, 1983

-Concrete

- f_{tj} = characteristic tensile strength of the j days old concrete
- f_{cj} = characteristic compressive strength of the j days old concrete

NOTE1- In any case, the compressive strength is measured by axial pressure of the cylinder having a periphery of 200 cm² cross section and a height which is the double of its diameter (16 cm) These dimensions suppose an aggregate size of at least equal to 40 mm, a condition generally fulfilled for reinforced concrete

NOTE2- The dimensions and characteristics of the reinforcements and of the concrete for the execution of concrete works indicated in this manual, are defined by a compressive strength value at 28 days old ($j=28$)

Reinforced concrete mixing of 350kg/m³ -CPA45 that means, for 1m³ of sand with gravel : 350kg PORTLAND cement 45

For a vibrated concrete correctly prepared, we obtain:

$F_{c28} = 20\text{Mpa}$

$F_{t28} = 0.6 + 0.06f_{c28} = 1.8\text{ Mpa}$

P = weight of reinforced concrete in daN

D = average density of reinforced concrete equal to about 2.35

-Steel (except other indications)

E_s : Longitudinal modulus of elasticity of steel: 200000 N/mm²

Type 1: Reinforcement with high adherence obtained by hot- rolling of natural high-carbon steel

Should the above rules not apply, refer to the rules applied in the user country

-Explanation and symbols

Designation of a concrete block (M54N)

- M: Concrete block
- 54: weight of the concrete block in tons
- N: internal coding

The reinforcement of a concrete block is composed of an upper and a lower reinforcing cage connected by pins each cage comprises two crossed layers

**Upper layer
(Example)**

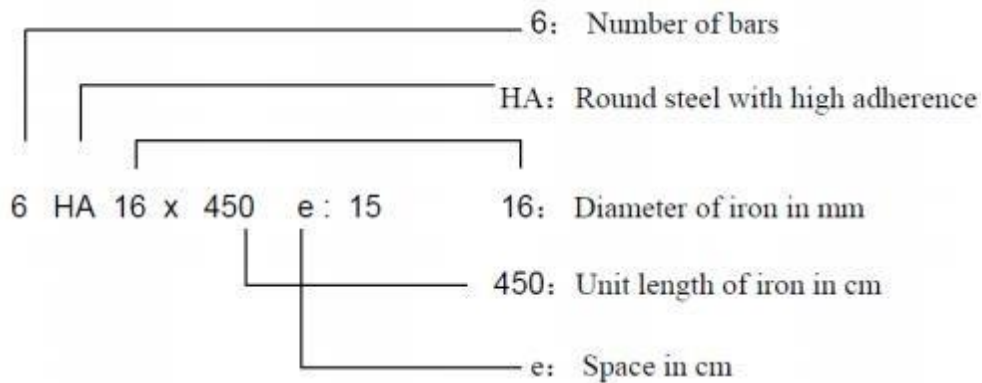

Lower layer

Ep: pin

D: density

V: volume in m³

L: length in cm

l: width in cm

H: height in cm

1LH: First upper layer

1LB: First lower layer

2LH: Second upper layer

2LB: Second lower layer

In both direction

A Foundation (M64N)

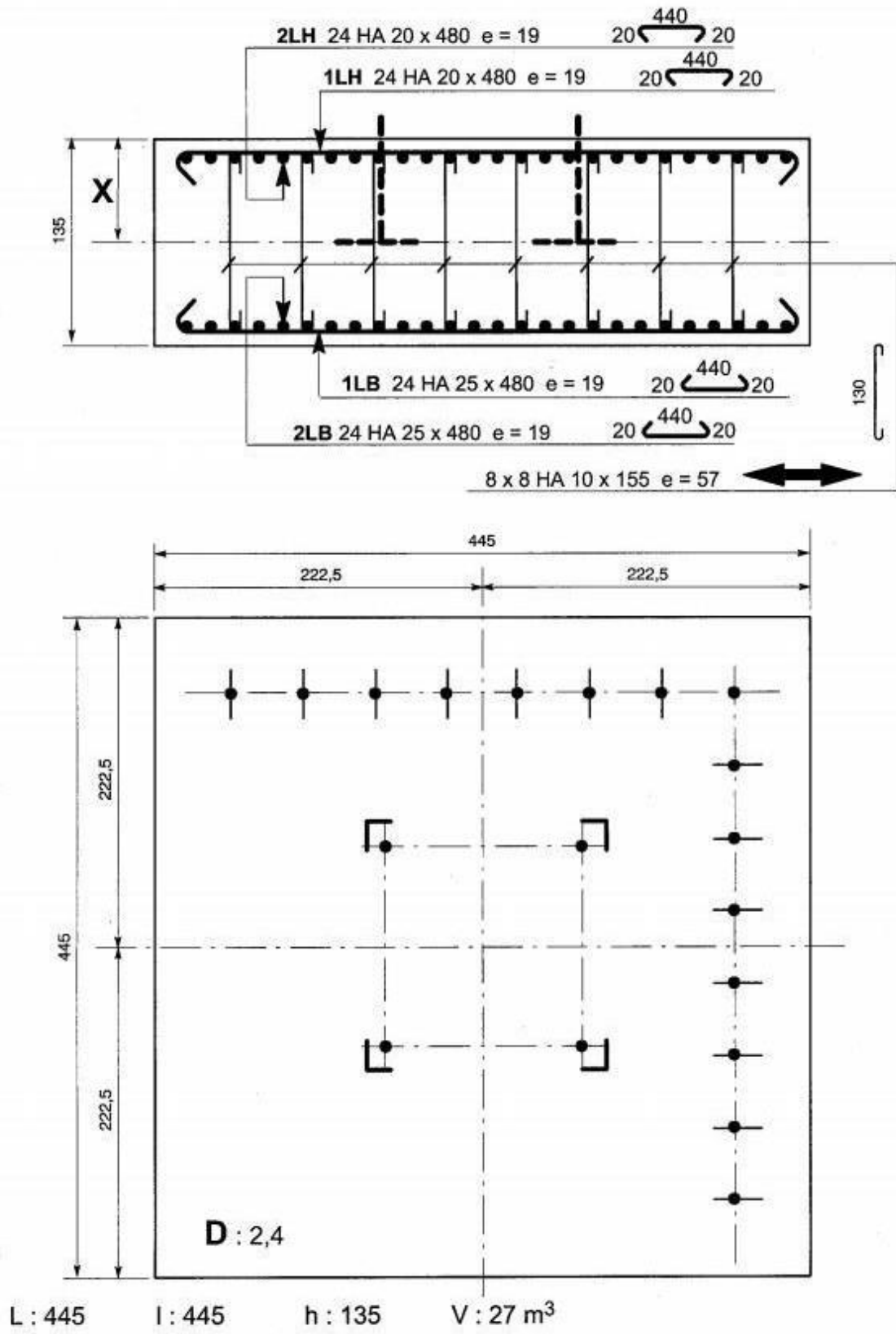

B Foundation (M81N)

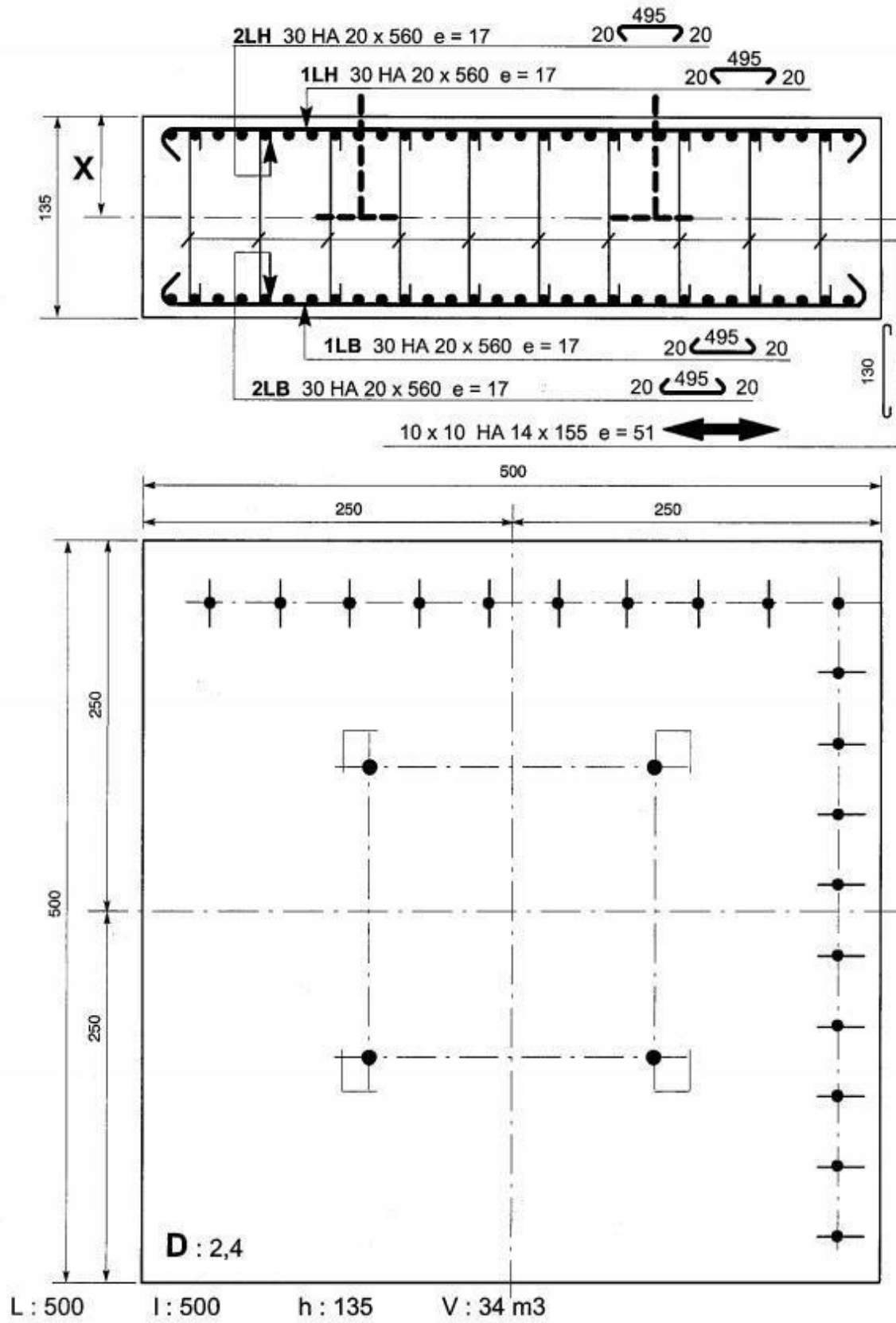

C Foundation (M101N)

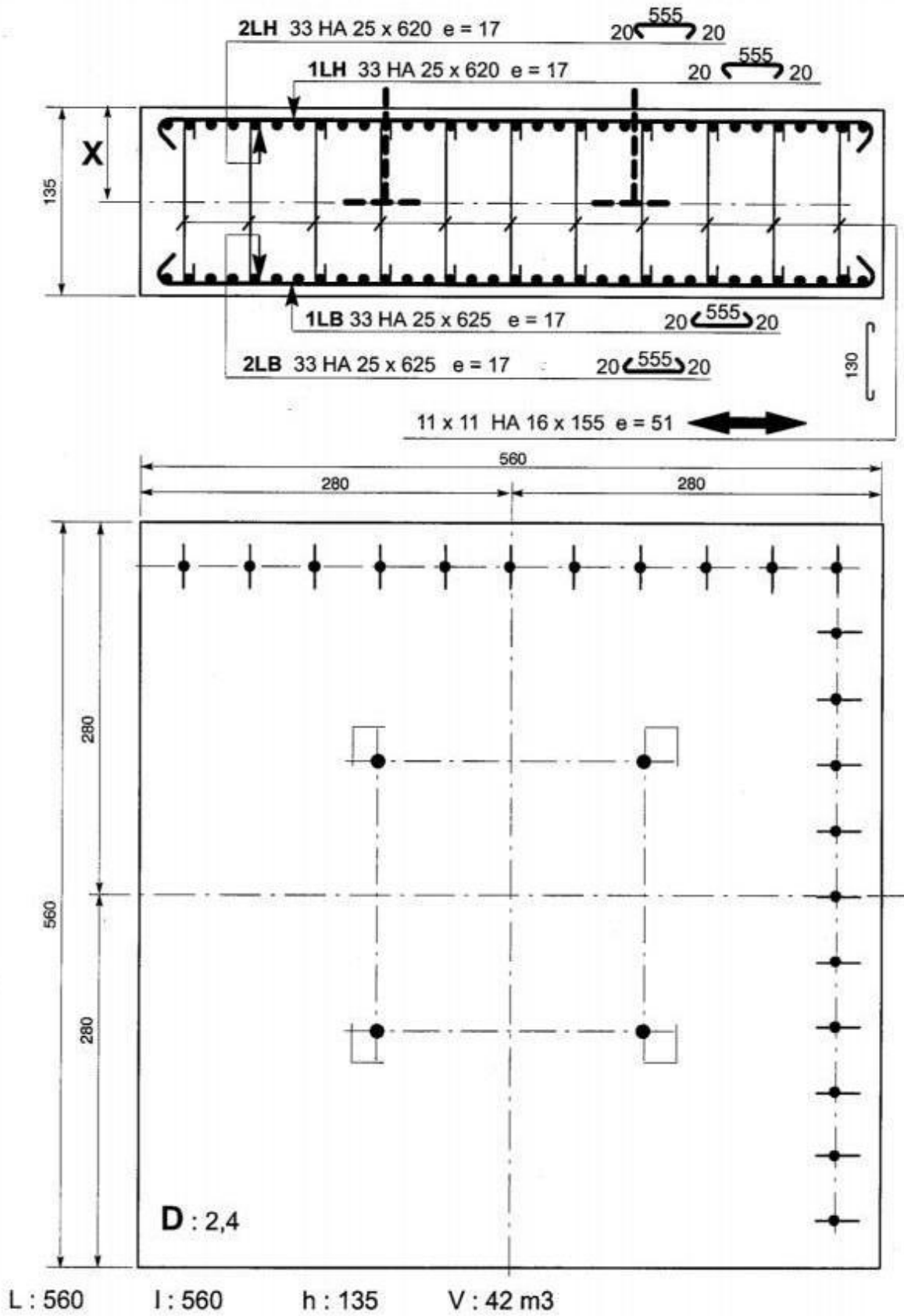

2.2.3 Earthing

The user is responsible for the installation of the protective bonding system and must ensure that the minimum requirements established by the standard are attended.

As for the sizes, installation, test and maintenance of the protective earthing system against atmospheric discharges, the laws and standards of the country, where the crane is assembled are to attend.

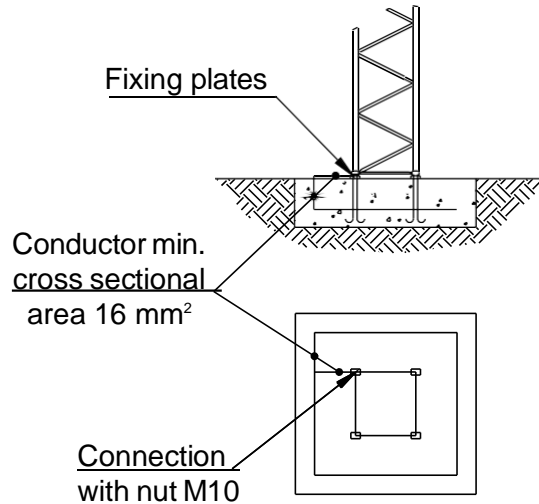

Conductor must be connected on one of the fixing plates.

2.2.4 Electric power supply

The electric equipment of the crane must always be connected to the bonding circuit. The user must provide the necessary electrical supply and wiring/connections for the crane to meet its electric energy needs, adhere to the specifications described herein, and conform to standard electrical codes as well as conform to the norms for electrical installations in the place and country where the crane is being installed.

For the dimensions of the connection see the maximum wire lengths and cross-sections diameters of the conductors according to the electrical load applied.

Results depicted in the table use the following requisites as the basic for making the calculations: symmetrical and balanced three-phase system with 380 V voltage, 50 Hz frequency, 0.8 (cos ϕ) power factor and power cable capable of withstanding a continuous working temperature of 60°C.

For exposed cables or cables routed through underground conduits, it is suggested to use NIVVK fire retardant type cable. For other type of installation, such as using a cable reel, it is advisable to select the most suitable type basing on the sectional area, length, weight and bending radius, if any.

The electrical power source must meet the requirements for the particular crane and likewise comply with the established standards.

CEI EN 60204 standards are applicable to the electrical equipment of the crane: therefore, voltage requirements must be within a 10% maximum tolerance, and the maximum marginal frequency variance for a short period of time is 2% (cf. CEI EN 60204 4.3.1).

The user must ensure that the power source voltage and frequency requirements meet the specifications and standards necessary to operate the crane. Remember that the frequency requirement is particularly important should generating sets be used for feeding the crane.

Manufacture's technical department is at customers' disposal for any needed assistance, clarifications, or for providing service for any special need that could arise at the building yard.

Adequate overload protection for the mains must be provided depending on the electrical requirements of the crane. Fuses used for line protection must be "aM" type. If thermal or differential cut-out circuit breakers are used to protect the line input, the electrical protection curve of these protection devices must be like that of starting squirrel-cage motors (D curve).

The connection between crane and the earth bounding circuit must be completed before the crane is connected to the main power supply.

2.2.5 Out of service

Jib length (m)	25	30	35	40
Distance D	20~ 25	25~ 30	30~ 35	35~ 40
Jib angled°	15°~ 30°	15°~ 30°	15°~ 30°	15°~ 30°



General instructions for assembly	Chapter 3
3 Preparation of the building yard.....	52
3.1 Introduction	52
3.2 Ground consistency.....	52
3.3 Crane installation area	52
3.4 More cranes on the site.....	52
3.5 Inspection of the building yard.....	53
3.6 General instruction for crane operator and assembly team	54
3.7 Unallowed crane moves	56
3.8 Assembly and disassembly advices	56

3. Preparation of the building yard

3.1 Introduction

The responsibility for the preparation of the crane building yard rests entirely with the crane user. Any clearing, leveling, building up or reinforcing of the ground where the crane will be positioned and operated will be carried out by him as well as the verification of feasibility of the different crane installation proposed by the manufacturer.

3.2 Ground consistency

The primary requirements to be met on the building yard before the arrival of the crane are the installation of the base platform or travelling rails, depending on the configuration chosen.

The installation of such elements depends particularly on the type of ground and foundation on which these assemblies are to be placed, as well as on the configuration characteristics of the crane.

The Buyer therefore must carry out a careful inspection and analysis of the ground consistency on which the crane is to stand.

3.3 Crane installation area

When choosing the location for the crane at the building yard, the Client must be particularly careful to ensure that the crane is not obstructed during its operational movements. Likewise he has to verify that, when the crane is under no-working conditions, its free slewing doesn't allow coming in contact with existing buildings, buildings under construction, stored materials, scaffolding, adjacent cranes, machines, installations, cables, trees, etc.



Nearby electrical lines must be at a minimum safety distance of 5 m from the slewing unit of the crane.

In any case, the local electricity board must be contacted to verify the minimum safety distance recommended from high intensity electrical power cables or transformers.

3.4 More cranes on the site

When two or more cranes are working at close range (inferior to the respective jib lengths sum) in the same building yard can interfere each other. The following precautions must be taken:



Jibs must be offset to avoid collision of any structural parts considering the maximum oscillation amplitude and a reasonable safety distance.



The minimum distance between the two cranes must anyhow be great enough to prevent the cables and loads of the higher crane from interfering with the lower crane.



In case of interfering cranes electrical or radar anti-collision devices can

be installed to limit the crane working range. Always consult the manufacturer for the installation of this safety device, once ascertained it really serves the purpose.

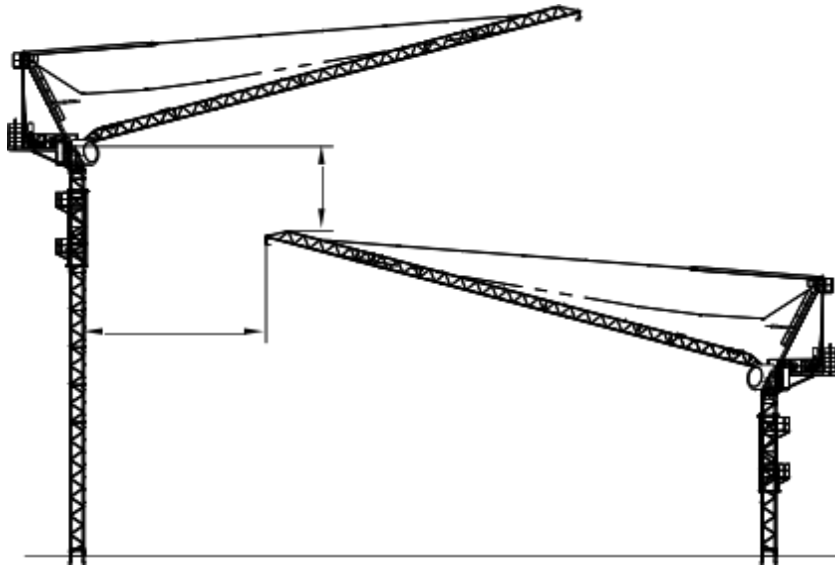

Remember that cranes must be always staggered in height to avoid any interference when under no-working conditions.

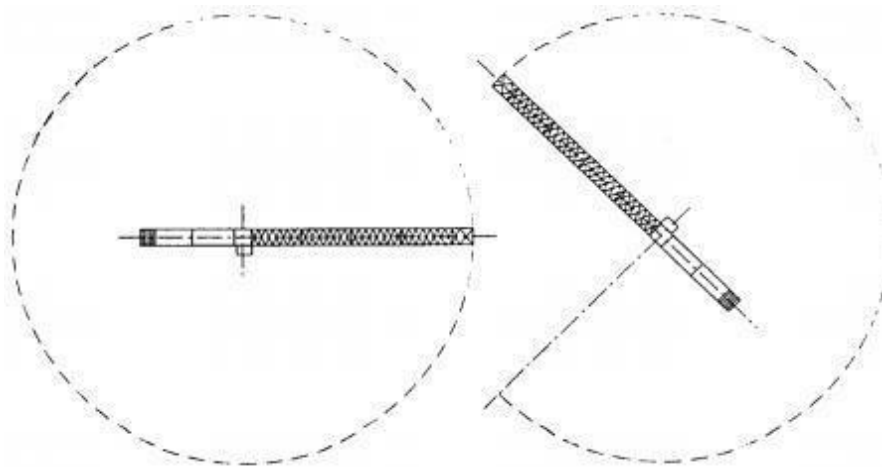

3.5 Inspection of the building yard

Before starting work, the supervisor of the crane assembly is obliged to inspect the building yard and ensure that everything has been properly arranged.

The person in charge of the building yard shall be advised of any insufficiency so that the problem can be resolved.

Assembly of the crane shall proceed only if the building yard conforms to the points listed below.

Before the crane is installed, the supervisor shall check that:

- a) the manouvering area of the crane is free of obstacles (trees, buildings, electric lines, telephone lines, etc.);
- b) the curing time of the foundation plate, base and ballasts is adequate;
- c) the ballast and calibration weights correspond to the required specifications;
- d) The travelling stop buffers are available and assembled when installing a travelling crane;
- e) The electric connections are adequate;
- f) mobile crane suitable for the work to be carried out.
- g) The supervisor shall inspect the slinging devices (ropes, slings, chains), which are to be used for lifting the crane components.



The supervisor must inform the mobile crane operator of the exact weight of the parts that are to be hoisted.

The mobile crane operator is fully responsible for the slinging and hoisting of the loads.

The weights of the crane components see chapter 4 in Assembly – disassembly.

3.6 General instruction for crane operator and assembly team

The crane must be used only by skilled (crane operator with licence).

The operator is authorized to carry out only those operations described herein below attaining to the relative instructions.

As the crane can perform more than one movement at a time, it's upon the operator to control this simultaneousness according to the visibility of the suspended load.

The operator must be able to follow the trajectory of the moving load at any moment.

If not, he must take precautions; in particular, he must be assisted by other people who, with verbal and / or hand signals, provide him with all the information necessary to work in safety.

For a correct use of the crane, the operator must observe the crane maintenance rules and carry out periodical inspections of the whole system as described in chapter 7 - Maintenance.

The use of original spare parts or spare parts however recommended by the

manufacturer plays a prominent part in the correct use of the crane.

Any subsidiary material necessary to the building yard, such as buckets, belts, etc. and belonging to the buyer must be suitable for the correct use of the crane and in conformity with the territorial regulation in force.

- All national and local safety standards must be adhered to.
- May wind speed during the assembly – see chapter 4 – Assembly.

3.7 Unallowed crane moves

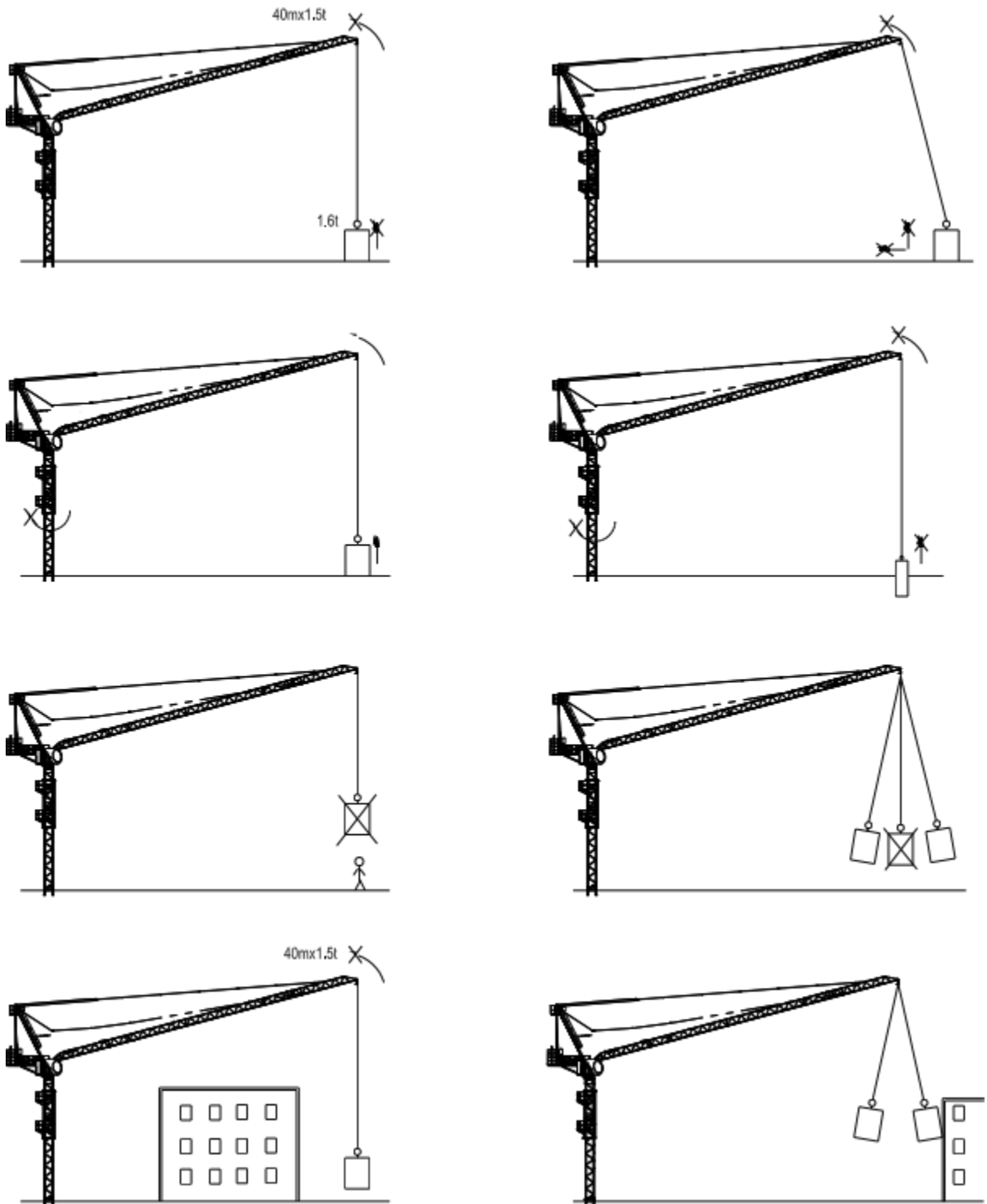

3.8 Assembly and disassembly advices

Assembly and disassembly of the crane must be done by skilled supervisor, who have attended a specific training course.

Crane users are advised to contact (manufacturer or his agents) for qualified supervisor.

Should the user employ other supervisors, their ability should be verified before handling the crane. In this case crane manufacturer declines any criminal and public liability.



For the crane assembly and disassembly at least three skilled technicians are needed: Two in charge of the overhead assembly, one of the co-ordinations of the operations on the ground.

3.8.1 Safety precautions

The supervisor must observe the following safety precautions before starting the assembly or disassembly of the crane:

- a) he must not operate with inclement weather conditions;
- b) he must operate in perfect psychophysical conditions and he must check that the individual and personal accident prevention devices are available and serviceable;
- c) he must wear a safety helmet which is integral;
- d) he must wear an approved safety belt which is in perfect condition;
- e) he must wear accident-prevention shoes;
- f) he must use tools equipped with electric insulation;
- g) should the components pre-assembled on the ground be wet or damp, he must not carry out the overhead assembly of the crane;
- h) for the safety of people and things, the supervisor must be sure that barriers are placed around the assembly and disassembly area and that there are no unauthorized people allowed into the working area.
- i. Hand signals

3.8.2 Supervisor must explain the hand signals to his technicians.

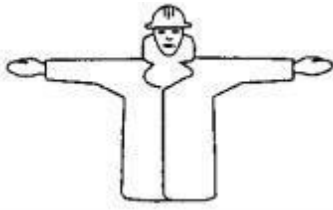

Danger



Horizontal distance



Start

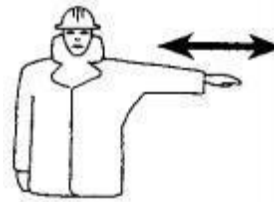

Moving to the Left



Stop

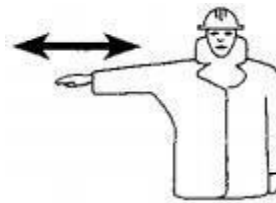

Moving to the right



End



Lifting



Vertical distance



Lowering

3.8.3 Prevention signs

If it's possible the supervisor shall post the mandatory and prohibitory signs when the crane is present on the building site.



Caution: Suspended loads



Safety helmet

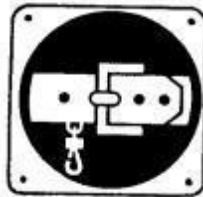

Safety belt



Protective gloves



Protective shoes

No passage



No passage or standing within the crane's radius of action.



Do not remove protective And safety devices



Use by unauthorized Personnel forbidden



Do not work on moving parts



Assembly

Chapter 4

4.1 General assembly information.....	61
4.2 Erection crane tower (1.2m)	68
4.3 Installing chassis.....	76
4.4 Assembling the telescopic cage	86
4.5 Anchorage frame 1.2m.....	101
4.6 Climbing inside the building.....	110

4.1 General assembly information

Particularly bolt connections with high-strength pretension.
(HV bolt connections)

General information

There are numerous bolt connections on a tower crane. It is their task to connect crane components and to transfer forces.

Particular attention must be paid to the bolt connections with high-strength pretension. All bolt connections belong to those parts of the tower crane which are highly important for the operational safety of the crane. Consequently, all these bolt connections must be executed, maintained and checked with the greatest of care.

Bolt connections which are tensioned manually with a wrench

Such bolt connections are connections which are tightened manually with a wrench. They must be checked regularly in order to make sure they are tight and cannot loosen unintentionally. If such a bolt connection loosens up, this may lead to accidents and damage, e.g. if a part of this bolt connection falls down.

Bolt connections with high-strength pretension Definition

A bolt connection with high-strength pretension is a bolt connection consisting of bolts, nuts, washers and possibly also distance bushes, all parts of this connection being made of high-strength material.

All such bolt connections must be tensioned to their prescribed torque. In order to do this, a torque spanner is required to accomplish said prescribed torque.

Places of application

Bolt connections with high-strength pretension are used anywhere where great forces must be transferred from one crane component to another.

Speaking in terms of a tower crane, such components are:

- Slewing ring
- Tower sections
- Possibly also drive units like slewing units and hoist or trolley units erection

4.1.2 Parts belonging to a bolt connection

All parts of a bolt connection are marked separately. Regulations concerning quality and identification are established by national and international standards.

4.1.3 Bolts

Bolts must be identified according to the international standard ISO 898 part.

Property class, e.g. 8.8, 10.9 or 12.9 must be stamped on the bolt head as indicated in illustration:

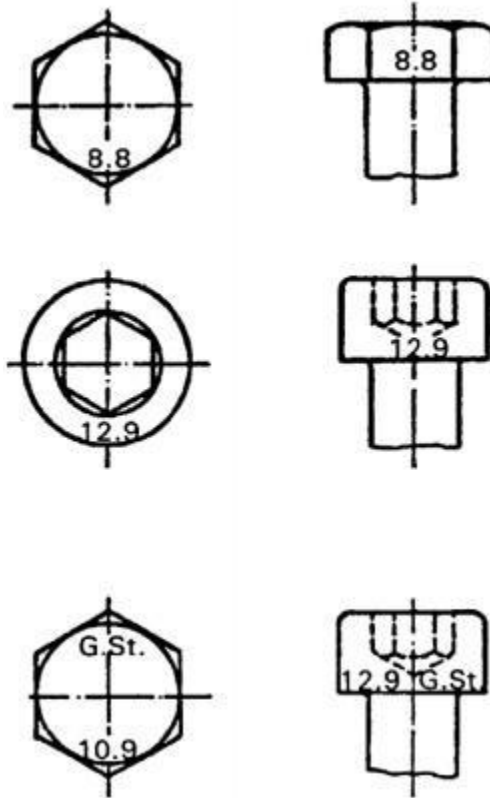

4.1.4 Nuts

All nuts must be identified according to international standards ISO 898 part 2.

According to ISO 898 part 2 symbols are also permitted for identification of the property class of nuts, however due to their multifariousness it is not possible to list them all in this technical description. Only nuts of the property class as stated in illustration below are permitted for use in a high-strength bolt connection.

Furthermore the nuts must also be furnished with a sign of origin from the nut manufacturer. Normally such identification is placed close to the identification of the property class.



Example:

- | | |
|--------|-------------|
| Nut 8 | - bolt 8.8 |
| Nut 10 | - bolt 10.9 |
| Nut 12 | - bolt 12.9 |

4.1.5 Washers

Since there are no ISO standards for washers as yet, washers produced for high strength bolt connections are identified with RV in Germany, as shown in illustration below.



Only washers made of high-strength material may be used for high-strength bolt connections. Such material must be in accordance with the material listed in

paragraph "Bolts and nuts". We recommend only to use washers supplied by BKT. If washers of other makes are used, please make sure that their Property class is in accordance with the property class of the mating bolts and nuts.



Washers for bolt connections must have one side chamfered in order to avoid any damage of the filleting of the bolt head. For this reason the chamfered must always point towards the bolt head.

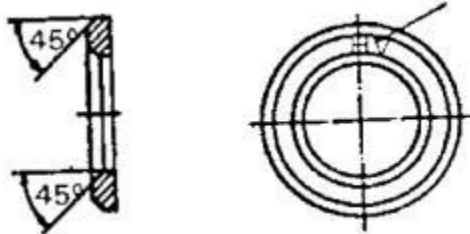

Distance bushes

For some high-strength bolt connections distance bushes are required for constructional reasons. These are part of manufacturers scope of delivery. They must be installed according to the instructions in this operation manual.

4.1.6 Checking the different parts of bolt connections prior to installation

Condition of parts belonging to a bolt connection

All parts of a bolt connection must be cleaned and checked visually before they are fitted.

This visual check must comprise the threads of the bolt, the threads of the nut, the seat of the nut on the bolt and the corner surface of the bolt shaft to the bolt head support.



Damaged bolts or nuts must never be used. Bolts with corrosion on shaft and in their thread as well as rusty nuts must not be used.

Damaged bolts or nuts or bolts and nuts with only signs that they may be damaged must not be used.

Lubrication of the bolt connection elements

All bolts, nuts and washers must be lubricated with grease on a molybdenum desilphide basis every time before they are fitted. This provides an even frictional resistance and this, in its turn, guarantees a correct pretension of the bolt connection at any time.



Grease to be applied on the threads of bolts and nuts and the support surface of the nut.

Note!

If the prescribed starting torque is applied on the bolt head, please do not fail to lubricate also the support surface of the bolt head.

Reuse of parts of the bolt connections

All parts of the bolt connections which were tensioned to the torque prescribed by ourselves may be reused when erecting the crane anew.

This is, however, on the condition that all parts are checked according to paragraph "Condition of elements belonging to a bolt connection" and show no damage.

4.1.7 Tensioning of bolt connections

Correct tensioning is an absolute must

A bolt connection can only fulfil its task provided it has been pretensioned to correct torque. The bolt is lengthened through the torque and the crane parts to be connected are pressed together, thus accomplishing an intensive tension of these parts.

The working life of a bolt depends highly on whether the correct torque was applied in thus the pretension achieved.

A torque which is too high or too low may lead to an early failure of the bolt connection.

The torque

In order to achieve the prescribed pretension, the bolt connection must be tightened using a torque wrench.

The torque to be applied varies according to type and size of the bolts and nuts to be inserted. Table enclosed in this operation instruction. Please confer this table for correct torque for each bolt used.

When conferring the a.m. table, please bear in mind that the quality classes as per ISO 898 part 1 and part 2 were used as basis.

The wrench size across flats s as per enclosed table can be used to determine

Non-lubricated bolts must under no circumstances be used in high-strength pretensioned bolt connections.

whether you have a bolt as per DIN 6914, DIN 931 or DIN 912.

Torque wrench



The torque prescribed in each case can only be applied using a torque wrench. This torque wrench must offer the possibility to set the torque as well as the tensioning direction.

If higher torques are required, multipliers must be used. Such multipliers are also called power drivers.

With such multipliers torques up to 9 500 Nm (950 mkg) can be achieved.

These torque wrenches must be checked from time to time and adjusted if necessary.



The tensioning torques must never diverge by more than +/- 10%.

A further possibility is to apply required torque using a hydraulic torque wrench

When using a hydraulic torque wrench the pressure within the hydraulic system is indicated in a manometer. To a certain manometer pressure there is an appropriate torque. The relation between manometer pressure and torque is to be found in the appropriate table which is part of the information supplied for said hydraulic.

4.1.8 Inspection of installed bolt connections

The necessity to carry out inspections

Any bolt connection can loosen up.

This is also the case for HV-bolt connections. If these high-strength pretensioned bolt connections loosen up, this may lead to complete or partly loss of the pretension. If the pretension gets completely or partly lost, this leads to a premature fatigue of the bolt material. This represents a danger of a fatigue breakage of the bolt. Also the joint may get ajar and the connection loosens up all together.

Initial and repeated inspections of installed bolt connections

Initial inspection

Due to settlements in the bolt connections of new cranes and new crane parts this initial inspection of all bolt connections must be carried out 3 weeks upon completed first erection at least. This inspection must be carried out using the same torque wrench or multiplier.

The nut (or bolt) is then retensioned with a rated moment according to table 1. If no further tension of the bolts is possible, then it may be assured that the connection is ok. If it is possible to retension the bolts, the connection must be loosened up completely, new lubrication must be carried out. Then fasten the bolt connection anew and apply the appropriate torque.

Repeated inspections

Repeated inspections must be carried out each time the crane is erected anew and furthermore at least once a year. If the crane works with more than one shift a day, such inspections must be carried out with shorter intervals, as appropriate. Such inspections are carried out by loosening up the bolt connections at

random, taking out and checking the connecting bolt as specified in paragraph "Condition of the bolt connection elements".

Upon having done so, the bolt is relubricated, reinserted and tensioned to prescribed torque.

Visual inspection

Repeated inspections by visual check ups must take place at least once every three months. It is then sufficient to make sure no gaps have occurred between the tensioned parts, which would mean that the bolt connections have loosened up.

Replacement of bolt connecting elements

If on any connecting level, which means anywhere where crane parts are connected to each other (e.g. tower sections, roller bearing slewing ring) broken bolts or bolts with incipient fractures are discovered, then all bolts on this connecting level must be replaced.

Regulations for prevention of accidents

Regular, scheduled inspections are prescribed in all regulations for prevention of accidents and it is emphasized that the crane manufacturer's instructions must be strictly observed.

Such necessary, regular inspections were treated in the above paragraphs.

Bolt connections

For greased bolt connections with metrical ISO thread according DIN 13 or ISO 261 with or without a galvanized coat the following starting torques are applicable.

4.1.9 Table 1

Starting torques:

Thread	Property Class 8.8 (8G) DIN 931/933 DIN 912		Property Class 10.9 (10K) DIN 6914 DIN 931/933 DIN 912				Property Class 12.9 (12K) DIN 931/933 DIN 912	
	mkg	Nm	mkg Nm	Nm	mkg	Nm	mkg Nm	Nm
M12	5.2	51	9.8	96	7.4	73		
M14	8.4	82			13.0	127		
M16	14.0	137	24.7	242	19.1	187		
M18	18.0	177			26.0	255		
M20	25.9	254	48.3	474	37.0	363		
M22	35.8	351	66.0	647	51.1	501		
M24	44.9	439	83.0	814	64.0	628		
M27	70.0	686	123.0	1206	100.0	981		
M30	95.8	939			136.8	1342		
M33	130.9	1284			187.0	1834	230.8	2264
M36	167.3	1641			239.0	2344	296.1	2904
M39	217.3	2131			310.4	3044	383.6	3762
M42	268.4	2632			383.4	3760	476.3	4670
M45	335.4	3289			479.1	4693	594.8	5833
M48	403.6	3958			576.6	5655	717.8	7039
M56					900.0	8830		

4.1.10 Table 2

Wrench sizes across flats "s"

DIN 931, 933, 934
DIN 6914, 6915

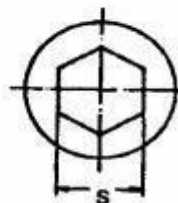
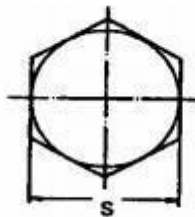

DIN 912

Bolts as per DIN 6914 and their mating nuts according DIN 6915 have a bigger wrench size across flats than bolts as per DIN 931 and their mating nuts according DIN 934.

The wrench sizes across flats "s" are listed in the table below:

Rated diameter Of thread mm	Wrench size across flats for bolts according 931/933 for nuts according DIN 934 mm	Wrench size across flats and bolts according DIN 6914 and nuts according DIN 6915 mm	Wrench size across flats for inner hexagon bolts according DIN 912 mm
M12	19	22	10
M14	22	-	12
M16	24	27	14
M18	27	-	14
M20	30	32	17
M22	32	36	17
M24	36	41	19
M27	41	46	19
M30	46	50	22
M33	50	-	24
M36	55	60	27
M39	60	-	-
M42	65	-	32
M45	70	-	-
M48	75	-	36
M56	85	-	-

4.2 Erection crane tower (1.2m)

Mast (Dimensions and weights)

4.2.1 General notes

The dimensions and weights given in the tables on the following pages correspond to:

- The first line of each group indicates the dimensions and weight of the component assembled with the parts as they are shown in the drawing.
- The following lines indicate the dimensions and weights of the main parts according to representation.
- The direction of dimensions L, l and h with respect to the mark concerns the main parts only.

Important: The sum of the weights of the main parts is lower than the weight of the equipped component because the weight of pins, bolts, small accessories, ect. Is not taken into account.

4.2.2 Basic mast SR24E

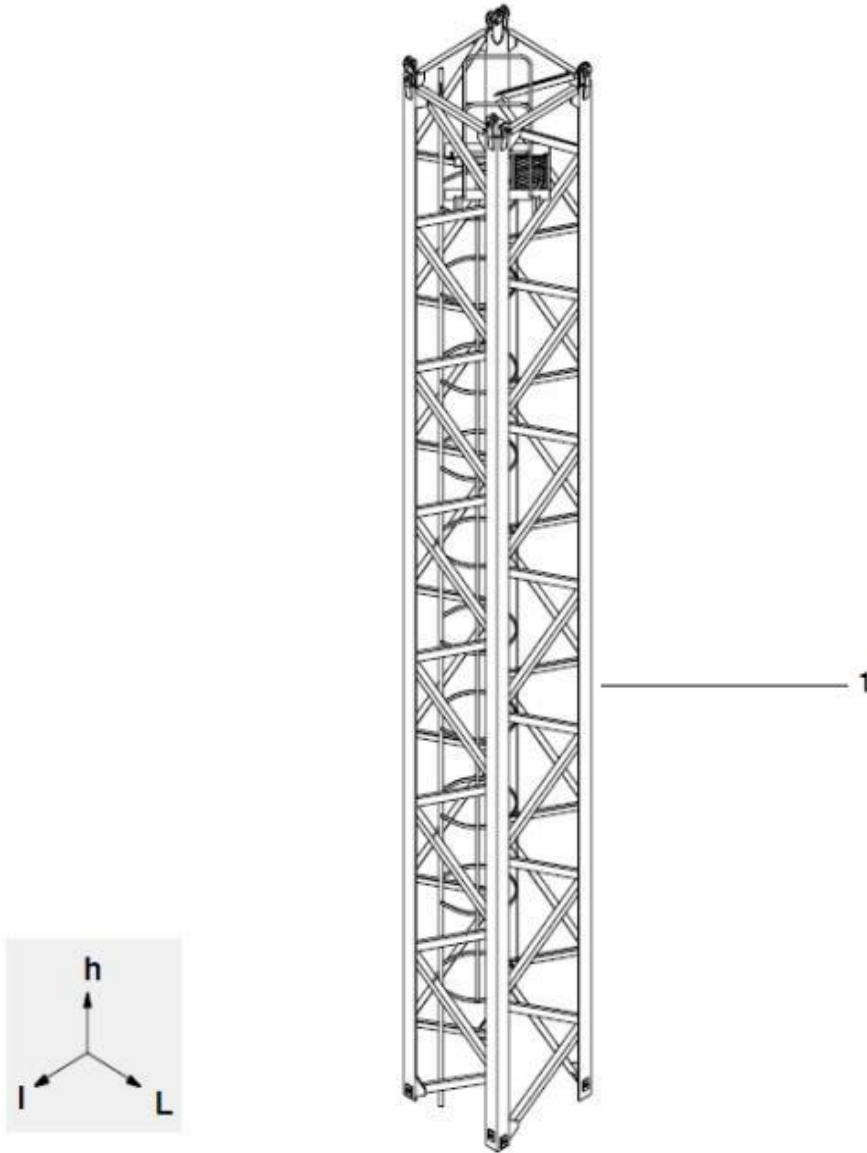

No.	Quantity	Designation	L	i	h	P (Kg)
		Complete tower section SR24 E	1200	1200	10700	2710
1	1	Unequipped tower section SR24 E	1200	1200	10700	

4.2.3 Tower section S24C1(3.0m)

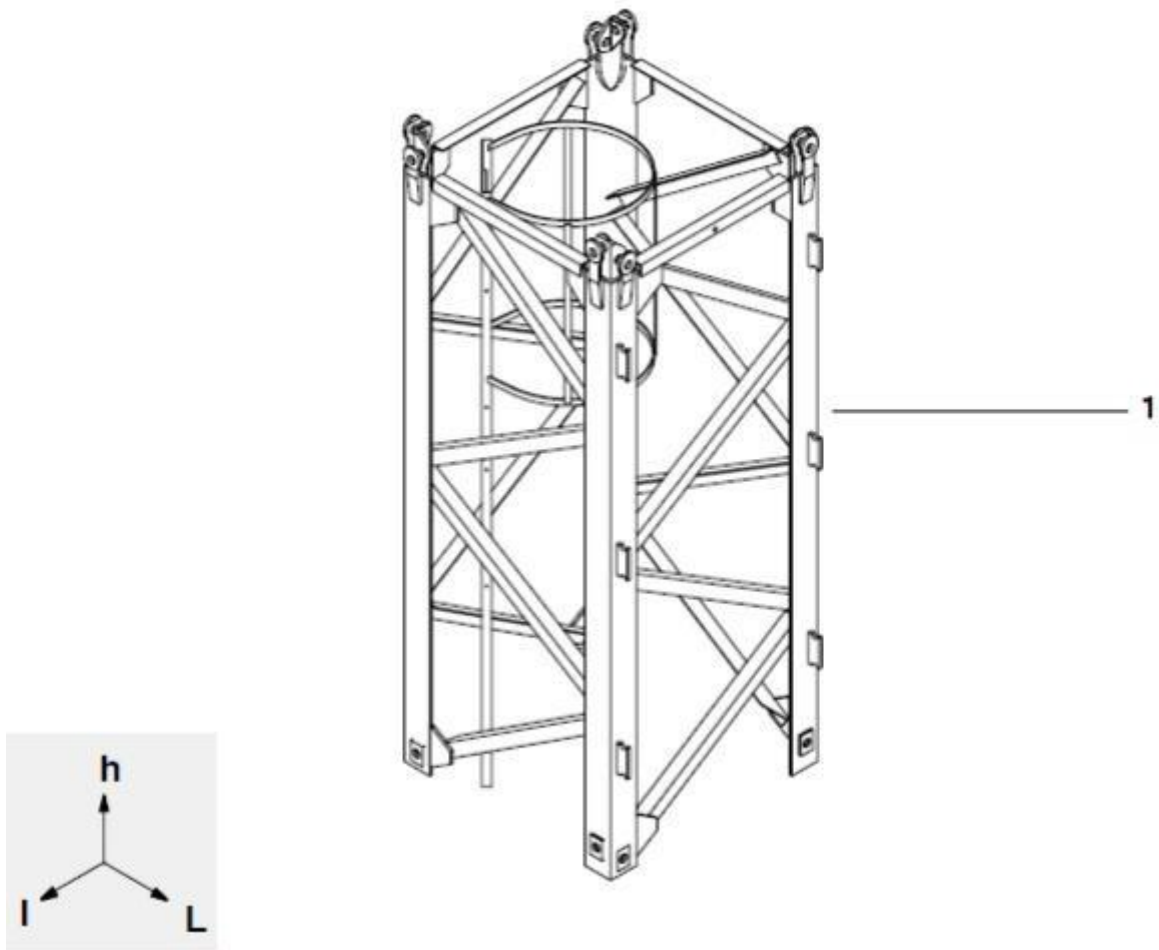

No.	Quantity	Designation	L	i	h	P (Kg)
		Complete tower section S24C1	1200	1200	3200	890
1	1	Unequipped tower section S24C1	1200	1200	3200	

4.2.4 Tower section S24C2(3.0m)

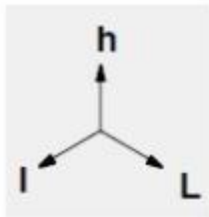
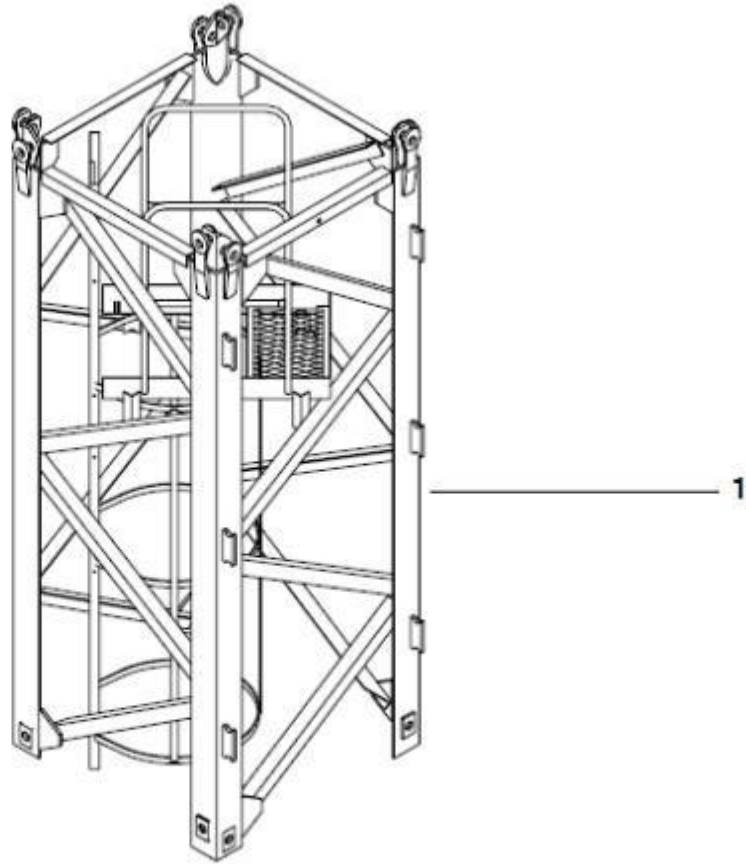

No.	Quantity	Designation	L	i	h	P (Kg)
		Complete tower section S24C2	1200	1200	3200	890
1	1	Unequipped tower section S24 C2	1200	1200	3200	

4.2.5 Telescoping mast (1.5m)

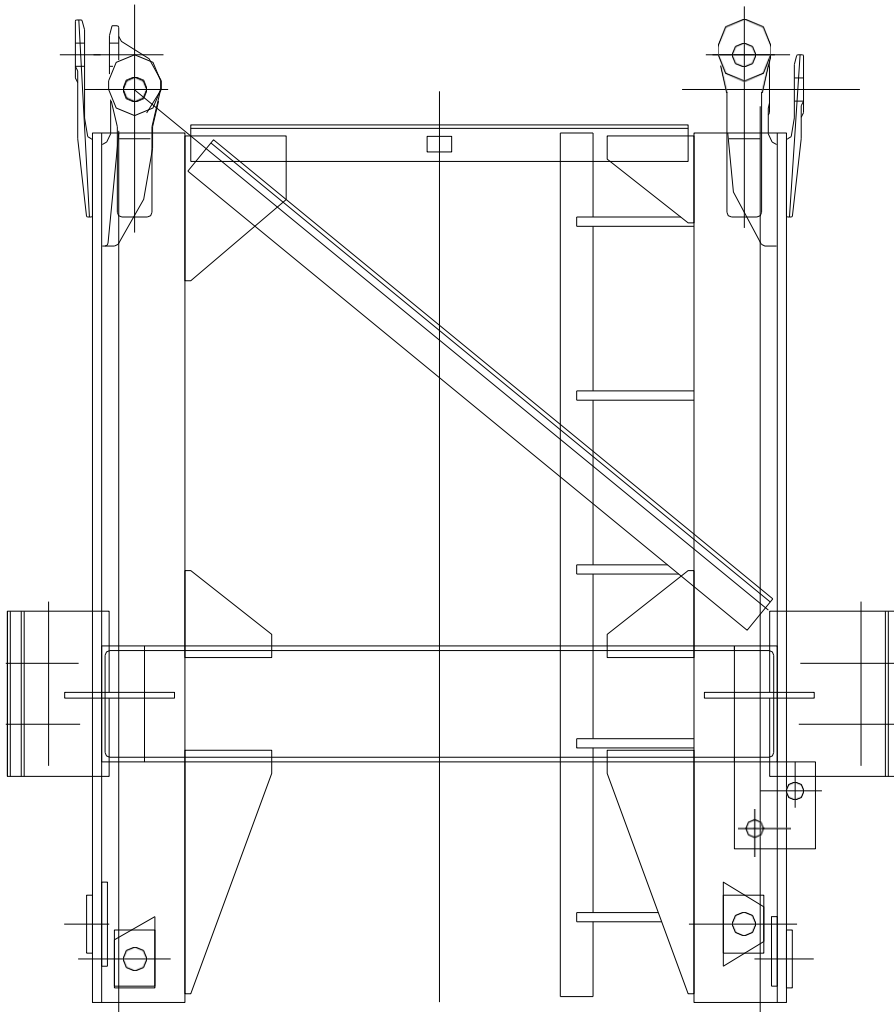

No.	Quantity	Designation	L	i	h	P (Kg)
		Telescoping mast	1580	1500	1700	630
1	1	Unequipped telescoping mast	1580	1500	1700	

4.2.6 Access

The mono block mast accesses are welded into the mast sections.

In any case of mast composition with 3 m mast sections, the mast sections S24 C1 with a simple access (1) must be alternated with the mast sections S24 C2 equipped with an access with resting platform (2), in order to obtain a distance of 12 m between the resting platforms (Detail A – Figure 1).

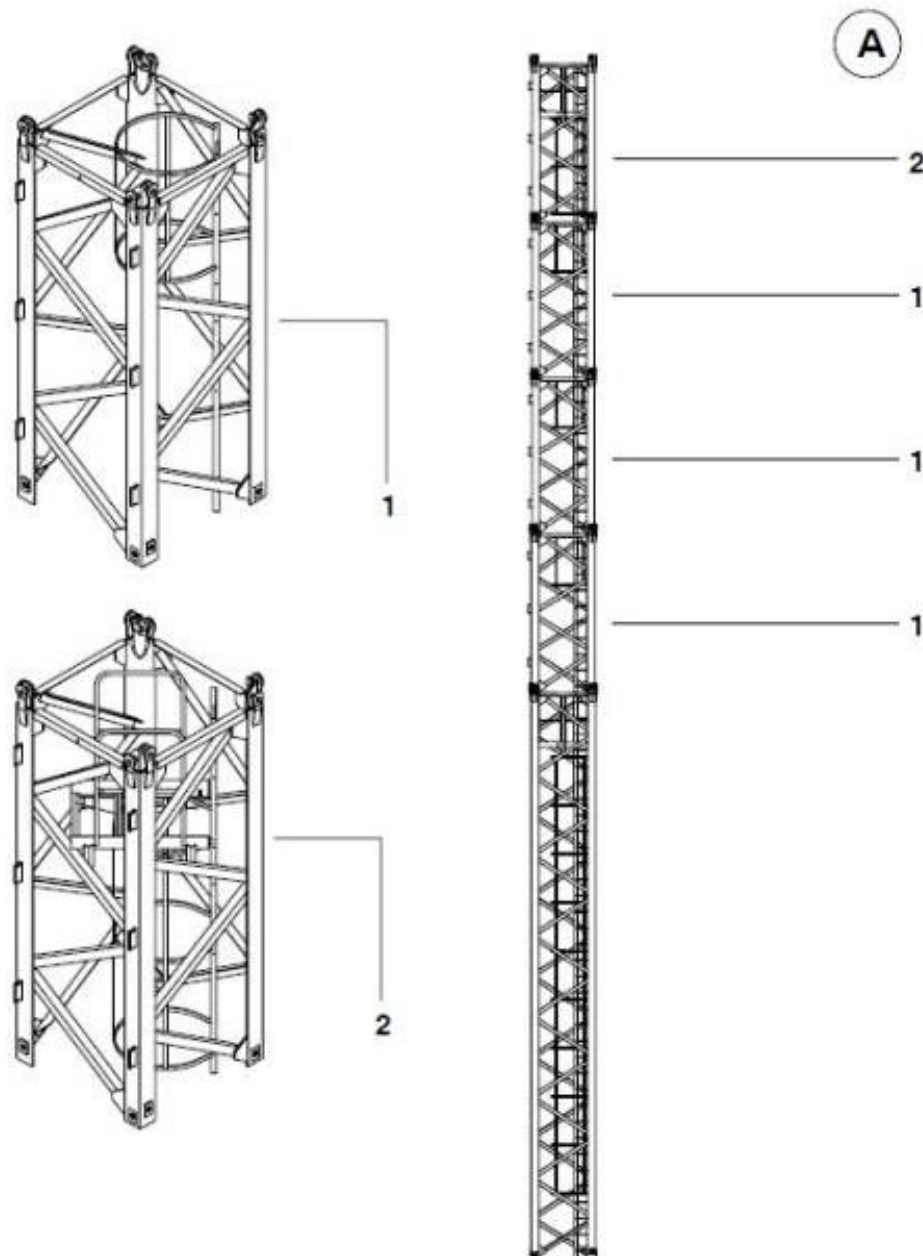

Figure 1.

In certain cases of the mast composition, the back loop L900 (1) is located in the 10.5m tower section (Detail A – Figure 2).

It can be fitted into the S24 C1 mast sections with standard access (3) in the position B (Figure2).

It can be fitted into the S24 C1 mast sections with standard access (3) in the position C

(Figure2).

Fix the back loop 700x900 (1) onto the ladder (4) of the standard mast section by means of 4 screws

HM 8x25 (5), 4 washers W8 (6) and 4 nuts HM8 (7) (Detail D – Figure 2).

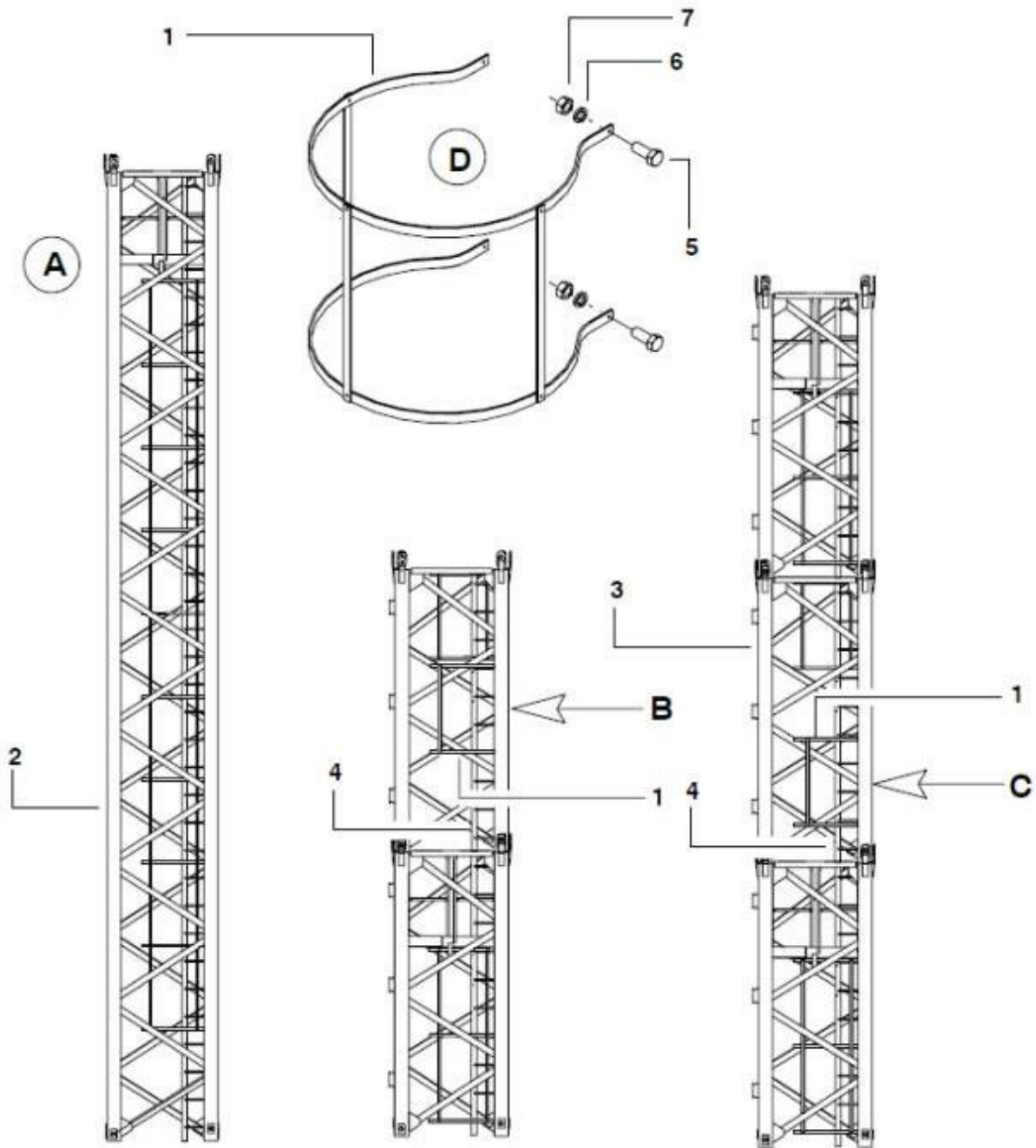
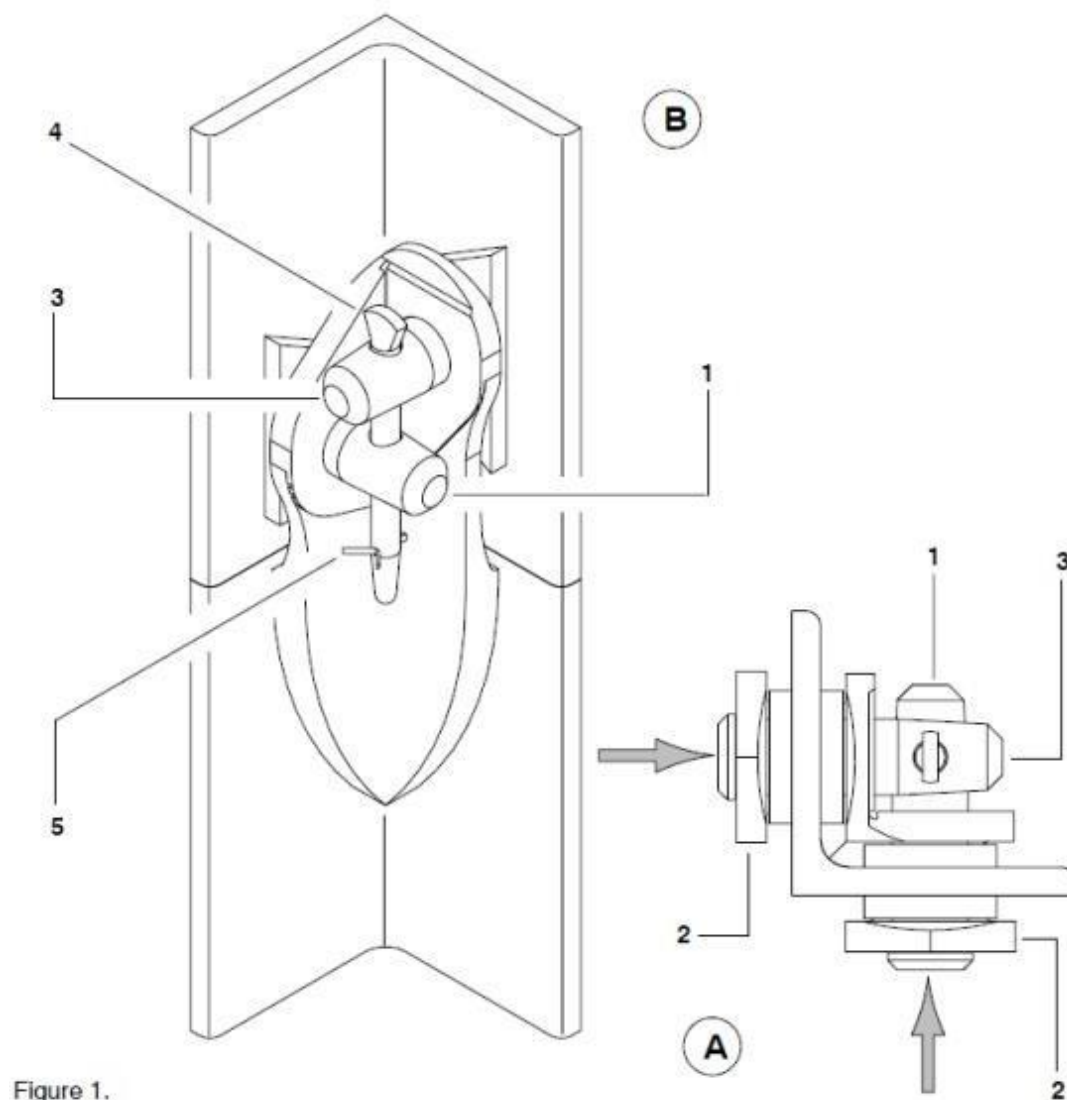

Figure 2.

4.2.7 Fish plating

- Ensure the cleanness of the bearing surfaces of the holes and shafts which must be freed from old grease and burrs.
- Introduce the headed shaft (1), drive in until it abuts against the fishplates (2). Proceed in the same way for the second headed shaft (3) (Detail A – Figure 1).
- The shafts (1) and (3) are locked by means of a pin (4); block the pin (4) using a split pin (5) (Detail B – Figure 1).



4.3 Installing chassis

□ General data weights and heights

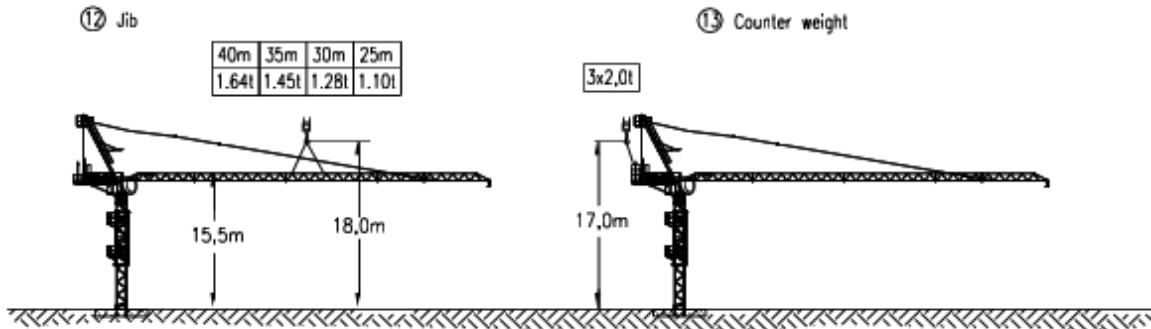
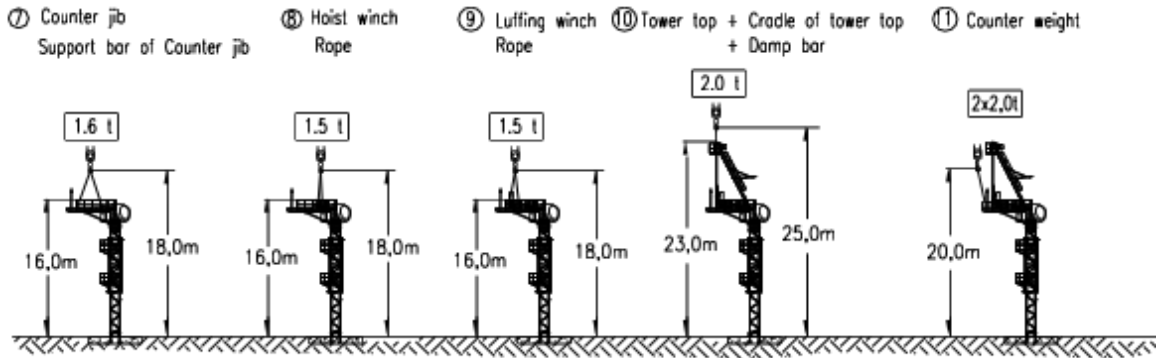
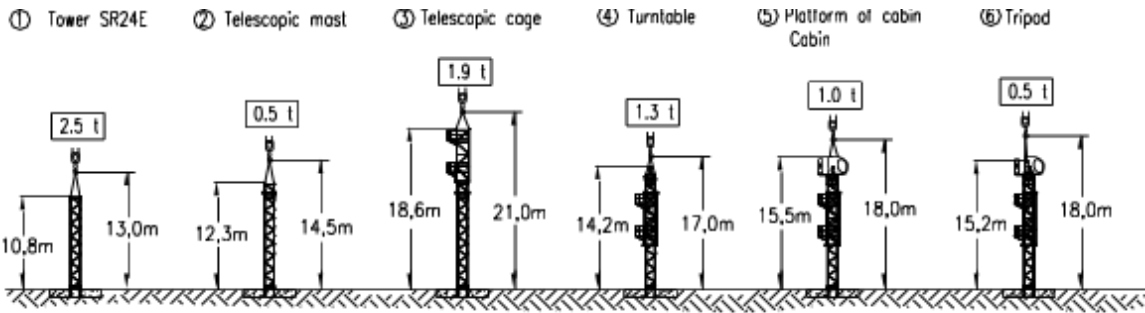

⑭ Assembly complete ⑮ Adjustment of safety devices

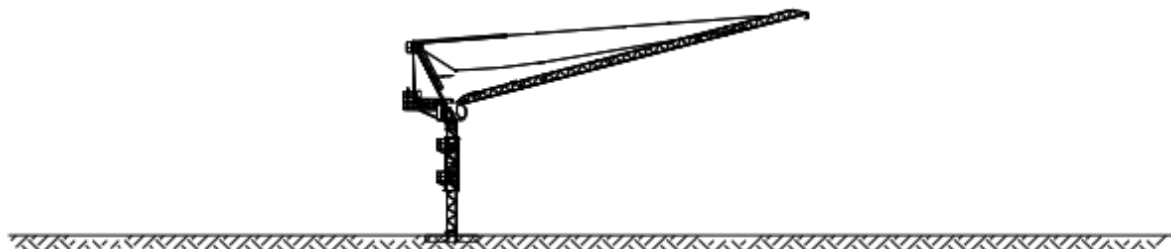

4.3.1 Assembly of telescopic cage (Drawing 1)

If the crane must be climbing install telescopic cage over Basic Mast. Assembly of telescopic cage - see chapter 4 - climbing.

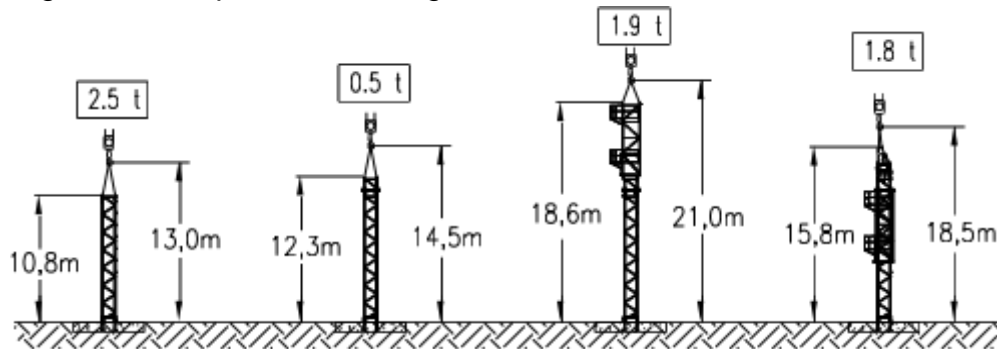

Drawing 1

4.3.2 Assembly of turntable and platform of cabin (Drawing 2)

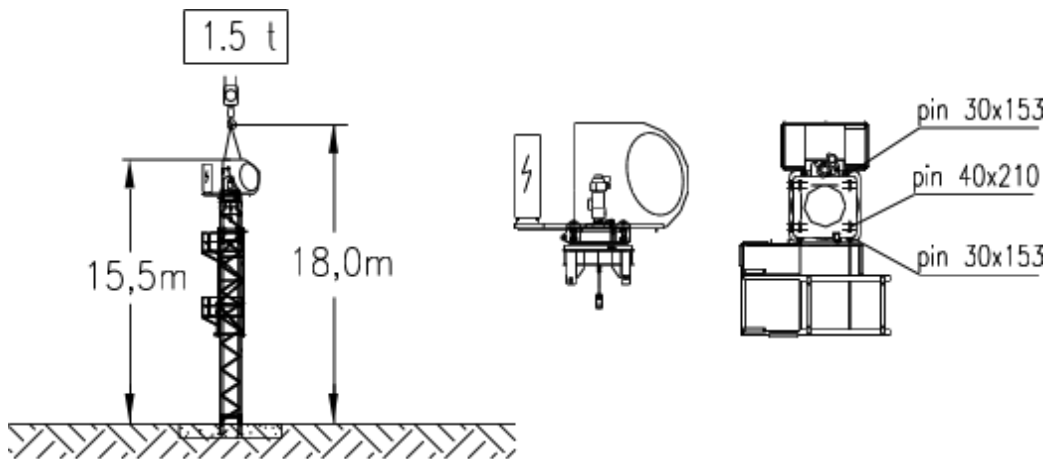

Drawing 2

4.3.3 Assembly of Counter jib (Drawing 3)

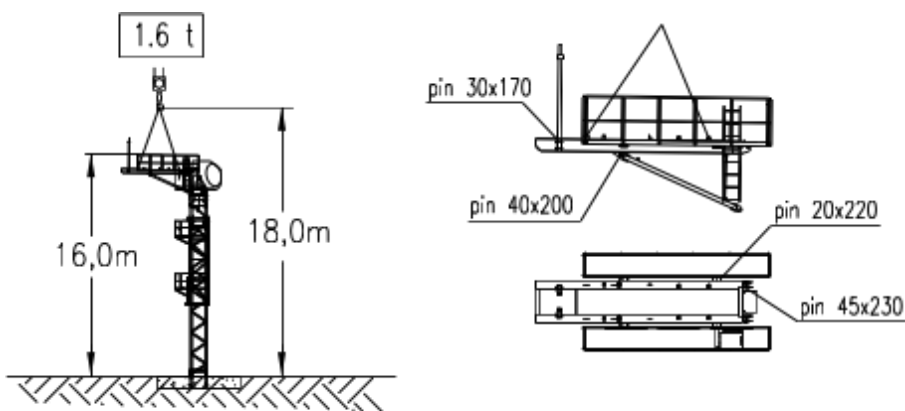

Drawing 3

4.3.4 Assembly of Hoist winch (Drawing 4)

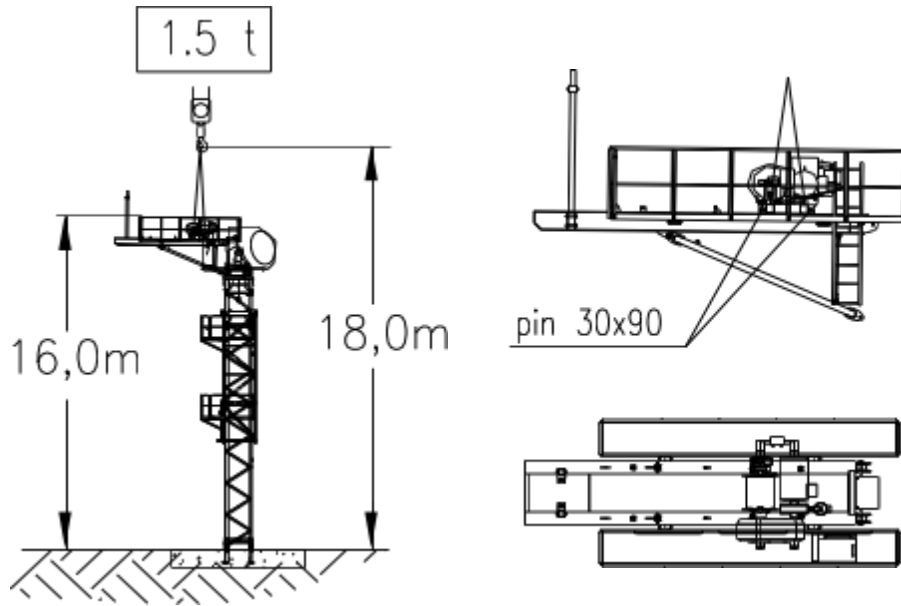

Drawing 4

4.3.5 Assembly of luffing winch (Drawing 5)

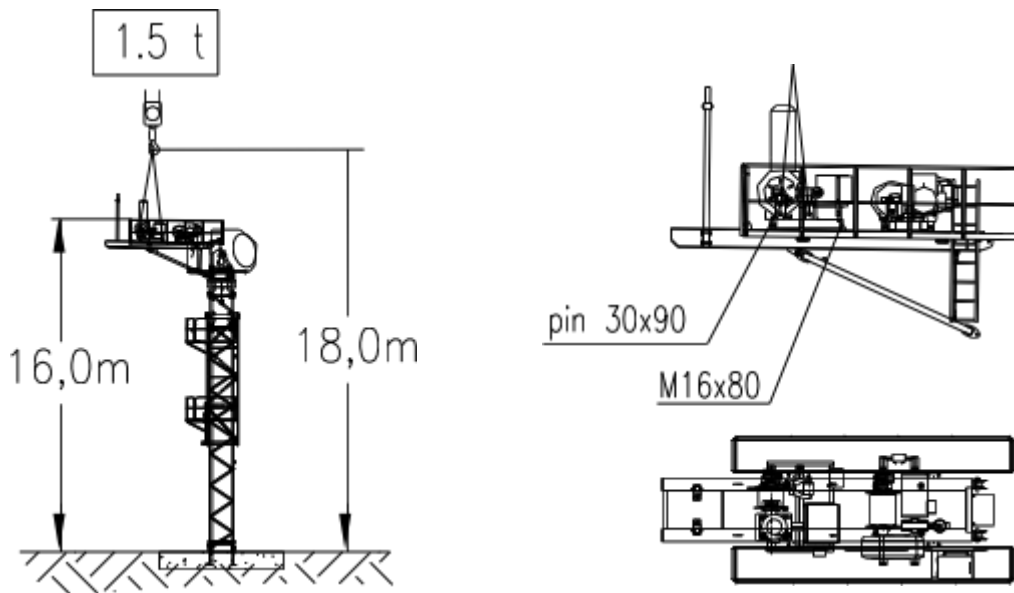

Drawing 5

4.3.6 Assembly of tower top (Drawing 6)

4.3.6.1 According to the following program, fit the tower top, cradle of tower top, support bar of tower top and damp bar together on the ground (Drawing 6-1).

4.3.6.2 Make a pin connection between tower top and top of slewing. (Drawing 6-2)

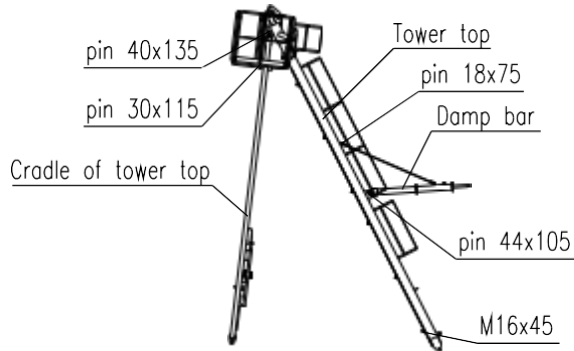

Drawing 6-1

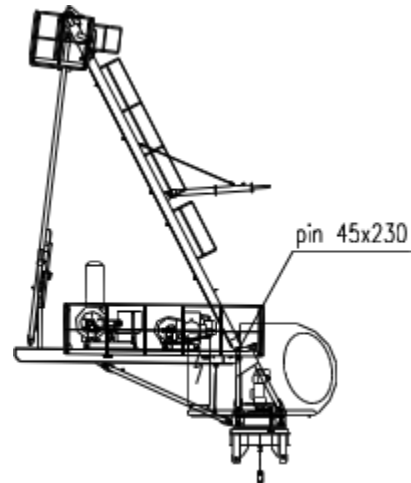

Drawing 6-2

4.3.6.3 Connect the cradle of tower top with support bar of tower top, the cradle of tower top with counter jib, and the support bar of tower top by pins. (Drawing 6-3)

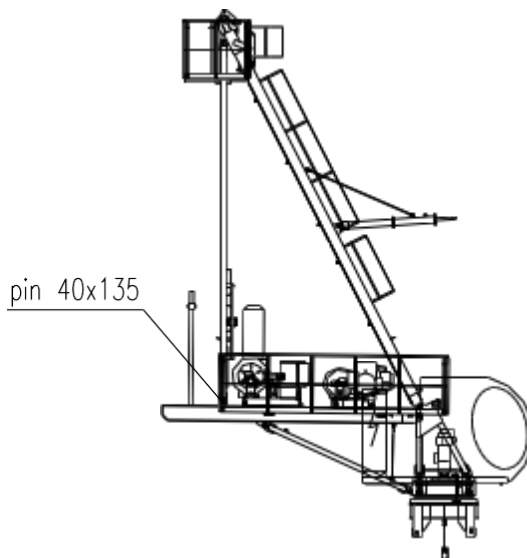

Drawing 6-3

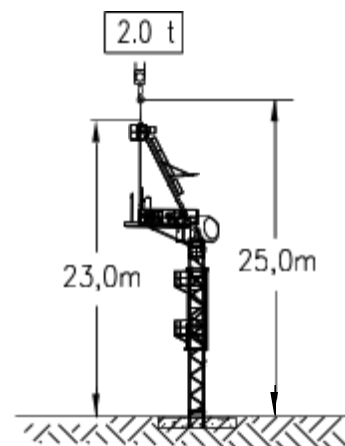

Drawing 6

4.3.7 Assembly of Counterweight (Drawing 7)

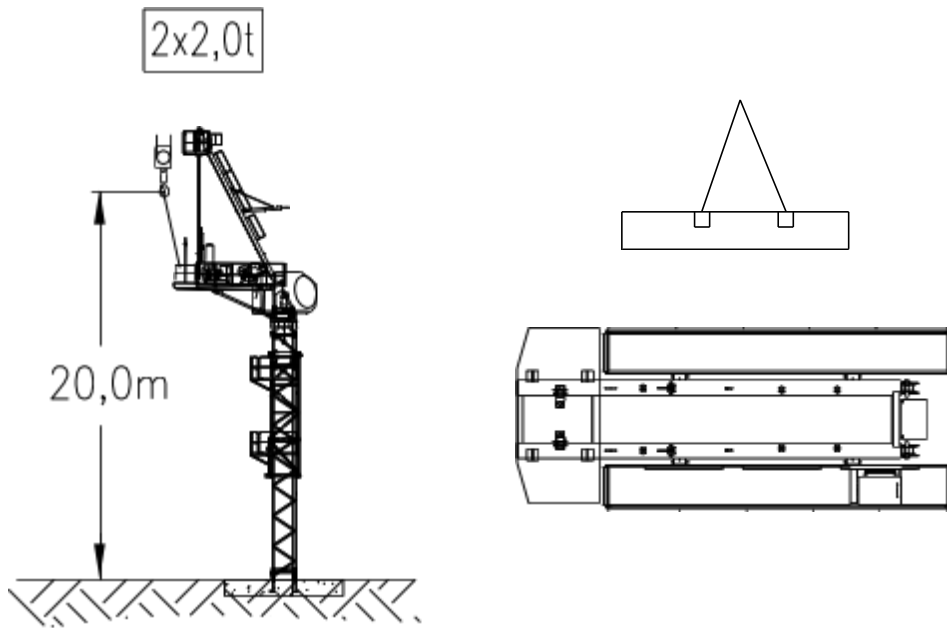

Drawing 7

4.3.8 Assembly of Jib (Drawing 8)

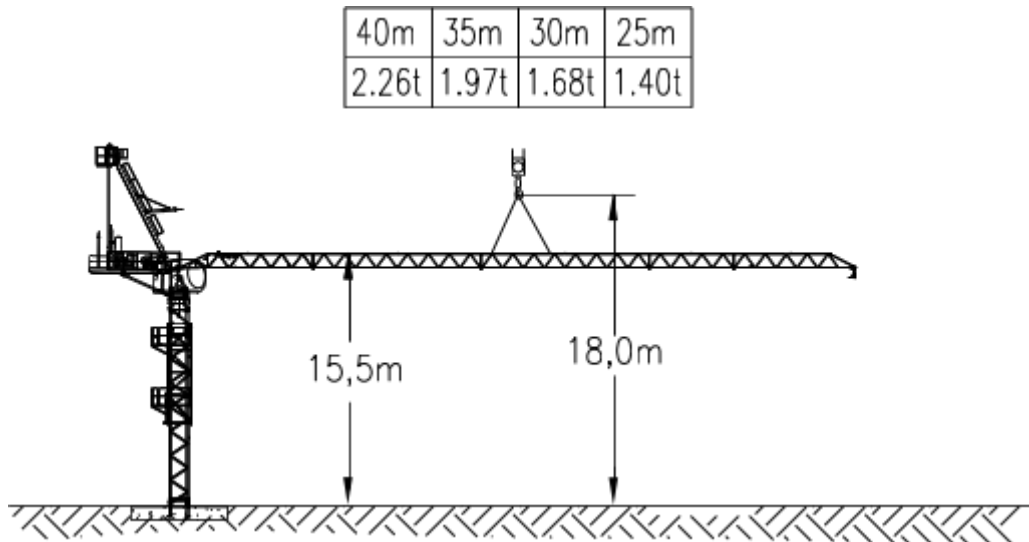

Drawing 8

4.3.8.1 Assembly of Jib 40m (Drawing 8-1)

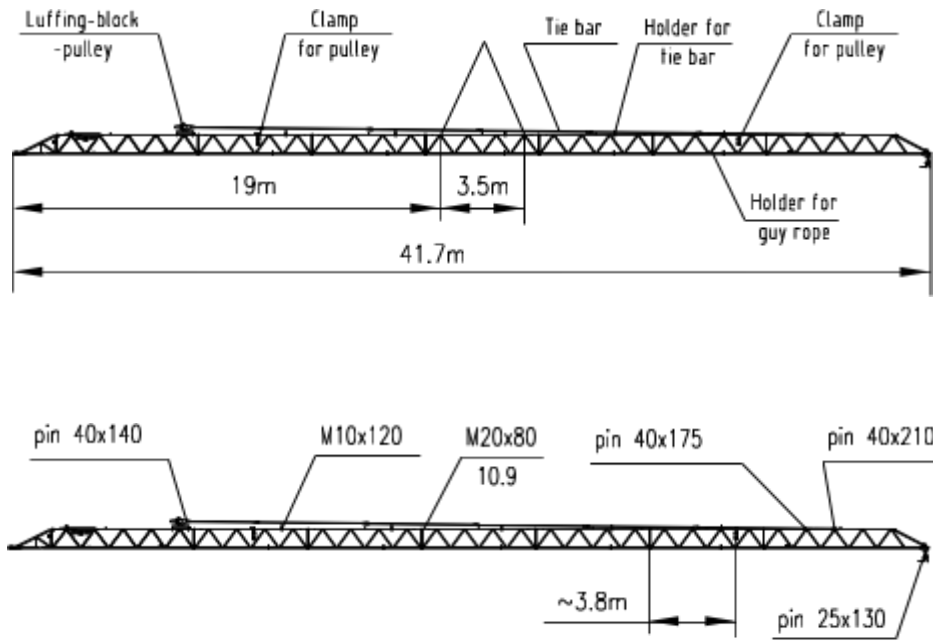

Drawing 8-1

4.3.8.2 Assembly of Jib 35m (Drawing 8-2)

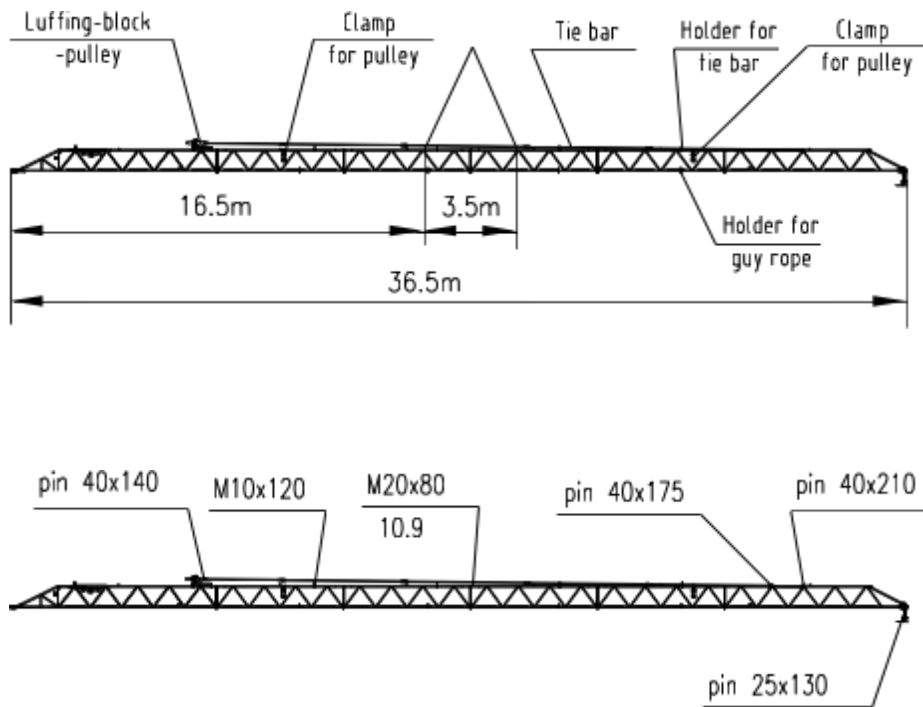

Drawing 8-2

4.3.8.3 Assembly of Jib 30m (Drawing 8-3)

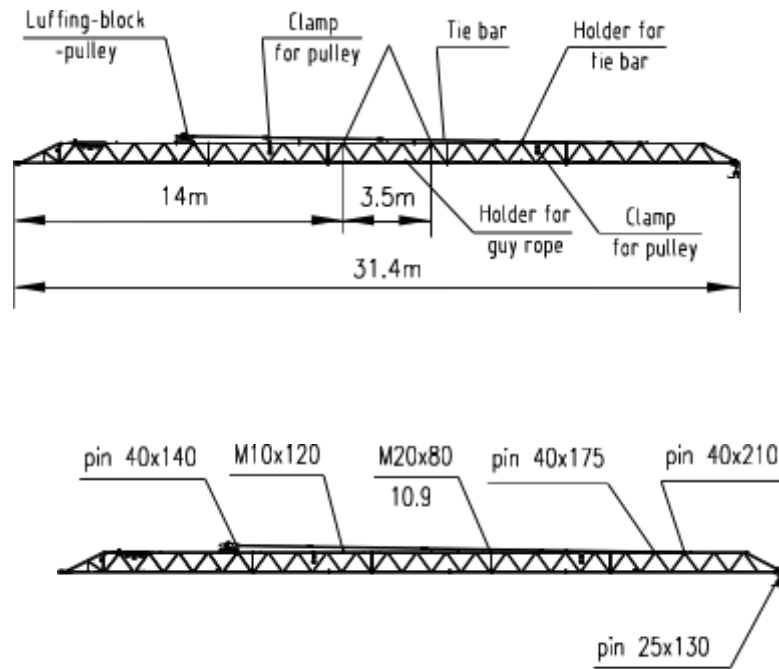

Drawing 8-3

4.3.8.4 Assembly of Jib 25m (Drawing 8-4)

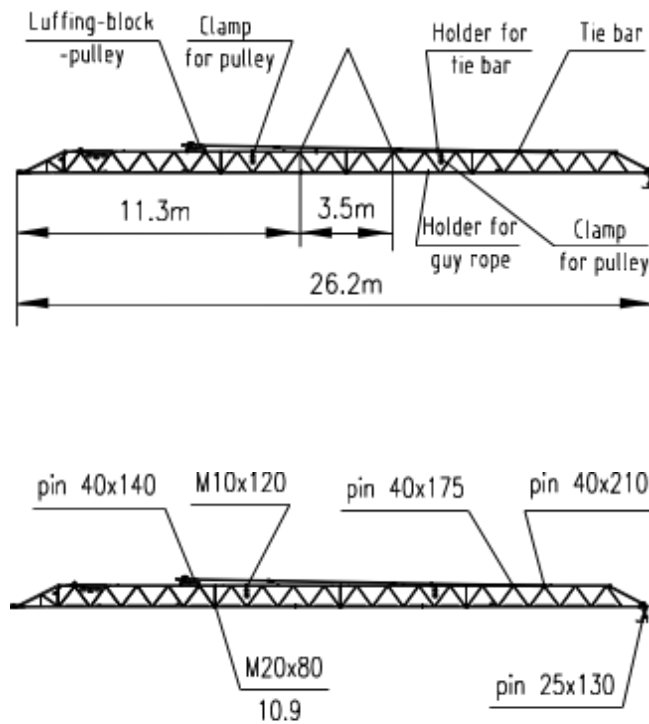

Drawing 8-4

4.3.9 Assembly of Guy rope (Drawing9)

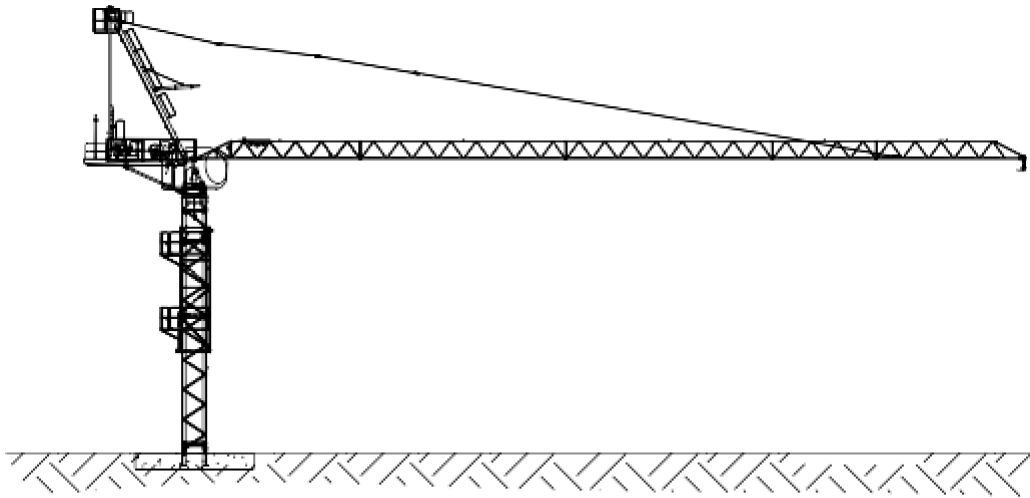

Drawing 9

4.3.9.1 Preassembly of Guy rope (Drawing9-1)

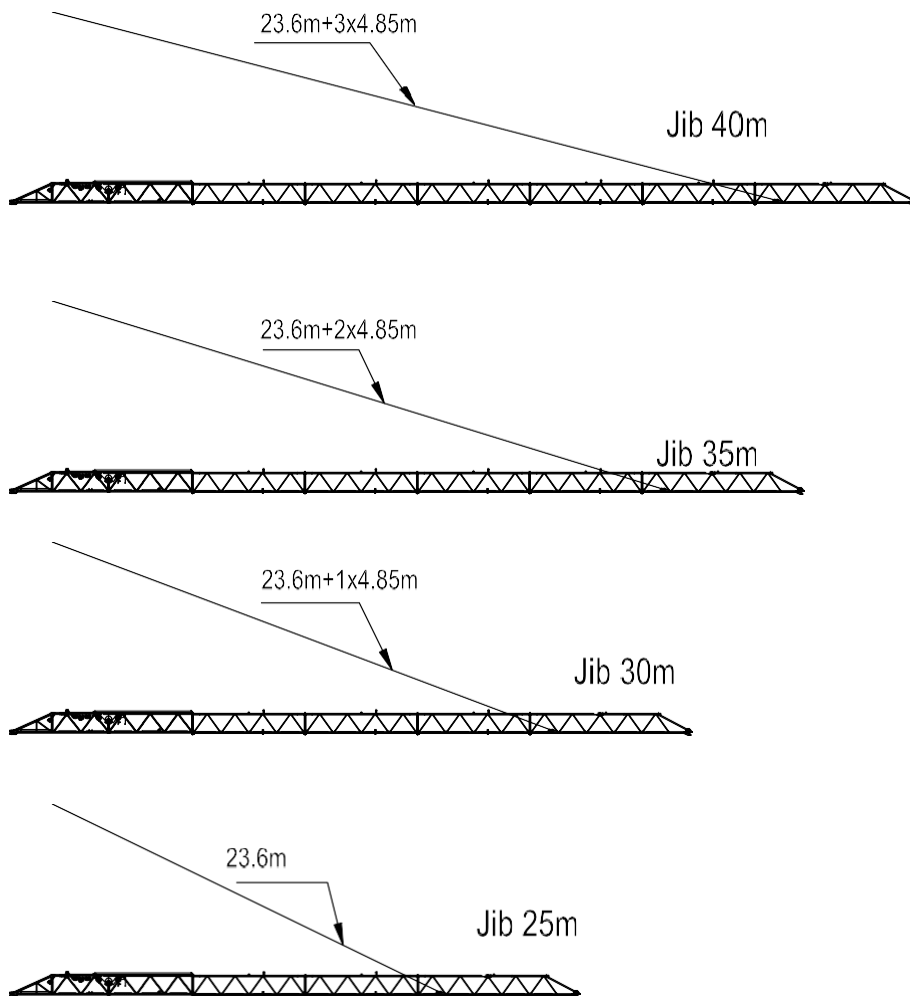

Drawing9-1

4.3.10 Assembly of Counterweight (Drawing 10)

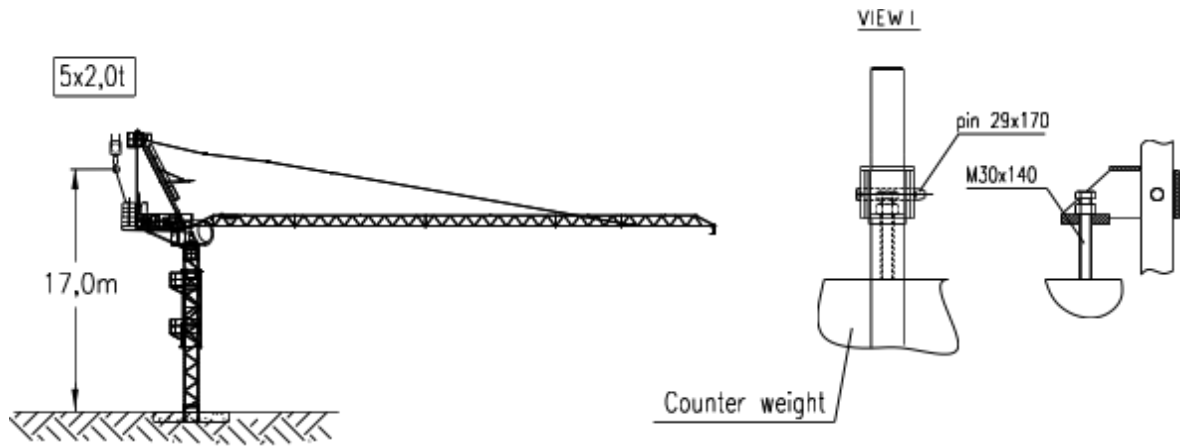

Drawing 10

4.3.11 Reeve of luffing rope (Drawing 11)

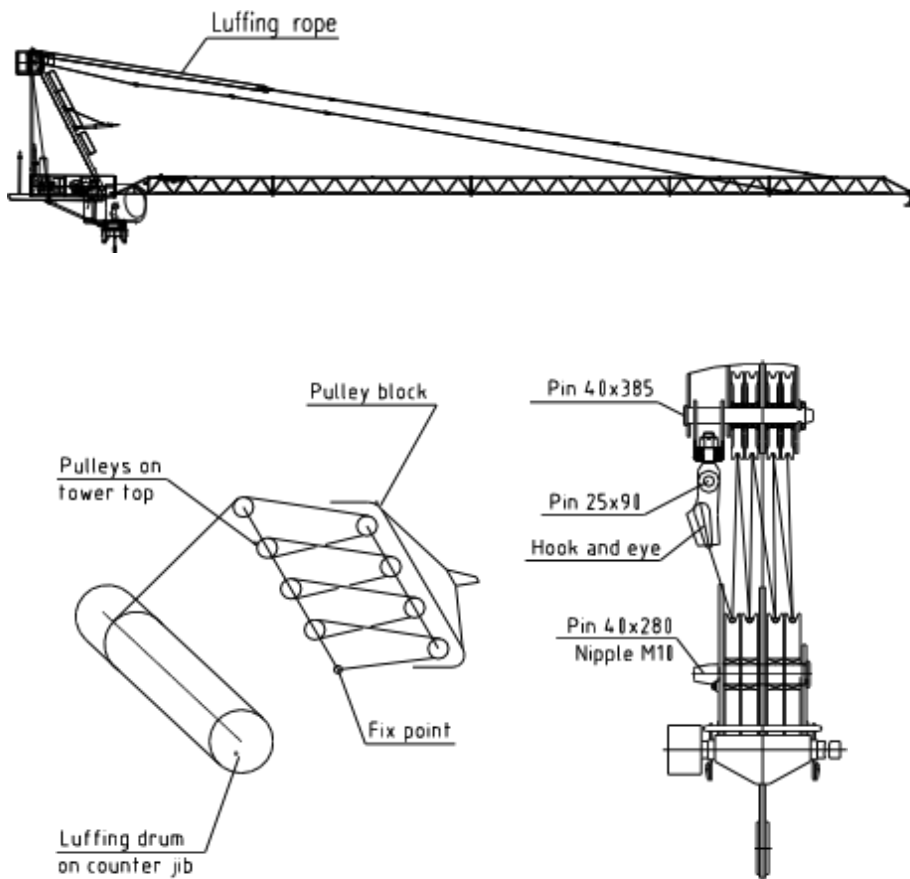

Drawing 11

4.3.12 Reeve of hoist rope (Drawing12)

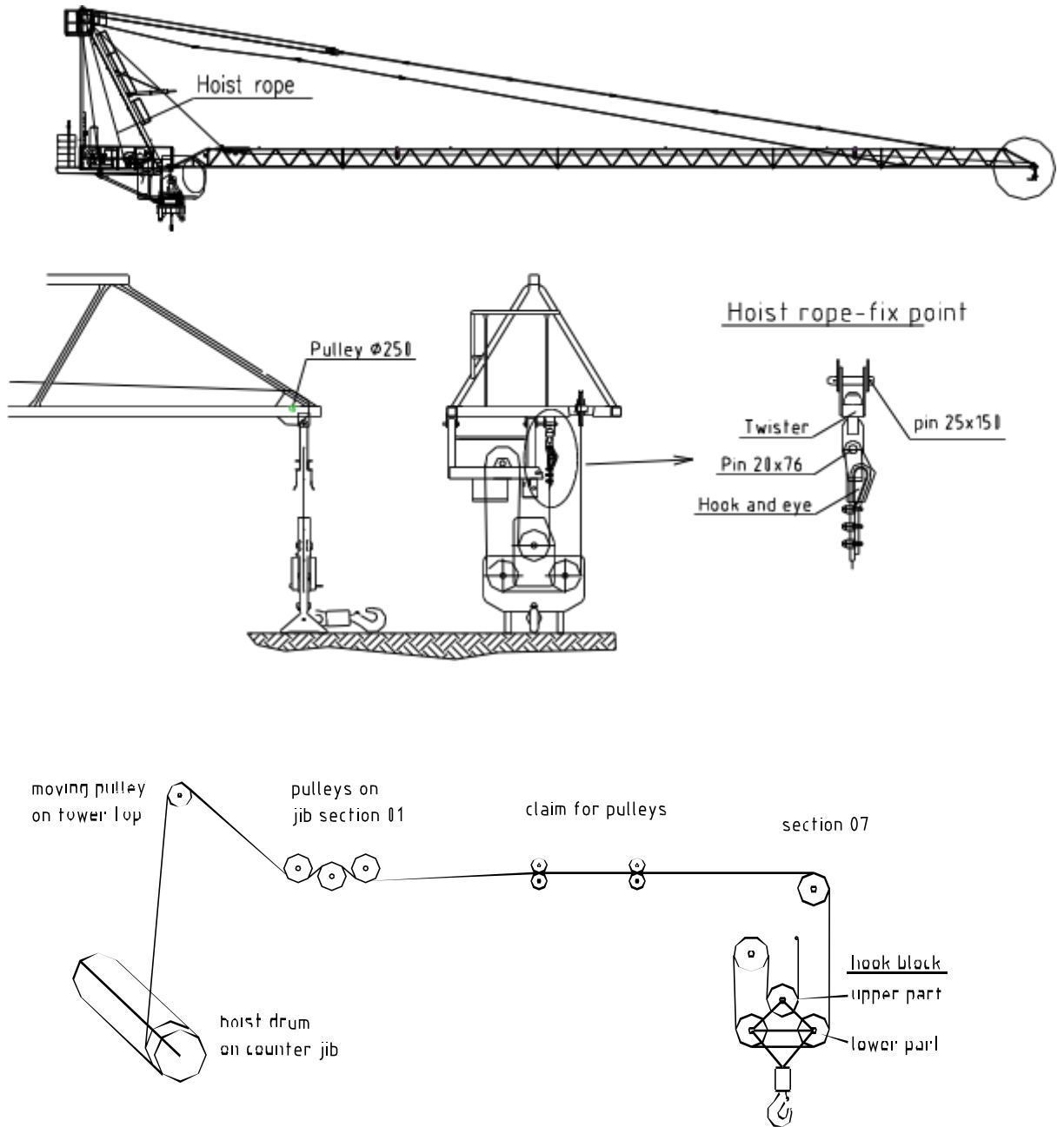

Drawing 12

4.3.13 Untie the guy rope

Turn the jib to approximately 45° , take the guy rope apart in I, one is $2 \times 4.85\text{m}$, fixed it on the head of tower (as A), the other is $1 \times 4.85\text{m} + 23.6\text{m}$, fixed it on the jib (as B).

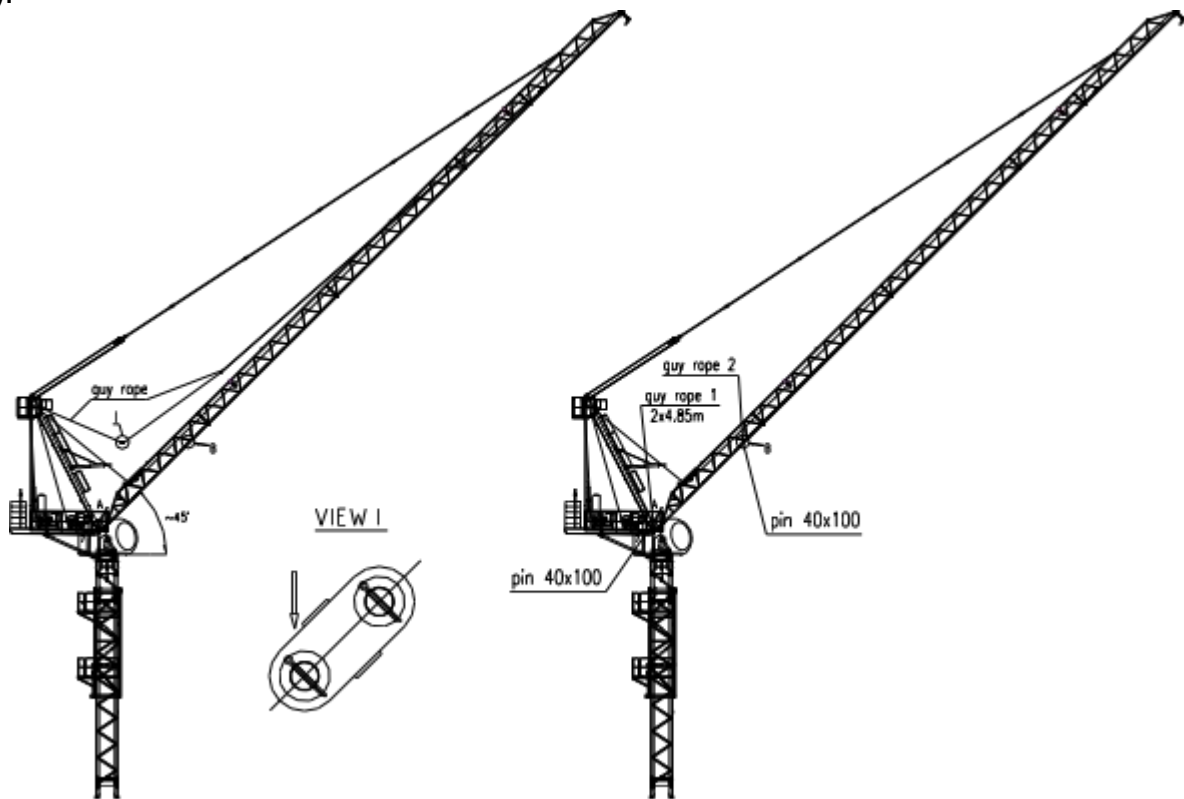

Drawing 13

4.3.14 Adjustment of safety devices

4.4 Assembling the telescopic cage

General notes

- The telescoping assembly consists of main parts remaining on the crane and of a certain number of accessories used during telescoping only.
- For fitting the telescoping assembly, three cases are possible:
 - Fitting of the complete assembly during normal erection of the crane
 - Partial fitting for increase in height
 - Partial fitting for dismantling the crane
- The following pages describe the fitting of the telescoping assembly after normal erection of the crane.

Fitting out the telescopic cage

- Fitting out the telescopic cage is carried out with the cage in horizontal position; if the telescopic cage must be put in upright position, it has to be anchored by guy ropes.

- For assembling the main parts of the telescoping equipment, refer to the corresponding detailed spare parts brochure.
- In order to fit the parts making up the telescoping assembly, see this section.

□ **General instructions**

- The slewing crane part must be balanced compulsorily when the telescoping assembly is lifted or being lifted and during the introduction of a mast section.

Jib length (m)	25	30	35	40
Balance weight (t)	1.20	0.50	0	0
Distance D (m)	25	30	35	40
Jib angle α°	30°	30°	30°	45°

- The wind speed is limited to 60 km/h.
- It is forbidden:
 - to slew the jib,
 - to operate the hoist winch (Hoisting or Lowering) when the telescoping assembly is lifted or being lifted,
 - to move the trolley(s) when the telescoping assembly is lifted or being lifted,
 - to keep the telescoping assembly resting on the cylinder.
- Use of the safety pins when telescoping:
 - The telescopic cage is equipped with 4 pins of which the diameter has been reduced by 2 mm in order to make their fitting easier.
 - These pins, connected to the telescopic cage by means of a chain, are **ONLY TO BE USED FOR TELESCOPING**. They ensure the connection between the fixed tower head or connecting mast and the last telescoped mast section on each mast level.
 - They must be fitted on the lateral sides.
 - At the end of telescoping and before disconnecting telescopic cage/fixed tower head or connecting mast and lowering the telescopic cage, they must be replaced by the normal mast shafts.
 - IT IS STRICTLY FORBIDDEN TO CARRY OUT ANY HOISTING OPERATION BEFORE PLAC-ING THE NORMAL WORKING SHAFTS.**
- Interruption of telescoping:

-The last mast section must be pin-connected to the crane tower with the normal shafts.

-The tower head or the connecting mast must be pin-connected to the last mast section of the crane tower with the normal working shafts.

-The balancing load must be laid down.

-There is no mast section hanging from the monorail trolley. The latter must be lowered to the ground.

-The pulley block must be raised under the trolley.

-Move the trolley away enough so that the pulley block cannot get caught by the monorail(s) when the crane is weather-vaneing.

-Observe the conditions for keeping the telescopic cage at the top of the mast

-For SHIFT END, observe the instructions given in the OPERATING INSTRUCTIONS.

Handling the telescopic cage

The weight of the equipped telescopic cage may exceed the maximum load permitted for the crane. For handling the telescopic cage, reduce its equipment so that this maximum load is not exceeded.

FITTING THE TELESCOPIC CAGE BY SELF-MOUNTING

-This operation can only be carried out with a crane the maximum load of which exceeds the weight of the package to be handled.

LOWERING THE TELESCOPIC CAGE BY MEANS OF THE HOOK

-This operation can only be carried out with a crane the maximum load of which exceeds the weight of the complete telescopic cage.

-FOR CRANES WHOSE MAXIMUM LOAD IS INFERIOR, it is possible to lay down the hydraulic unit, the hydraulic cylinder and the telescoping yoke in order to reduce the weight of the assembly to be handled without exceeding the maximum load of the crane.

-If, despite of removing the accessories, the weight is higher than the maximum load of the crane, THE TELESCOPIC CAGE MUST COMPULSORILY BE LOWERED AGAIN BY MEANS OF THE HYDRAULIC CYLINDER.

4.4.1 Fitting the hydraulic unit and cylinder

-Install the hydraulic unit (1) onto the rear platform (2).

-Introduce the cylinder (3) into the through hole (4) of the lower telescopic cage frame (piston rod down-ward).

- Pin-connect the cylinder (3) with the telescopic cage gussets using shaft (5).
- Connect the pipes (6) to the hydraulic unit (1) – See Operating Instructions.
- Fill the hydraulic unit with oil, carry out the electrical connections and bleed the hydraulic circuits by operating the cylinder without load as shown in the Operating Instructions. Then top up the hydraulic unit.
- Fit the telescoping yoke (7) onto the lugs of the basic mast and extend the cylinder in order to pin into the yoke fork by means of shaft (8); then fix with split-pin.

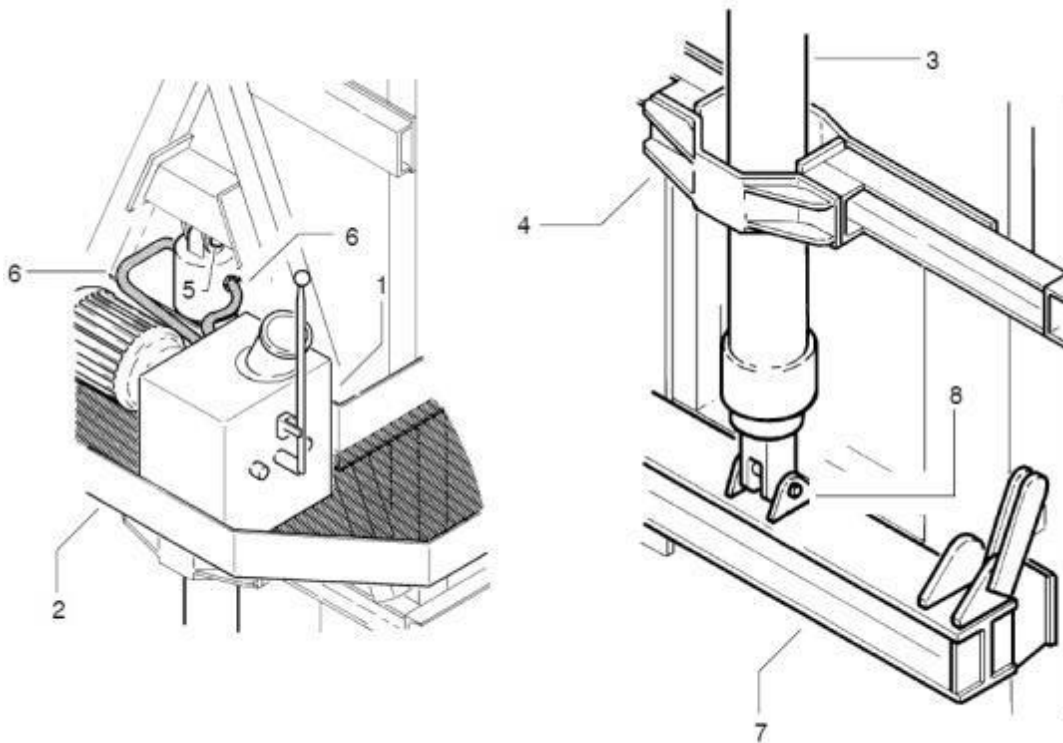

Figure 1

4.4.2 Fitting the accessories

4.4.2.1 FITTING THE MONORAIL

The monorail is fitted onto the telescoping mast. This operation can be carried out:

- In the air, before telescoping or telescoping down.
- On the ground, before fitting the connecting mast.

FITTING THE MONORAIL IN THE AIR

Fitting the monorail is carried out by means of the telescoping hook.

- Fit the plates (1) by means of the shafts (2) onto the gussets (3) of the telescoping mast. Fit the shafts (4) onto the plates (1) (Figure 1 – Detail A).

-Using the telescoping hook (5), pick up the monorail (6) by the round bar (7) (Detail B – Figure 1) and fix a cord on the other end.

-Lift until the cord can be taken; for this, use the telescoping grab.

-Using the cord, raise and pin-connect the monorail to the plates (1) by means of the Shaft (4) (Detail C – D – E – Figure 1).

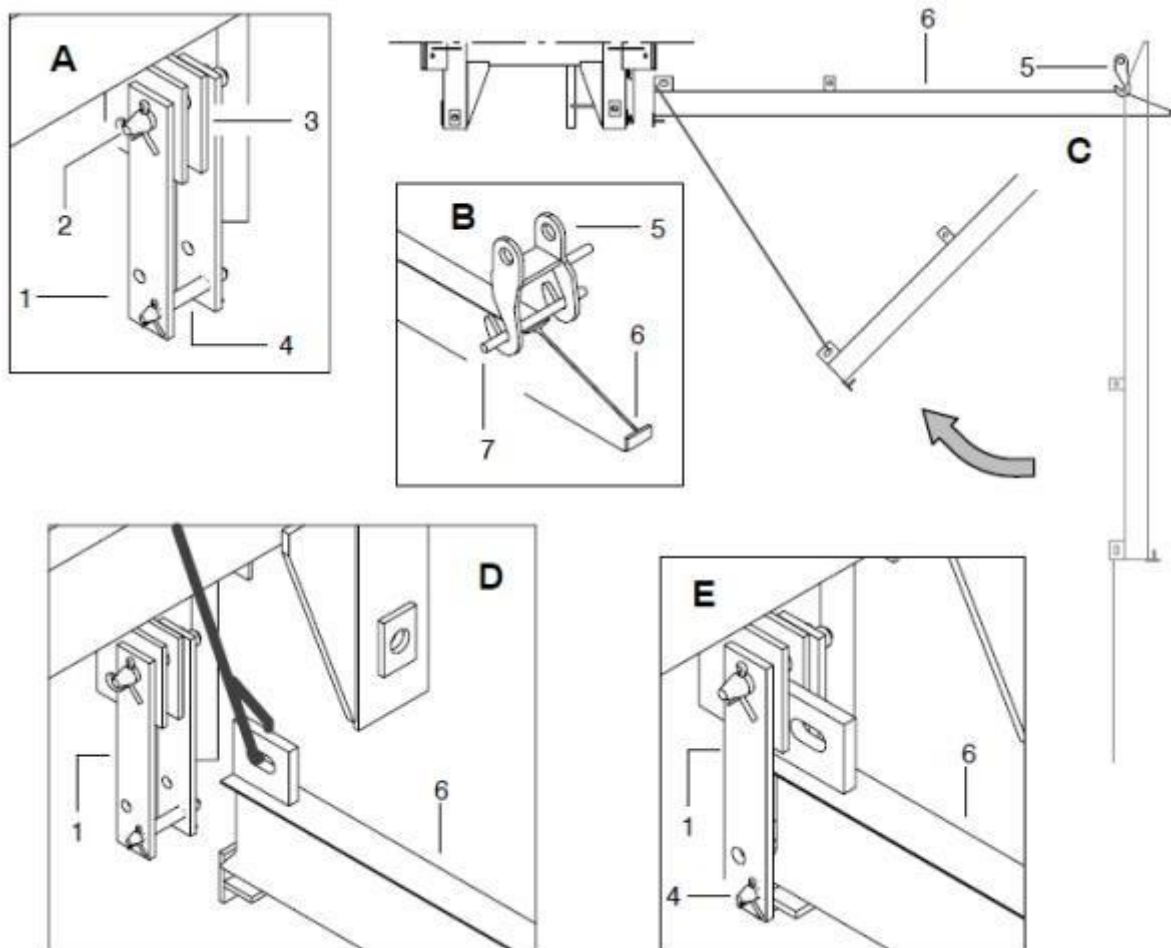

Figure 1

-Operate "Trolley in" until the monorail (6) can be pinned to the gussets (8) by means of the shaft (9)(Detail A – Figure 2), then to the gussets (3) by means of the shaft (10) (Detail B – Figure 2).

-Remove the shaft (4), then raise the plates (1) and refit the shaft (4) as well as the shaft (11) (Detail C – Figure 2).

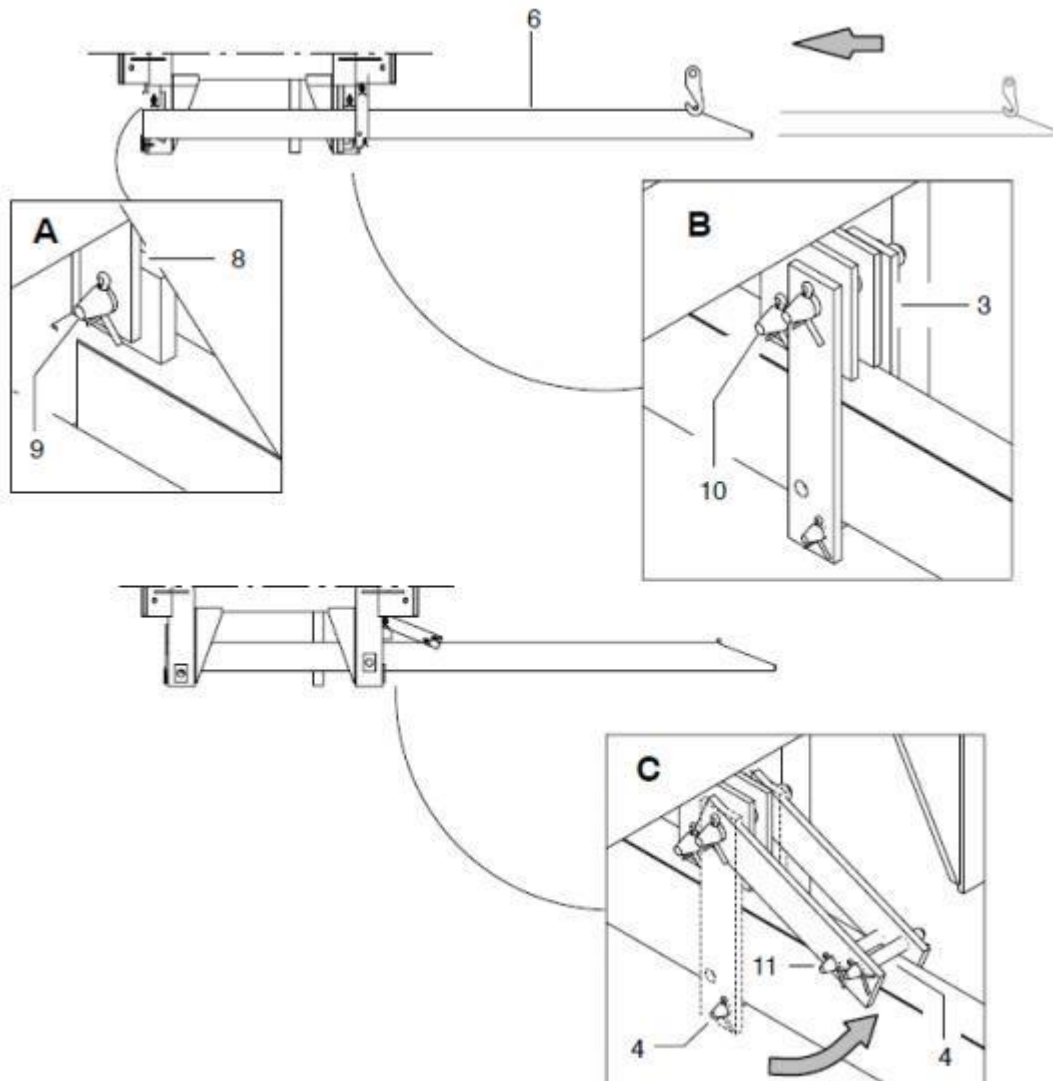

Figure 2

□ FITTING THE MONORAIL ON THE GROUND

-The fitting operations are identical with those of fitting in the air, on the other hand, handling of the monorail will be carried out by means of the mobile crane and a sling instead of the telescoping hook.

4.4.3 Balancing for telescoping

4.4.3.1 GENERAL INSTRUCTIONS

Balancing for telescoping is carried out in two phases:

- Theoretical, by hanging a load at a given radius.
- Practical, by adjusting the position of the jib angle

We remind that it is strictly forbidden to **SLEW the jib**

to MOVE the jib

to OPERATE the hoist winch (hoisting or lowering) when the telescoping assembly is lifted or being lifted.

4.4.3.2 PARTICULAR INSTRUCTIONS

The good working order of the telescoping assembly (cylinder and telescopic cage) needs that the center of gravity of the lifted crane part is located in the cylinder axis. Make sure too, that one mast section is hanging from the monorails before proceeding balancing.

Move the jib, possibly with an appropriated load, to the balancing position given in the table.

The indicated distances are theoretical; they especially depend on the actual weight of the counter-jib ballast. Make sure that this ballast weight corresponds to the used lengths of counter-jib and jib.

Furthermore, the wind has a considerable action on the crane balance, telescoping is no longer allowed beyond 60 km/h.

4.4.4 Principle

The telescoping sequence comprises a series of operations which are repeated several times:

- Fit the monorail trolley (1) onto a mast section (2) chosen according to the mast composition.
- Hang the monorail trolley (1) from the telescoping hook (3), raise the assembly and hook the trolley(1) to the monorail (4) making sure that the telescoping lugs of the mast are located on the crane side (Figure 1).
- Free the telescoping hook and suspend the balancing load .
 - The crane is in balancing position.
 - Shut the telescopic cage locks (Detail A – Figure 2).
 - Remove the shafts connecting the basic mast to the connecting mast for telescoping.
 - Operate the lever of the hydraulic unit in the “up” direction. Slowly telescope until

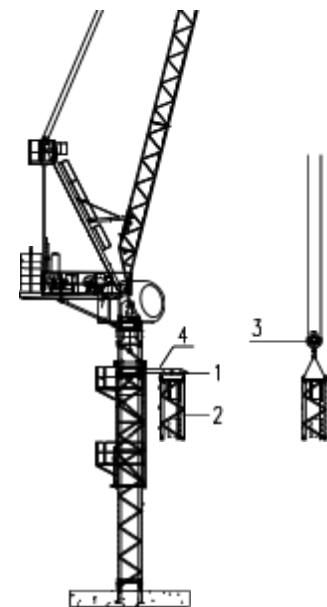

the telescoping connecting mast feet just leave the fishplates of the basic mast (Detail B – Figure 2).

-If required, readjust the balancing given in paragraph (4-assembly) by manoeuvring the jib. The exact balancing position is found by verifying the alignment of the telescopic connecting mast feet with the basic mast fishplates and checked by reading the minimum pressure required for telescoping on the pressure gauge of the hydraulic unit. After balancing, open the locks (Detail C – Figure 2).

-Telescope until the telescopic cage pawls (5), kept away from the mast, are above the lugs (d) of the basic mast (Detail D – Figure 2).

-Slowly operate the hydraulic unit lever in "down" direction in order to rest the pawls (5) onto the lugs(d) (Detail D – Figure 2).

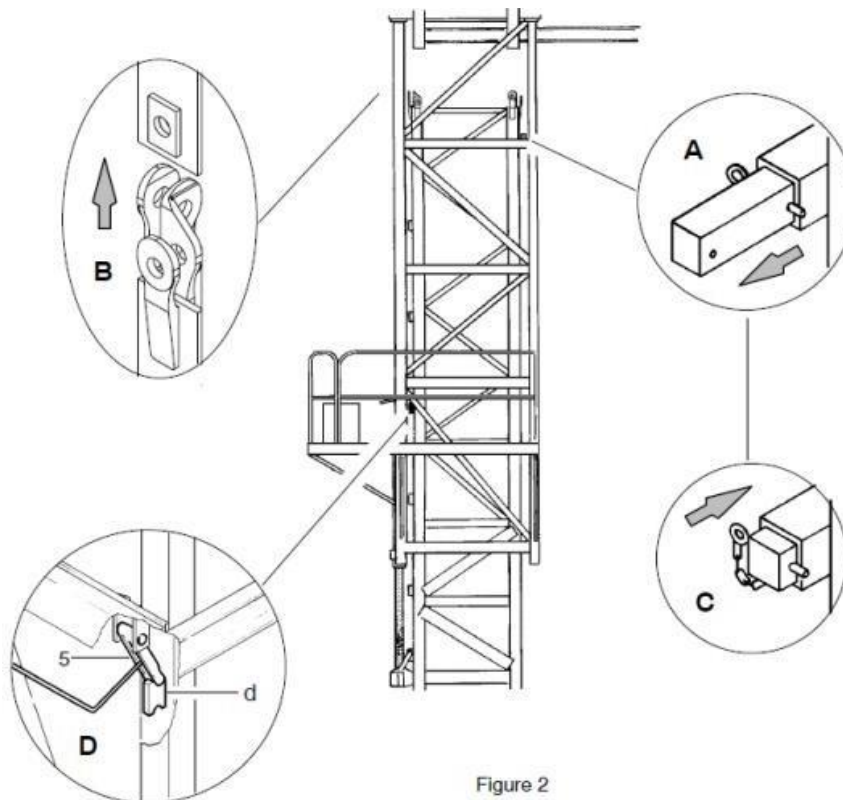

Figure 2

-After resting the telescopic cage by means of its pawls onto the lugs (d), pull the hydraulic unit lever in the "down" direction, the yoke (6) rises and hangs up onto the next lugs (b) above (Detail A – Figure3).

-Operate the hydraulic unit lever in the "up" direction, the cylinder extends and the pawls (5), resting on the lugs (d), rise to the lugs (e) (Detail B – Figure 3).

-Operate the lever in the "down" direction in order to rest the pawls (5) onto the lugs (e) (Detail B – Figure3).

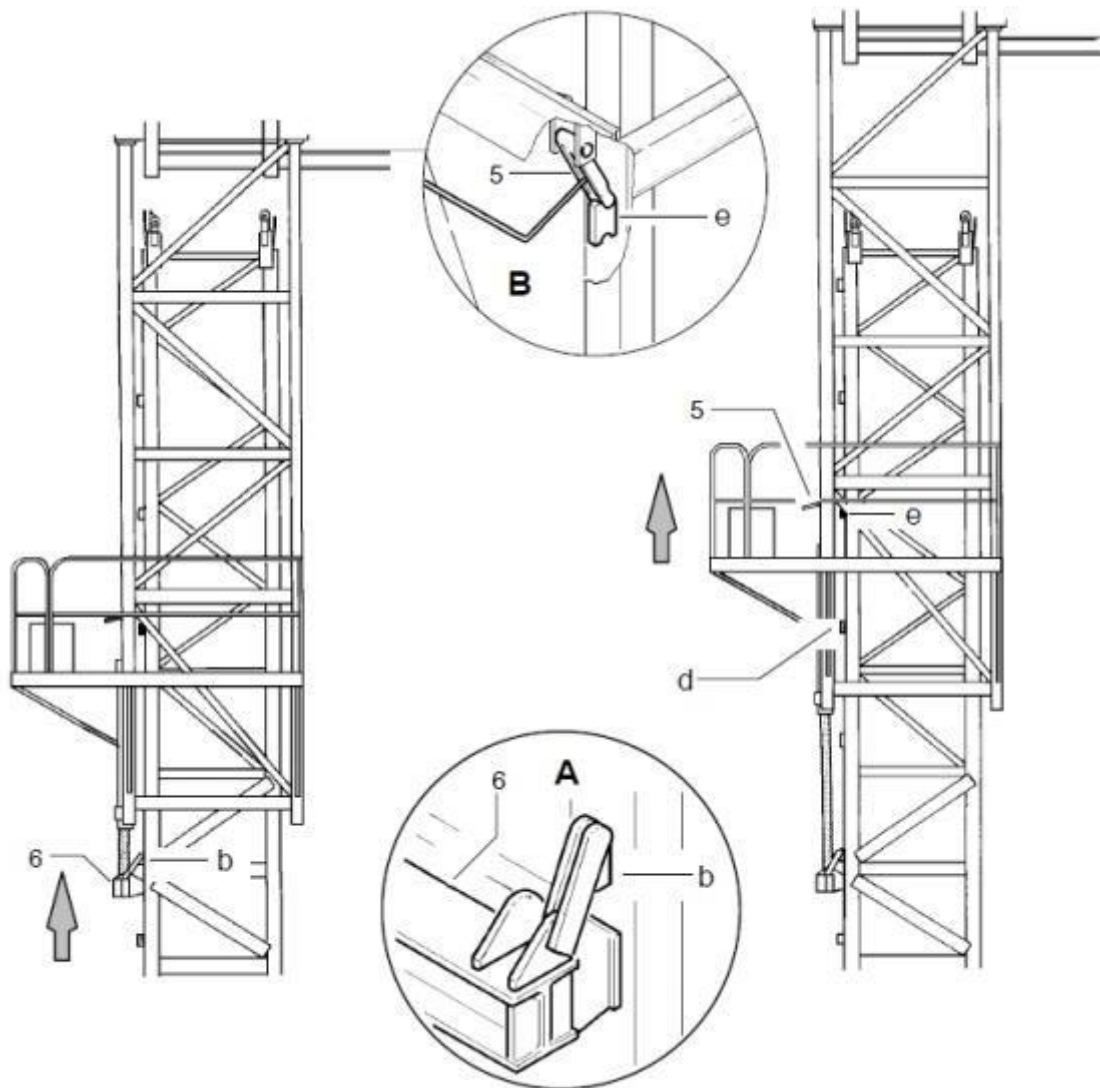

Figure 3

-After resting the telescopic cage by means of its pawls onto lugs(e), pull the hydraulic unit lever in the "down" direction, the yoke (6) rises and hangs up onto the lugs (c)(Detail A - Figure 4).

-Then push the lever in the "up" direction, the telescopic cage rises and the pawls which are resting up to now on the lugs (e) come to rest onto the next lugs (f) above (Detail B - Figure 4).

-From that moment, operate the hydraulic unit lever in the "down" direction, the cylinder retracts, the yoke (6) leaves the lugs (c) in order to come to hang up onto the next lugs (d) above.

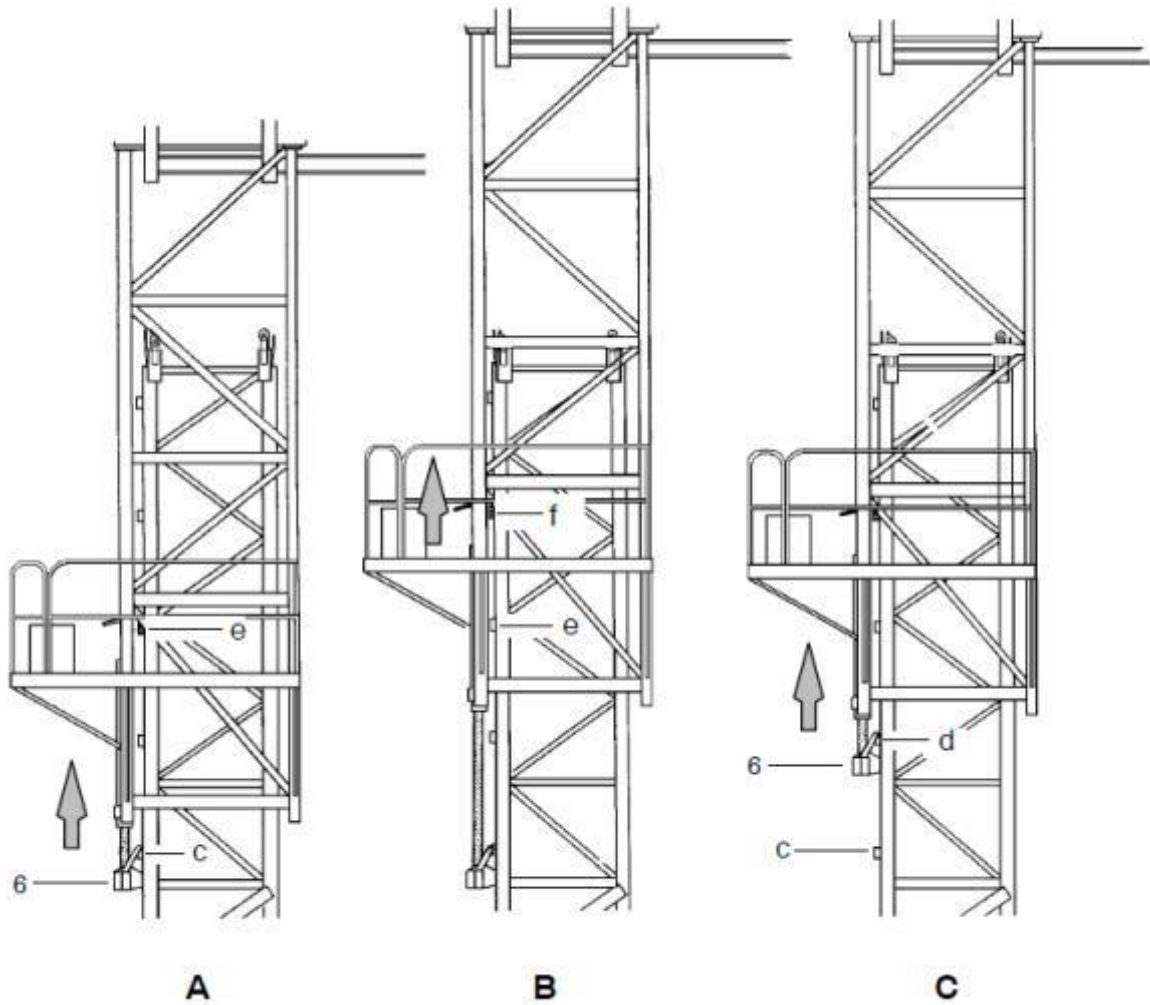

Figure 4

-After hooking the telescoping yoke onto lugs (d), push the hydraulic unit lever in the "up" direction in order to allow the pawls to be supported on lugs (g) without however enabling the telescopic cage rollers to come out (Detail A - Figure 5).

-Do not raise the yoke onto the next lugs above.

-The crane is now in the required position for introducing the mast section into the telescopic cage.

-Introduce the mast section (2) into the telescopic cage using a grab provided for this purpose (Detail B - Figure 5).

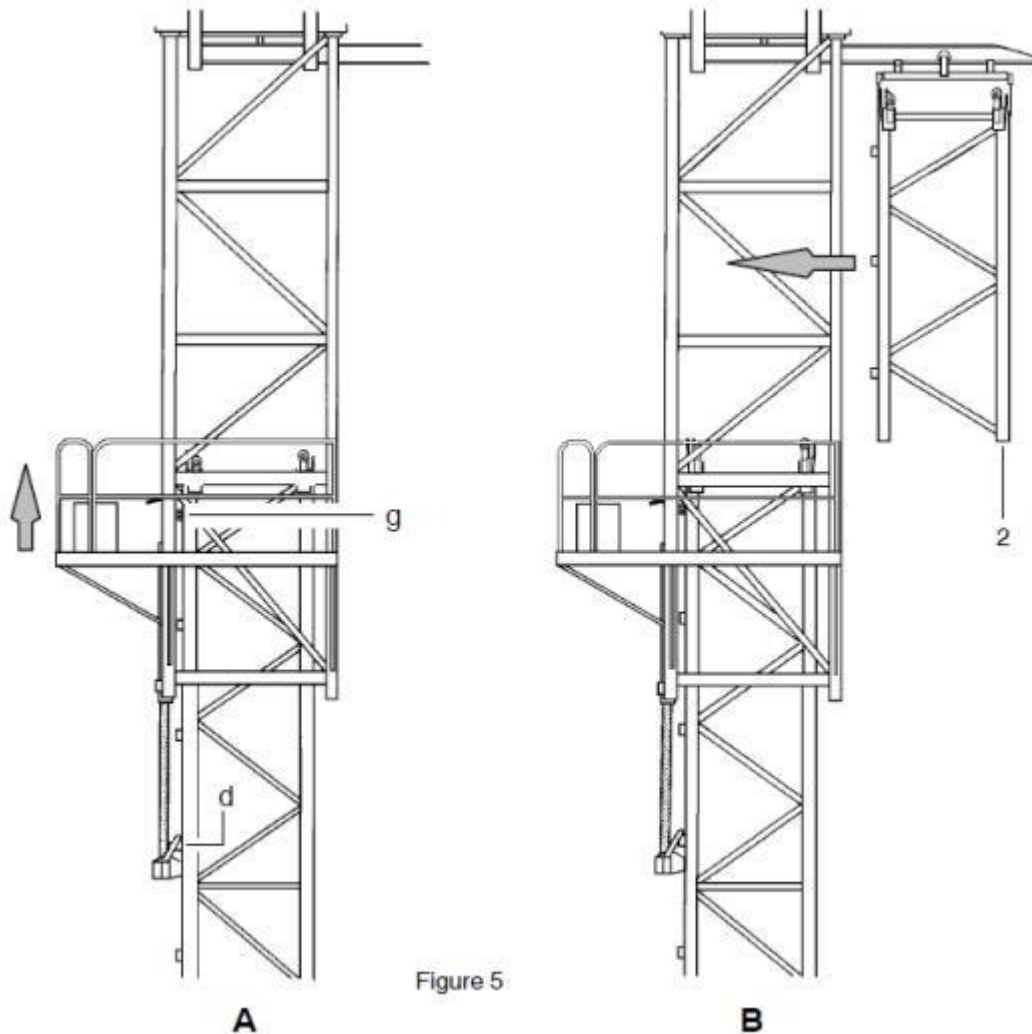
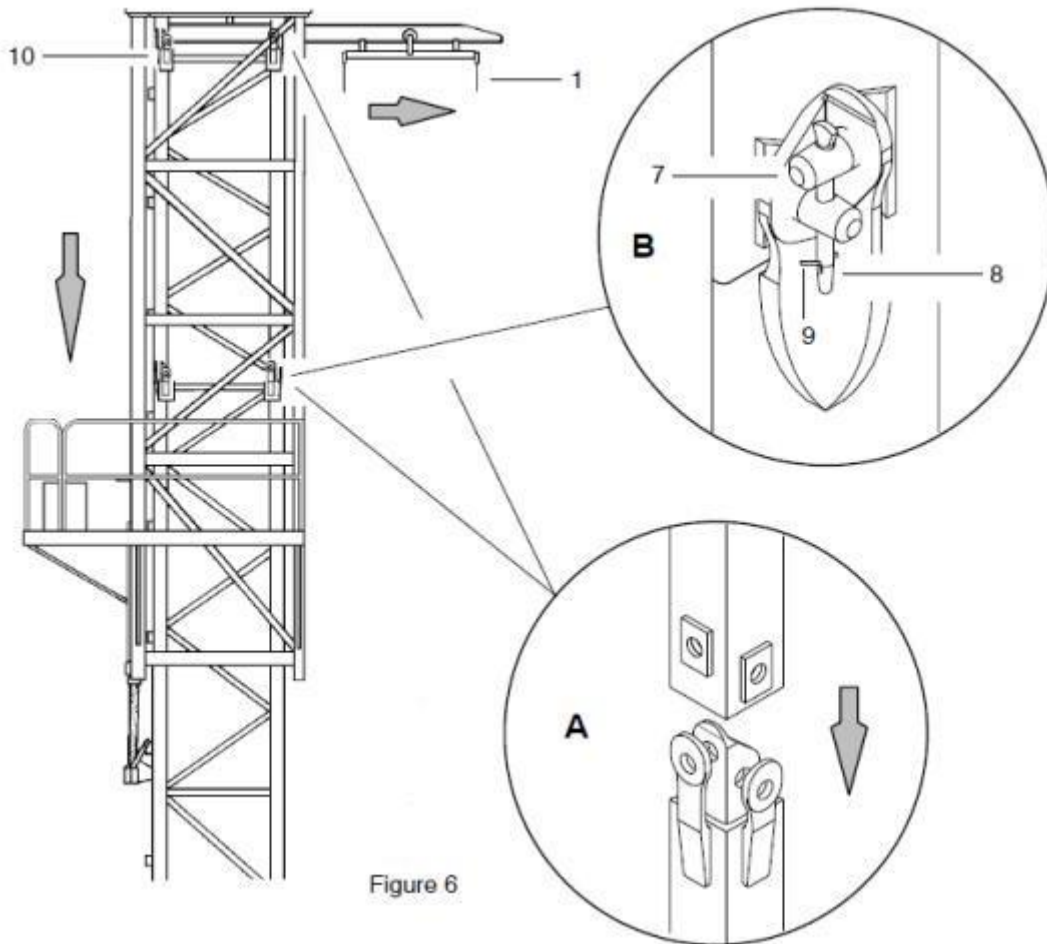

Figure 5

- Having introduced the mast section into the telescopic cage, pull slightly the hydraulic unit lever in the "up" direction in order to free the pawls of the telescopic cage from the mast lugs.
- Maintain the pawls far from the masts and operate the hydraulic unit lever in "down" direction.
- Make sure that the mast section engages properly into the fishplates of the basic mast (Detail A - Figure 6); pin-connect by means of 4 x 2 shafts (7), 1 pin (8) and 1 safety pin (9) (Detail B - Figure 6).
- Continue lowering and make sure that the telescoping mast engages properly into the fishplates of the mast fitted before (Detail A - Figure 6); pin-connect at (10) by means of 4 safety shafts.
- Free the monorail trolley (1) from the mast section and bring it out onto the monorail.
- Lower and place the balancing load on the ground in order to free the telescoping hook.
- Using the telescoping hook, lower the monorail trolley in order to fit it, if required, onto a new mast section.

- Repeat this telescoping procedure as often as necessary to reach the desired height.
- At each first cylinder stroke, do not forget to remove the safety pins linking the telescopic connecting mast to the masts.
- THE LAST MAST SECTION MUST BE FIXED: TO THE MAST ON THE ONE HAND TO THE TOWERHEAD FEET ON THE OTHER HAND



4.4.5 Folding down the monorail

- In order not to hinder the trolley manoeuvring at minimum radius, it is necessary to fold down the monorail alongside the crane tower.
- Equip the pulley block with the telescoping hook if it had been removed, take off the shafts (a) and (b) of the monorail support plates (1) (Detail A - Figure 1).
- Fold down the plates (1) in vertical position and pin shaft (a) (Detail B - Figure 1).
- Hook up the monorail at the round bar (2).
- Unpin shafts (c) and (d) (Detail C - Figure 1).
- Operate "Trolley out" until the monorail is hooked on to shaft (a).
- Insert shaft (b) (Detail D - Figure 1).

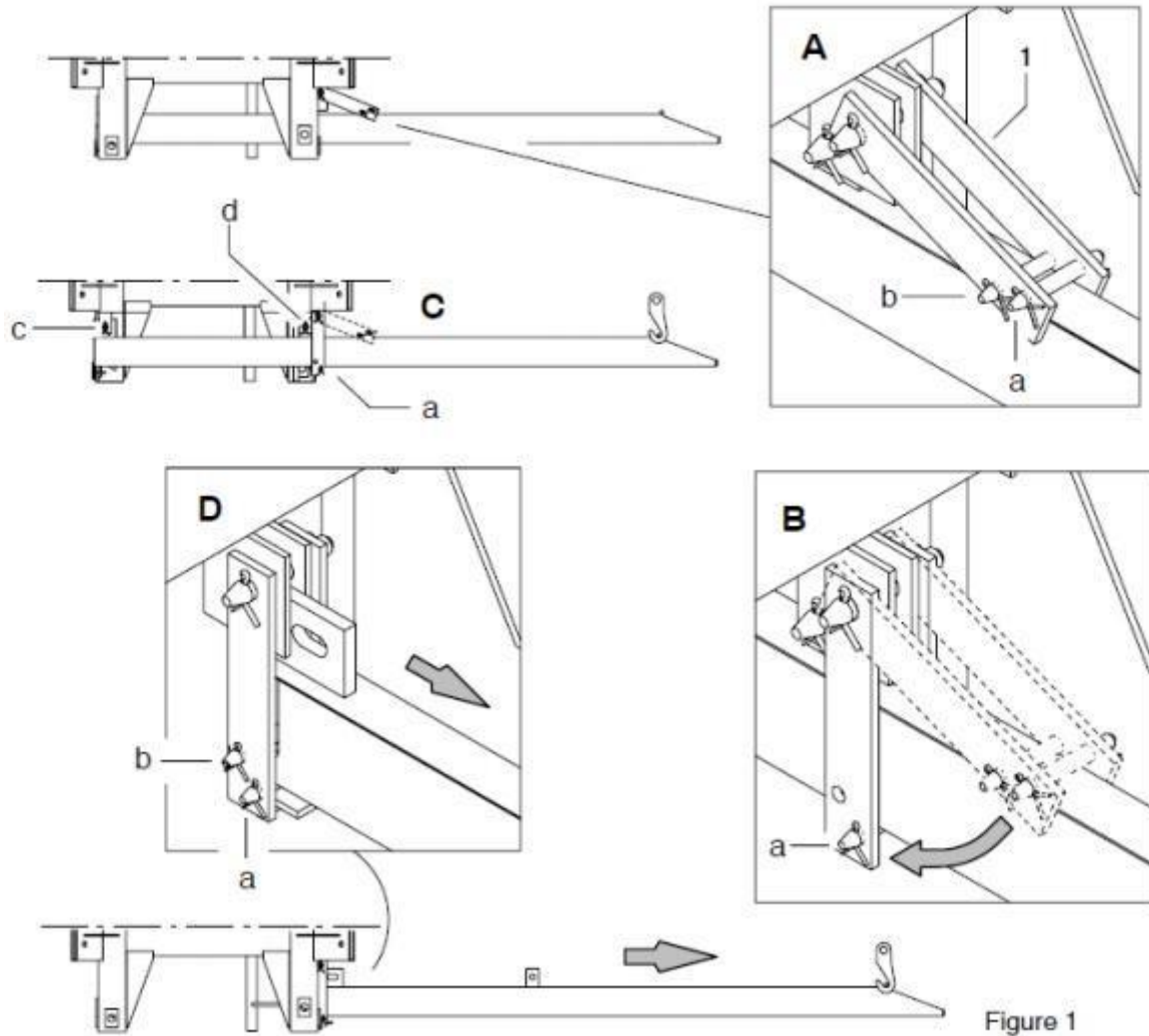

-Lower the pulley block, the monorail folds down alongside the mast, free the hook (Detail A - Figure2).

NOTE: When the monorail is to be completely dismantled for use on another machine, continue the operations from the moment of hooking up the monorail at the round bar (2) (Detail B - Figure 2).

-Fasten the monorail on the crane side by means of a cord.

-Remove shaft (a) (Detail C - Figure 2).

-Slacken the cord and lower slowly (Detail D - Figure 2).

-Using the crane, lower and place the monorail on the ground.

-Take off the monorail support plates (1) and the shafts (a-b-c-d-e) which will be reused.

-Remove the telescoping hook and equip the pulley block with the standard hook.

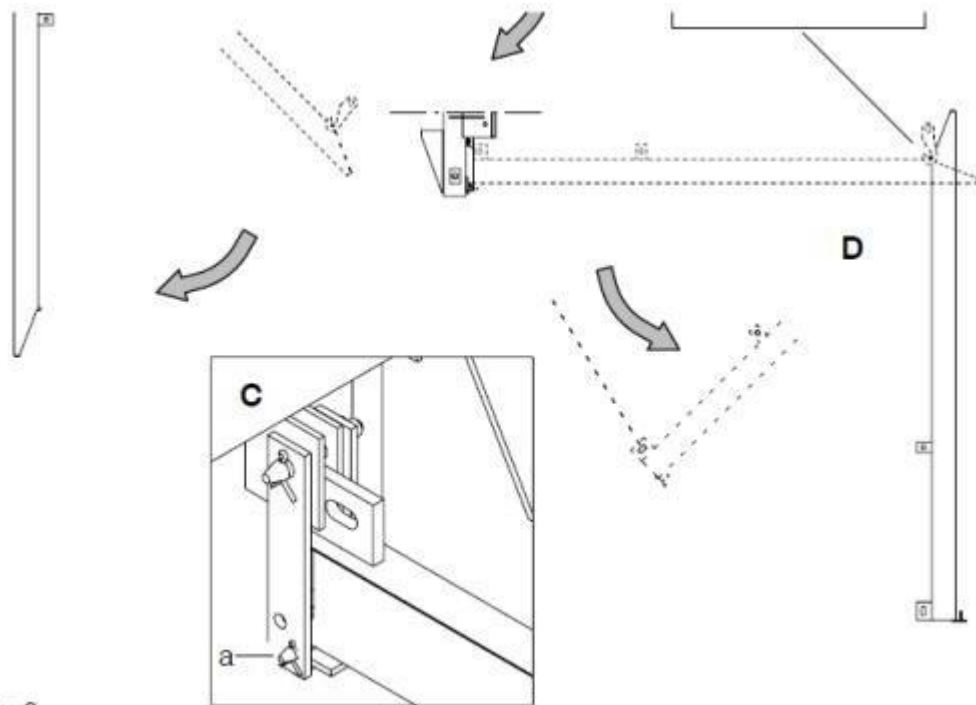

Figure 2

4.4.6 Lowering the telescopic cage

- Using the crane, lower the telescoping yoke and the cylinder to the ground.
- Sling the telescopic cage at the cylinder support beam (Detail A – Figure 1) and hook it on the load hook. Use a sling of sufficient length. -Tighten the sling but not too much.
- Check that the mast sections are pinned together and linked to the telescoping mast.
- Remove the shafts (1) connecting the telescopic cage to the telescoping mast.
- Release the safety locks.
- In order to carry out the lowering operation in safety, the personnel does not remain on the cage, but works from inside the mast using the normal accesses.
- Slacken the rope, the cage must lower by its deadweight.

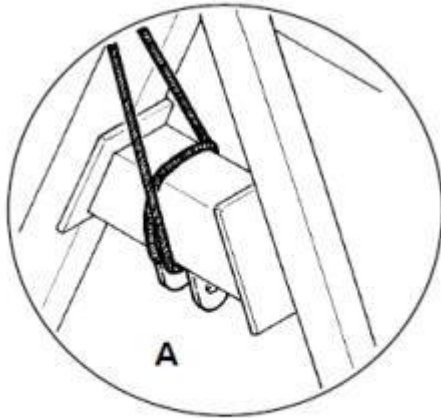
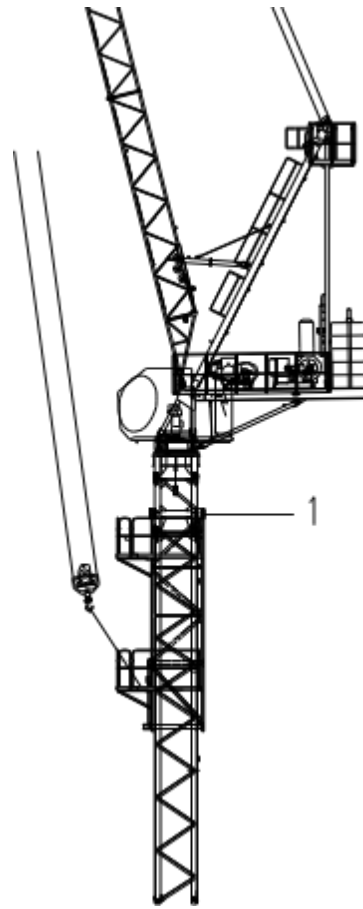

Figure 1

**Caution:**

- During this operation, counterbalance as much as possible the lateral forces due to the sling tension so as to prevent the telescopic cage from getting blocked on the mast. The weight of the hydraulic unit contributes to this balance.
- Release the safety locks at each passage over the lugs and continue lowering the telescopic cage until it reaches the lowest position on the basic mast (Figure 2).
- Rest the telescopic cage onto a set of lugs or onto planks if the mast section is not equipped with lugs.
- Remove the hydraulic unit and store it away with the cylinder and the telescoping yoke.

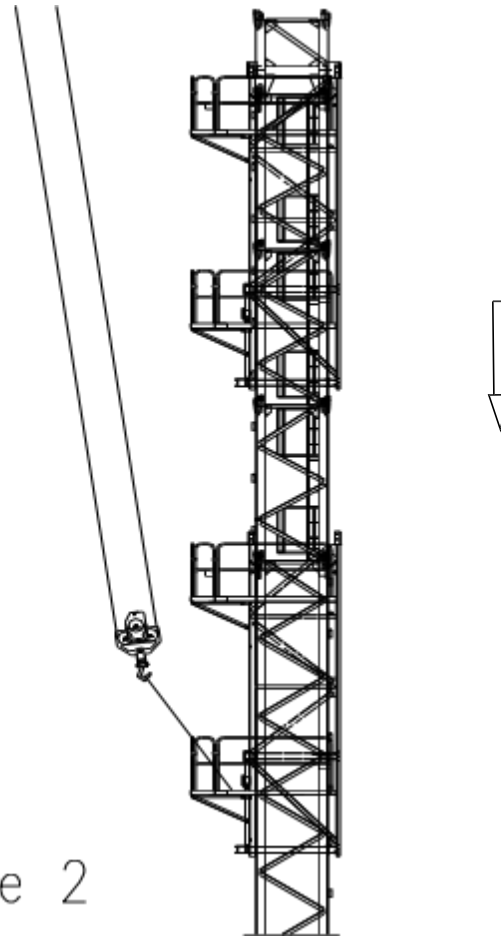

Figure 2

4.5 Anchorage frame 1.2m

4.5.1 Dimensions and weights

The dimensions and weights given in the tables on the following pages correspond to:

- The first line of each group indicates the dimensions and the weight of the component assembled with the parts as they are shown in the drawing.
- The following lines indicate the dimensions and weights of the main parts according to representation.
- The direction of dimensions L, l and h with respect to the mark concerns the main parts only.

Important: The sum of the weights of the main parts is lower than the weight of the equipped component because the weight of pins, bolts, small accessories, etc. is not taken into account.

4.5.2 Dimension and weight of the anchorage frame 1.2m

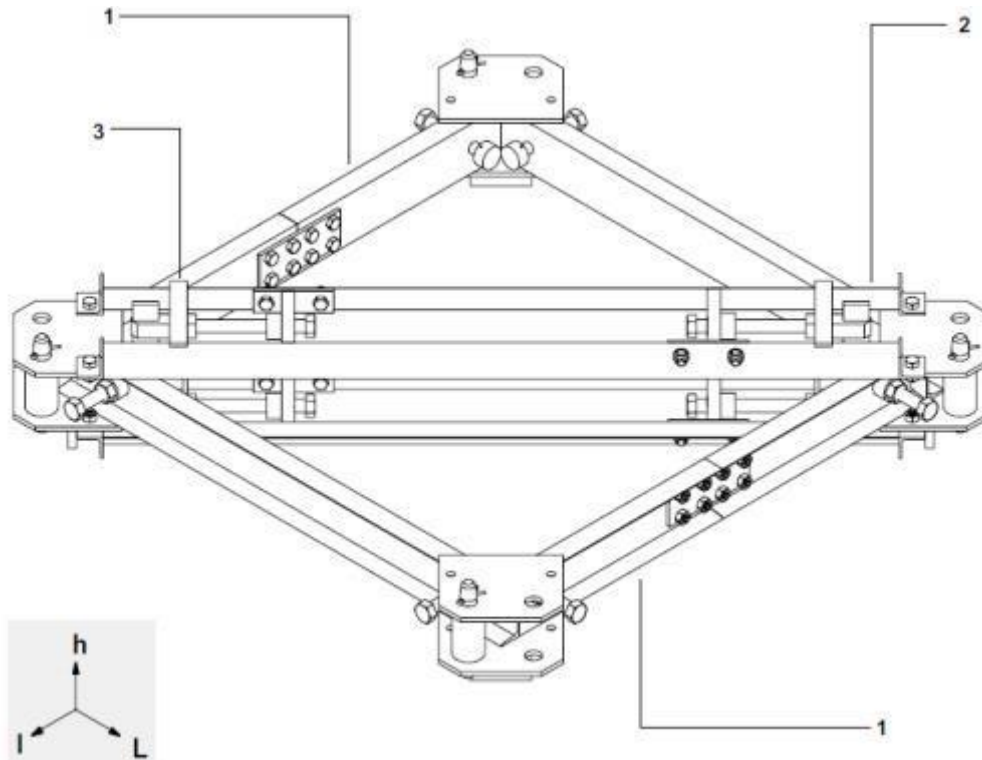

No.	Quantity	Designation	L	i	h	P (kg)
	1	Anchorage frame 1.2m	1715	1715	265	1415
1	2	Half anchorage frame1.2m	1700	850	280	647
2	4	Diagonal bracing	1950	275	60	14
3	4	Tightening stop + screw				6.5

4.5.3 Anchorage

4.5.3.1 General notes

Beyond the free standing height of rail-mounted or static crane, the crane must be connected either to the ground by anchorage by guy ropes or to the building by rigid anchorages.

For each utilization of anchorages on cranes with chassis, please consult us.

The present brochure deals only with the rigid anchorages to the building. For anchorages by guy ropes please consult our After-Sales-Service. In addition, the device is described in another brochure.

The mast compositions, the position of the anchorages as well as the loads applied on the frames are indicated in the chapter 2.

4.5.3.2 General instructions

Positioning the crane:

-When it is a crane on rail-mounted chassis, move it in its static position, tighten the rail clamps and disconnect the traveling gear. Consult us in order to know the special conditions for this installation.

-In certain cases it is necessary to telescope an additional mast section so that the anchorage frame can be fitted.

Important:

-Under these conditions the crane is no longer normally autonomous, and it is forbidden to work and to let the crane free out of service.

-When telescoping check the perpendicularity of the crane in both planes in order to avoid any variation of distance between crane tower and building.

4.5.4 Description and fitting frames

4.5.4.1 Description

□ A complete frame is composed of:

-2 unequipped half frames (1) and (2)

-These two half frames are linked together by means of 2x2 fishplates (3) which are fixed with 2 x 8 fishplate bolts H20 x 53 (4) (Detail A - Figure 1).

-4 bracings (5) linked together by means of 4 screw bolts HM 20x40 (6), and then bolted onto the half frames using 4 x 2 fishplate bolts H20 x 48 (7) (Detail B - Figure 1).

Each half frame has 4 holes (8) in order to allow the fixing of the connecting beams with the building. Fit the shafts 40 x 175L (9) and the spacers (10) on the half frames and fix them with split pins.

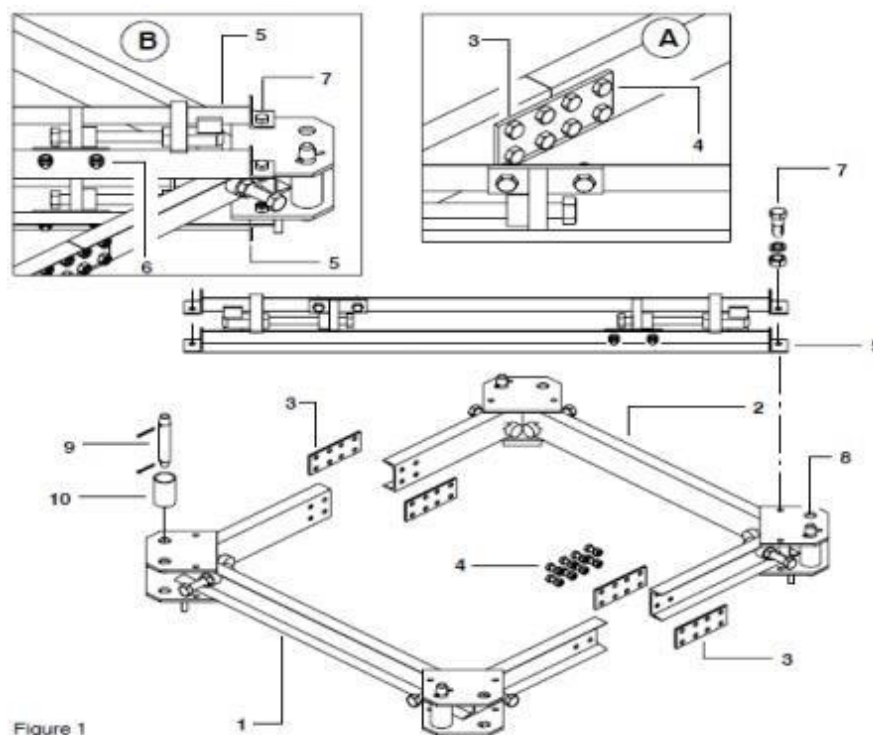

4.5.4.2 Main dimensions of anchorage frame 1.2m

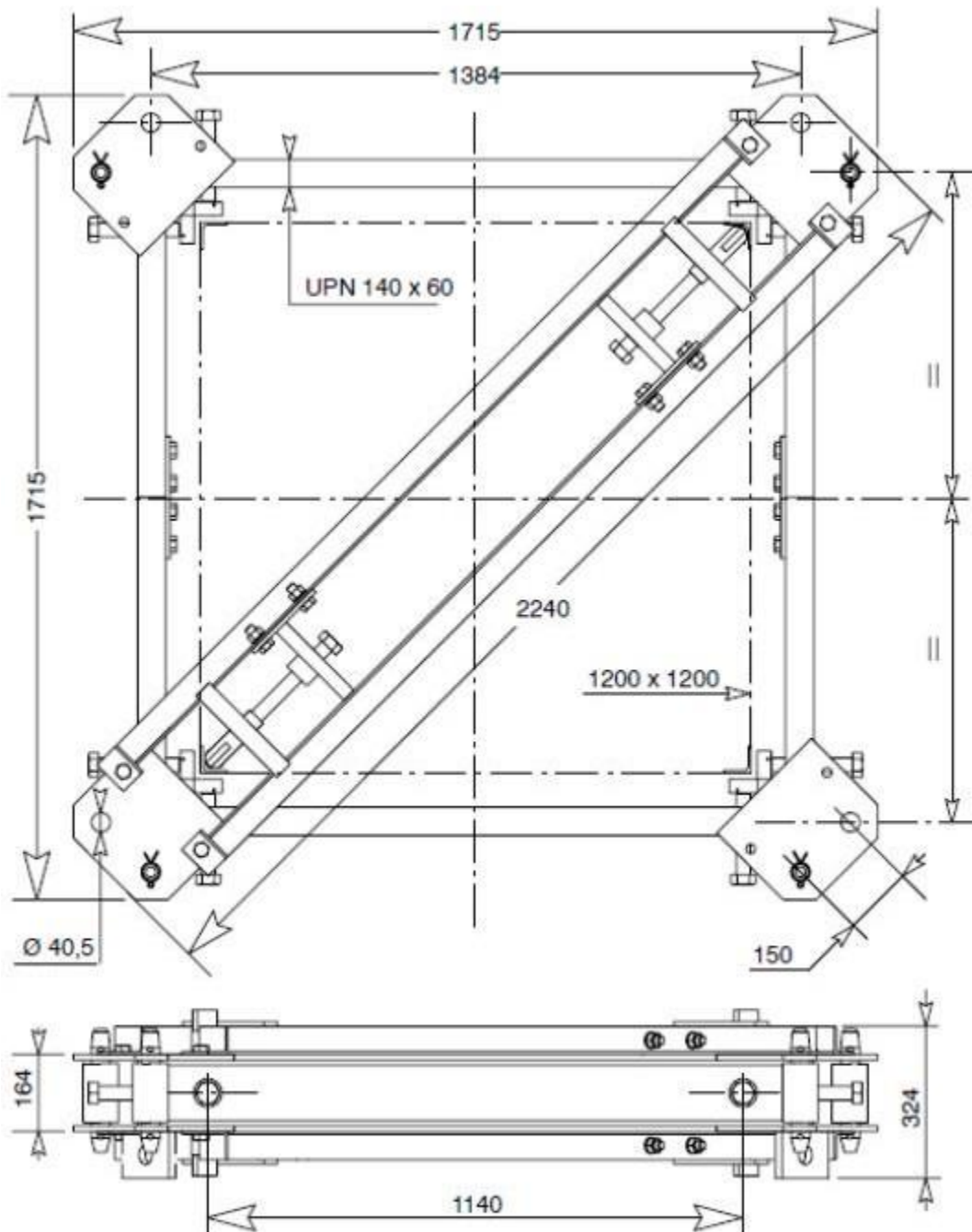

4.5.4.3 Different types of recommended rigid anchorages

 Anchorage to a building using a-frame and 2 ropes

-The A-frame can be constructed of 2 profiles channel or 2 symmetrical angle irons or, which is better, of 2 tubes or 2 reinforced symmetrical angle irons, avoiding the cross-bracing. The ropes arranged on either side of the A-frame should make angles between 30 and 60° with the wall. The ideal solution is to have 2 symmetrical angles 45° (Detail A - Figure 2).

- Anchorage to a building using an a-frame and a beam
 - The A-frame is the same as for the above solution. The beam which can be made of the same profiles as the A-frame, should be at the correct length in order to form an angle with the wall, which is neither too closed nor too open (Detail B – Figure 2).

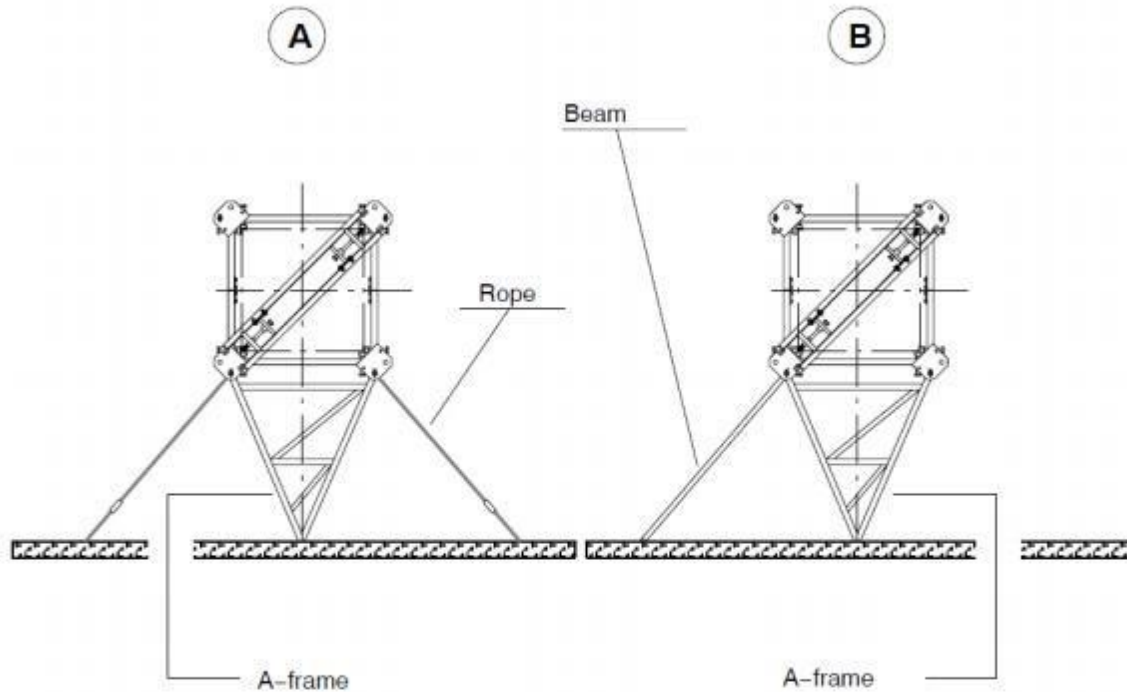

Figure 2

- Anchorage to a building using 3 beams
 - The requirements for fabrication of the parts and their arrangements are similar to those mentioned on the preceding page (Detail C – Figure 3).
- Anchorage to a building using 2 beams and 2 ropes
 - Beams: For details of construction, see above case.
 - Ropes: Fitted inside the beams, they complete a device which, if possible, should be arranged sym-metrically with respect to the axis of the crane (Detail D – Figure 3).

Note: When fitting the various anchorage devices, the beams and the ropes are connected to the crane by means of a frame which surrounds the mast. Tightening the rope is ensured by various models of tensions.

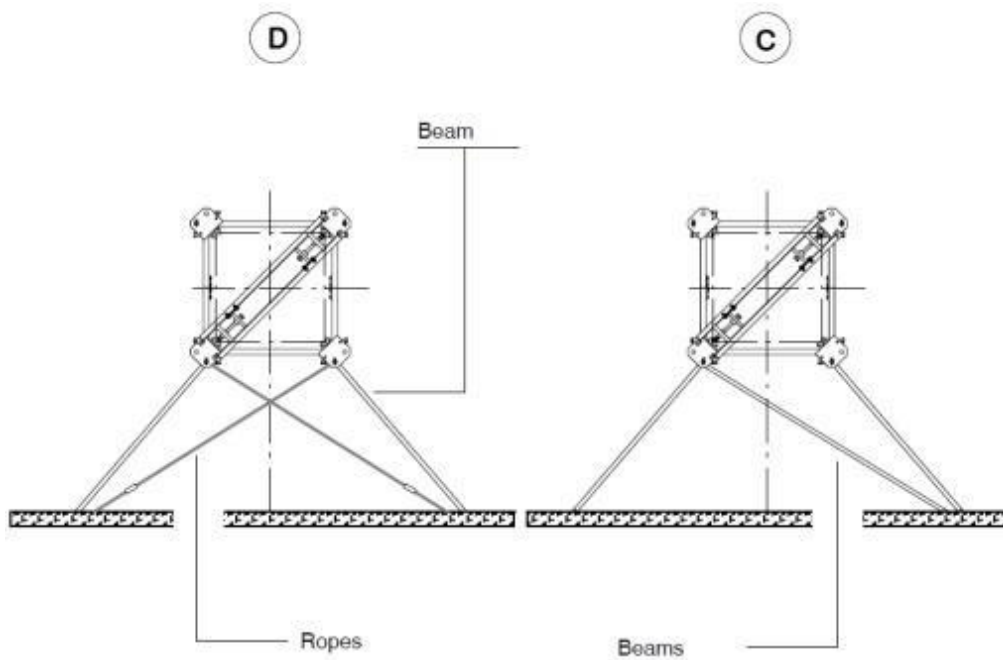

Figure 3

4.5.4.4 Fitting the frames onto the mast sections

- Fitting the frames onto the mast section is carried out as close as possible to the fishplates. In this position they allow taking up the loads given in chapter 2.

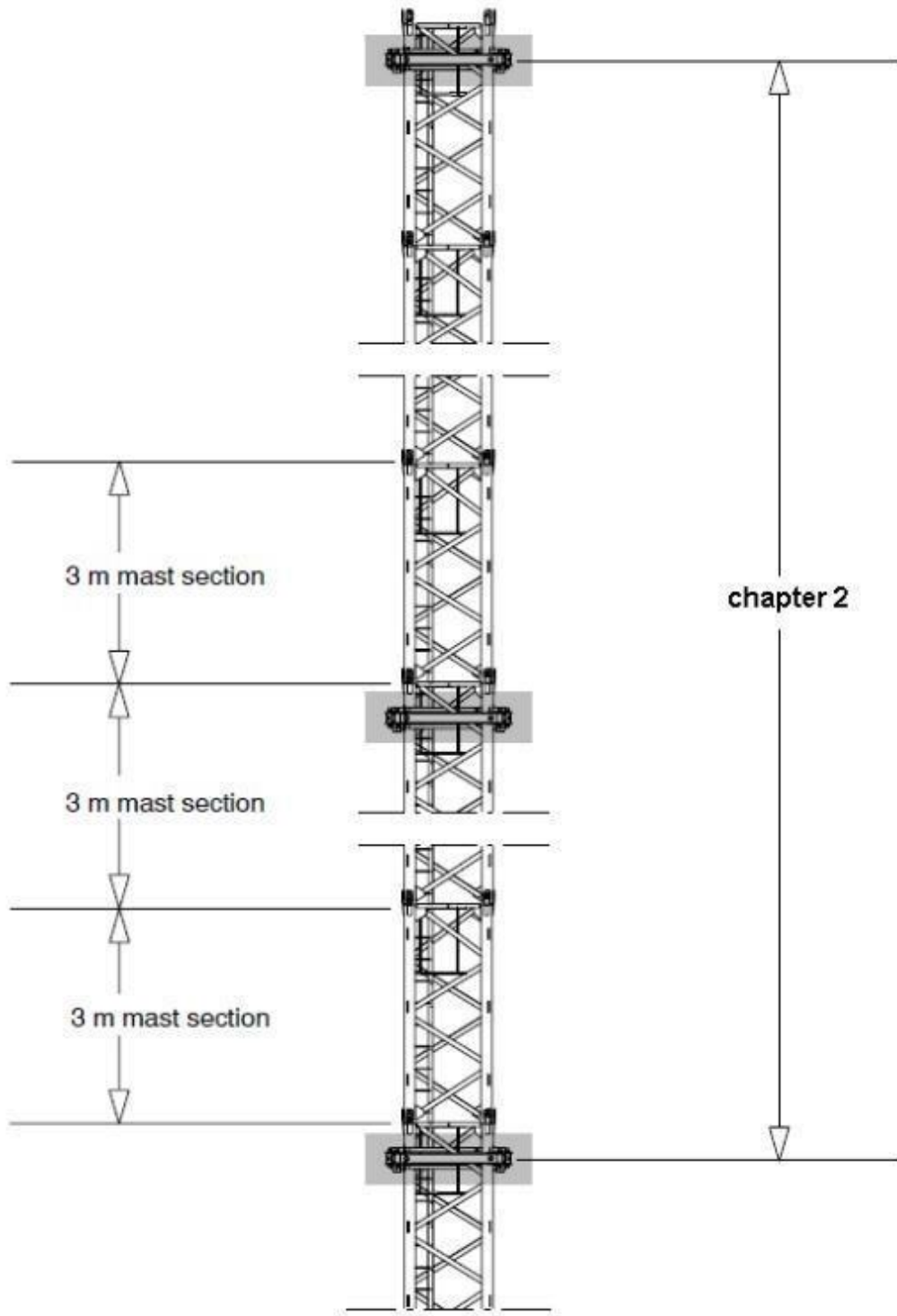

Figure 4

4.5.4.5 Fitting a frame

- Fix the half frame (1) by means of the slings (2) (Detail A – Figure 1).
- Raise the half frame and position it on the masts at right angle to its anchorage point. Maintain it in this position by means of the slings.
- Sling the second half frame (3), lift it, position it at the level of the first one connect them together by means of the 2x8 fishplates (4) and lock it by means of the 2x8 fishplate bolts H20x53 (5) (Detail B –Figure 1).
- As soon as the half frames are connected together, lock them onto the mast section by means of the blocking round bars (6) by operating the screws (7). The blocking round bars are locked on the screws (7) by means of the split pins (8) (Detail C – Figure 1). Maintain the half frame in the position by means of the slings.

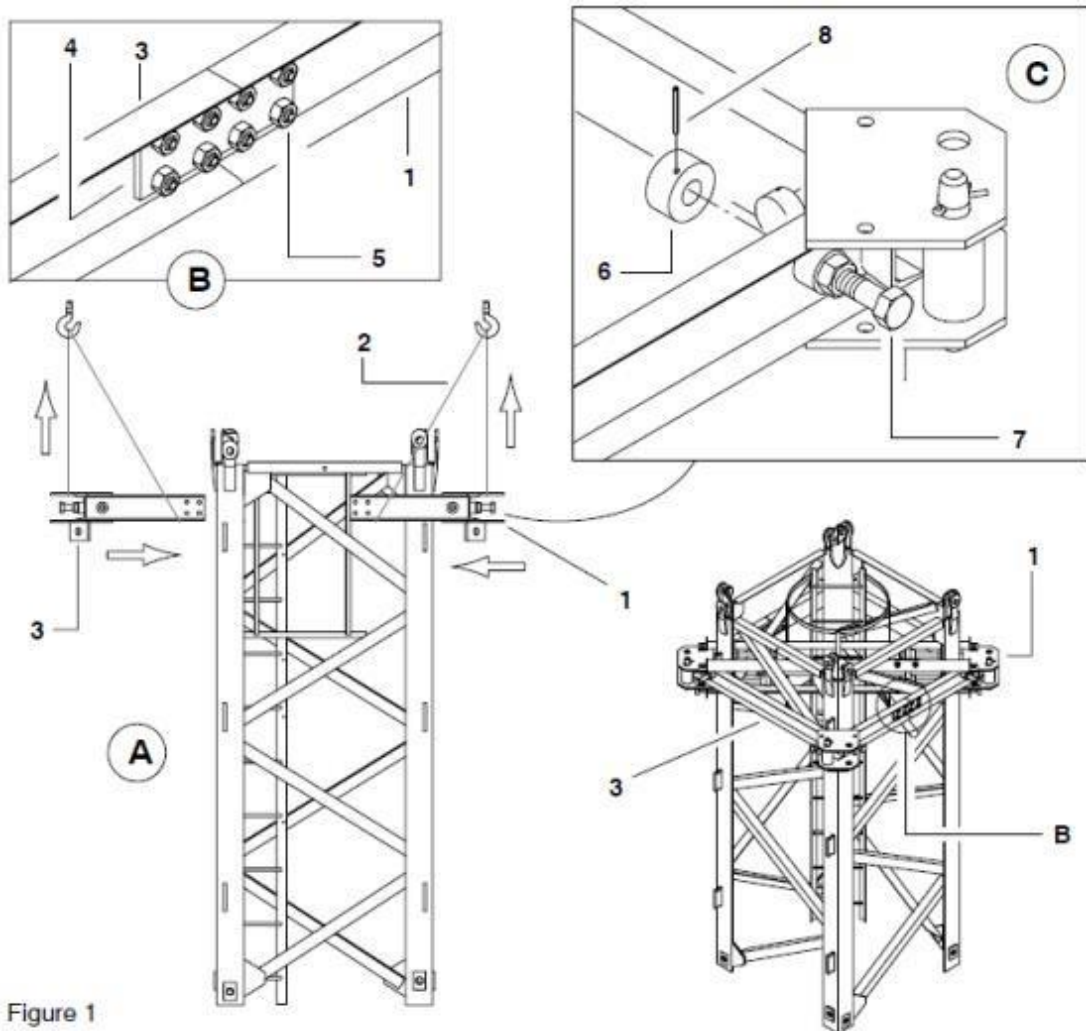
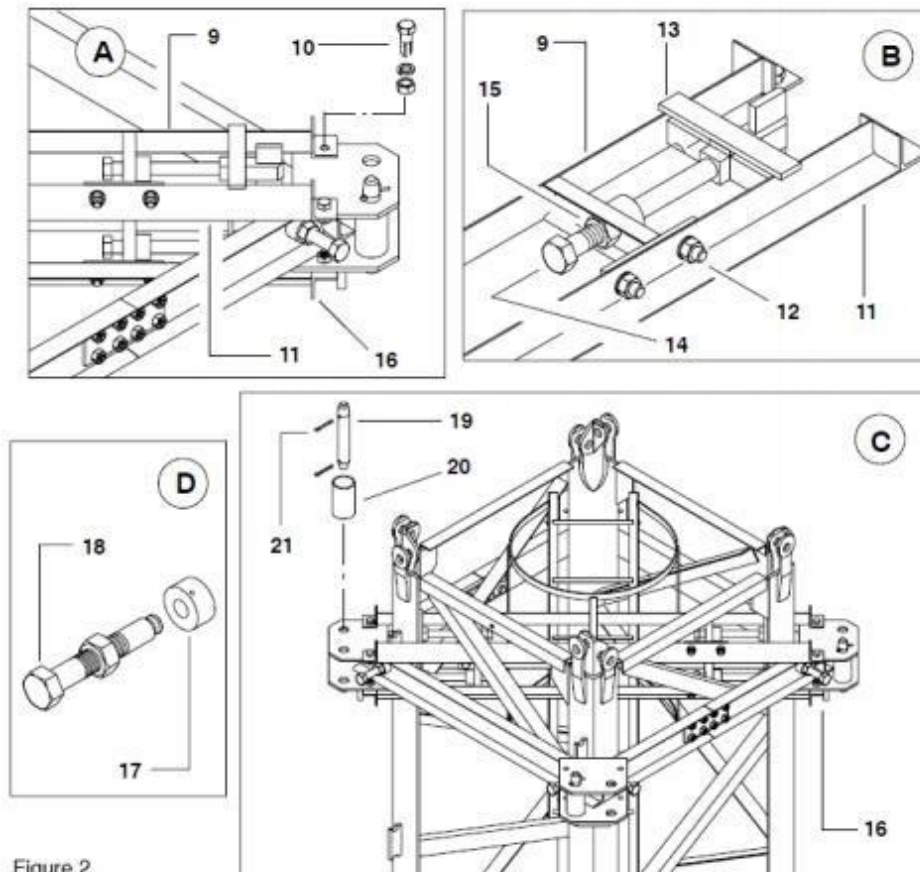

Figure 1

4.5.4.6 Fitting the diagonal bracings

- Introduce the diagonal bracing (9) on the half frames and pin-connect it by means of the 2 fishplate bolts H 20x48 (10) (Detail A - Figure 2).
- Proceed in the same way for the diagonal bracing (11) (Detail A - Figure 2).
- Link the 2 diagonal bracings (9) and (11) together and pin-connect them using 2x2 screw bolts HM20x40 (12) (Detail B - C - Figure 2).
- Fit into the bracings the tightening stops (13) as well as the screws (14) and the nuts (15) (Detail B- Figure 2).
- For fitting the diagonal bracings (16) located under the frame, observe the preceding operations (Detail A - C - Figure 2).
- By operating the screws (14), lock the tightening stops (13) in the mast uprights (Detail B - Figure 2).
- Readjust the locking of the frame onto the mast section; for this, tighten the blocking round bars (17) by operating the screws (18) (Detail A - D - Figure 2).
- Fix the frame to the anchorage device provided by the customer by means of the 4 shafts 40x175L(19), the spacers (20) and the split pins (21) (Detail C - Figure 2).



4.6 Climbing inside the building

4.6.1 General notes

The dimensions and weights given in the tables on the following pages correspond to:

- The first line of each group indicates the dimensions and the weight of the component assembled with the parts as they are shown in the drawing.
- The following lines indicate the dimensions and weights of the main parts according to representation.
- The direction of dimensions L, l and h with respect to the mark concerns the main parts only.

Important: The sum of the weights of the main parts is lower than the weight of the equipped component because the weight of pins, bolts, small accessories, etc. is not taken into account.

4.6.1.1 Tower section S24G

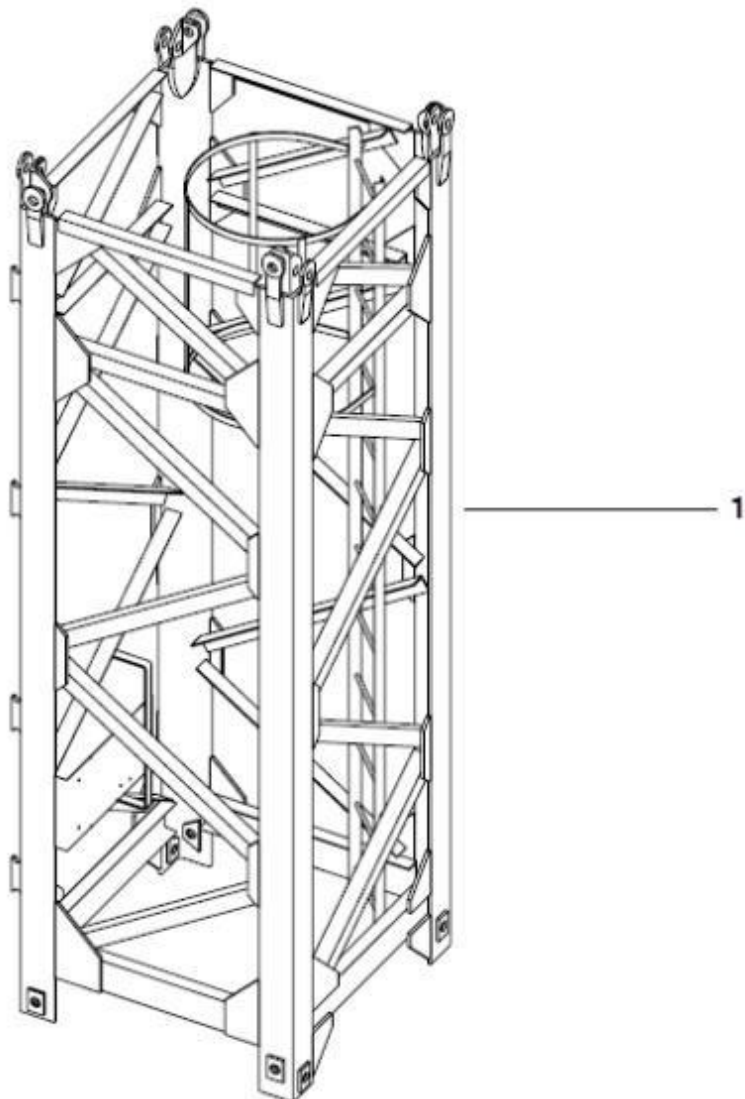
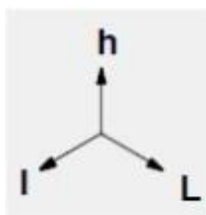

No.	Quantity	Designation	L	i	h	P (Kg)
		Complete tower section S24G	1290	1260	3945	1136
1	1	Unequipped tower section S24G	1290	1260	3945	

4.6.1.2 Tower section S24H

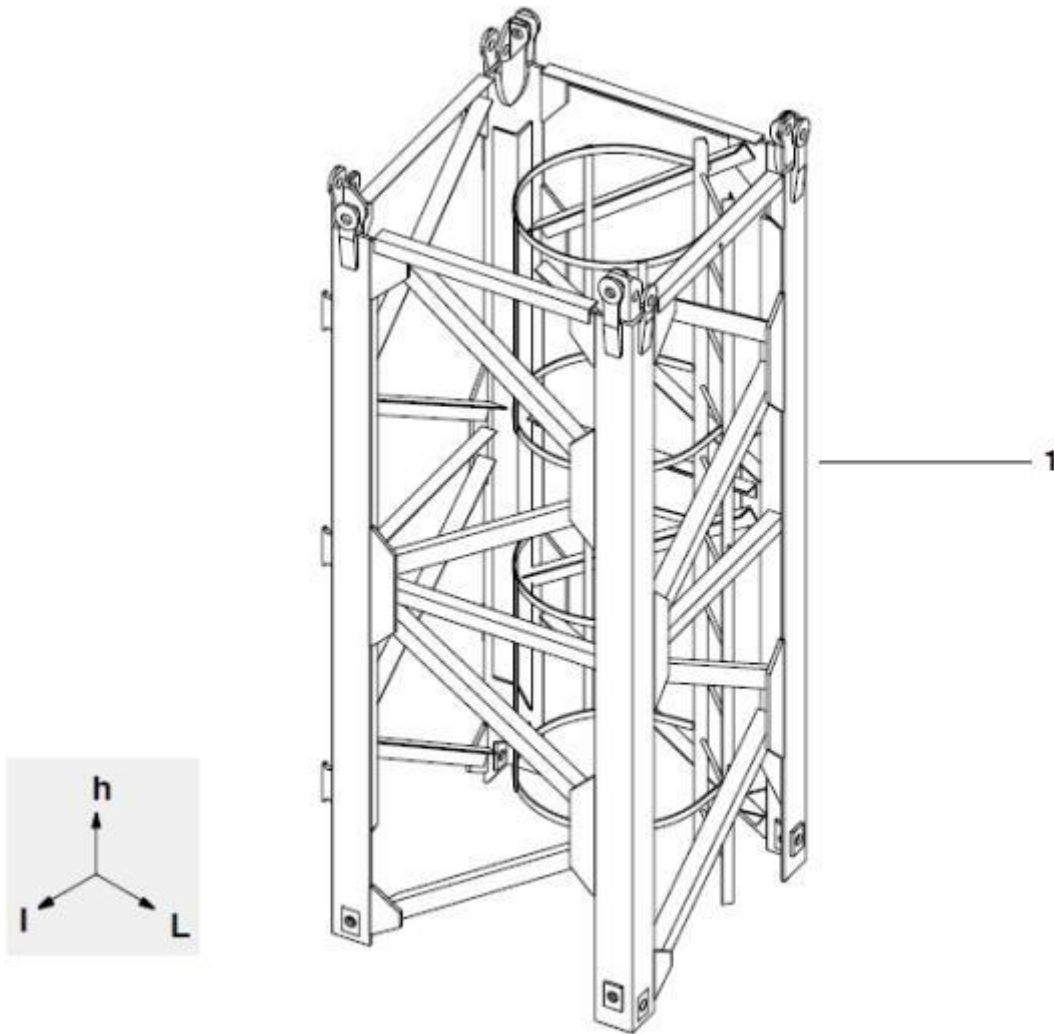

No.	Quantity	Designation	L	i	h	P (Kg)
		Complete tower section S24H	1290	1260	3195	980
1	1	Unequipped tower section S24H	1290	1260	3195	

4.6.1.3 Equipped climbing collar B125A

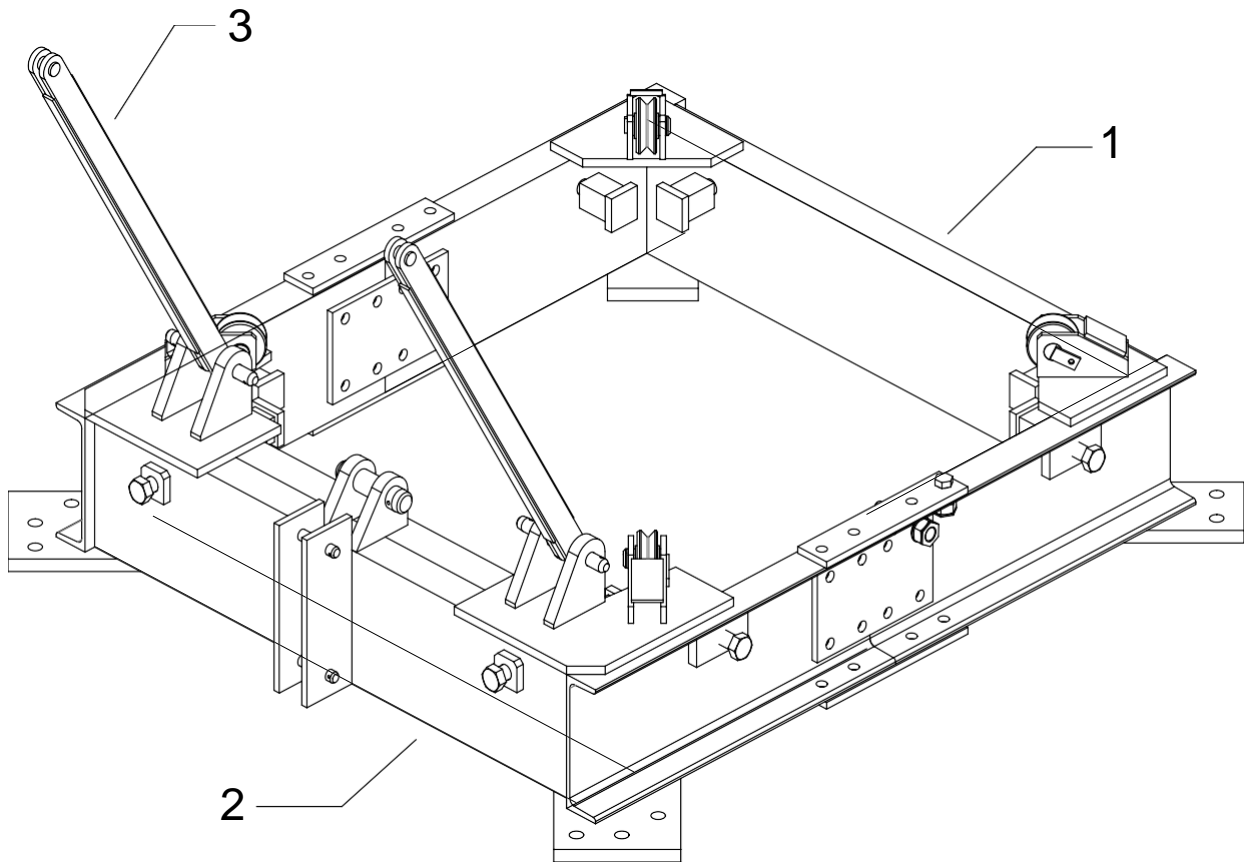

No.	Quantity	Designation	L	i	h	P (Kg)
	1	Equipped climbing collar B125A	2100	2150	510	700
1	1	Front half climbing collar	2100	1075	470	300
2	1	Rear half climbing collar	2100	1075	510	380
3	2	Link	1130	65	72	

4.6.1.4 Climbing equipment

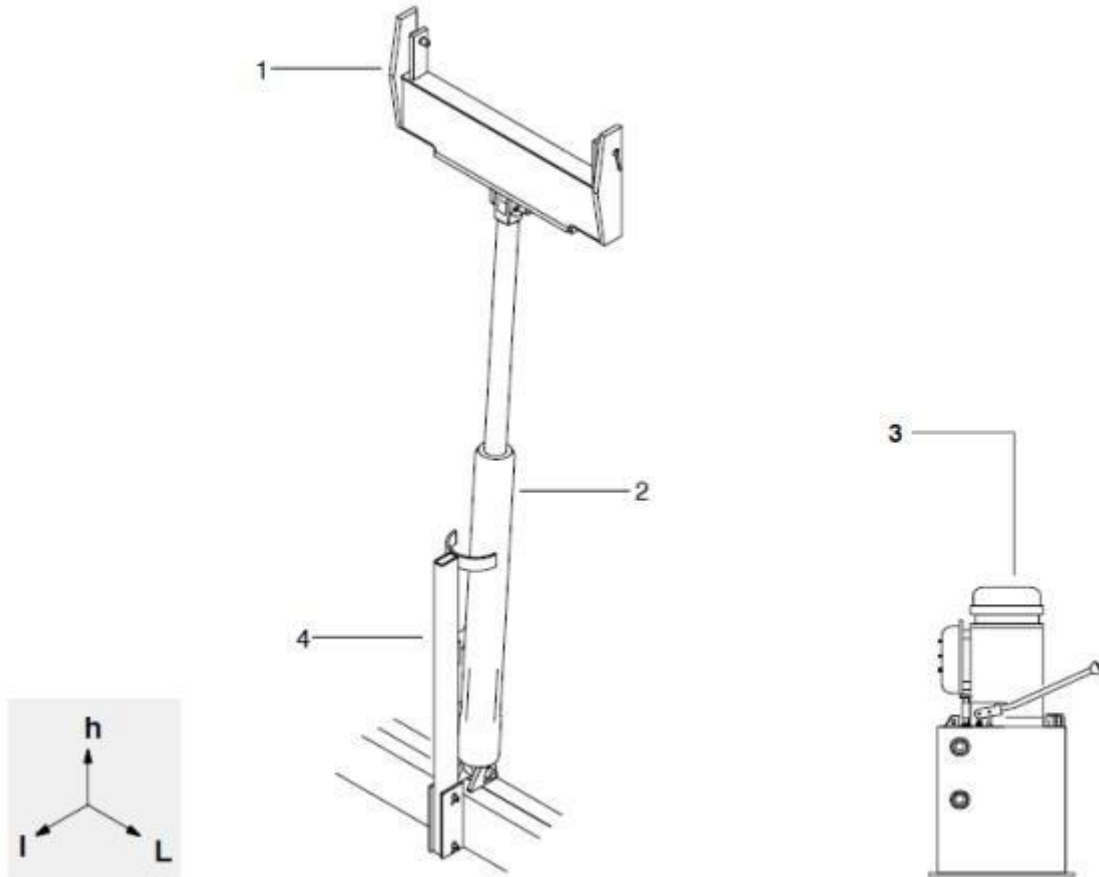

No.	Quantity	Designation	L	i	h	P (Kg)
1	1	Equipped telescoping yoke	1240	140	685	131
2	1	Hydraulic cylinder (without oil)	1740	205	205	202
3	1	Hydraulic unit (without oil)				190
4	1	Cylinder stop	240	220	1140	22

4.6.2 Installation

4.6.2.1 Opening the floors

Provide for a sufficient opening in each floor in order not to hinder the passage of the crane. Therefore, it is essential to observe the dimensions indicated in (Detail A – Figure 1).

- Climbing inside the building can be carried out in two different ways:

- either onto two support beams (1) provided for this purpose and prepared by the customer according to the reactions given in the DATA SHEET (Detail B – Figure 1).

- or directly onto the floor. In this case, these floors must take up the vertical and horizontal reactions given in the DATA SHEET. The climbing collars will be blocked onto the floors by means of threaded rods or equivalent accessories (Detail C – Figure 1).

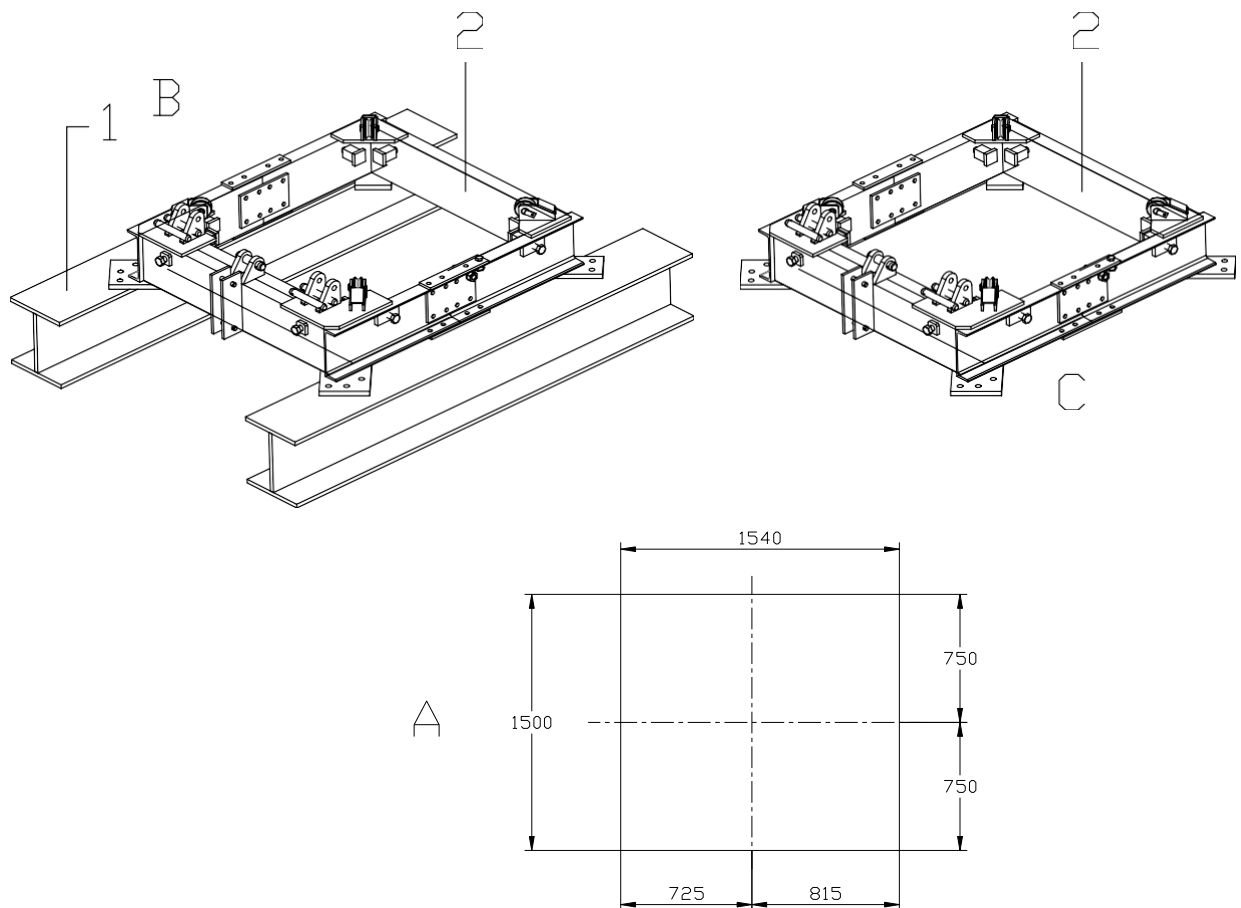

Figure 1

4.6.2.3 Composition of the crane tower

The composition of the crane tower and the minimum distance between the climbing collars are given in the DATA SHEET.

Compulsory:

The reinforced mast section (1) must always be located just opposite to the second climbing collar (2). This must be **COMPULSORILY** taken into account for placing it during the erection of the crane tower (Detail A - Figure 1).

For the actual minimum dimensions, see DATA SHEET.

In order to avoid any incident during telescoping and operating the crane, install a floor (3) onto the lower collar of the basic mast (Detail A - Figure 1).

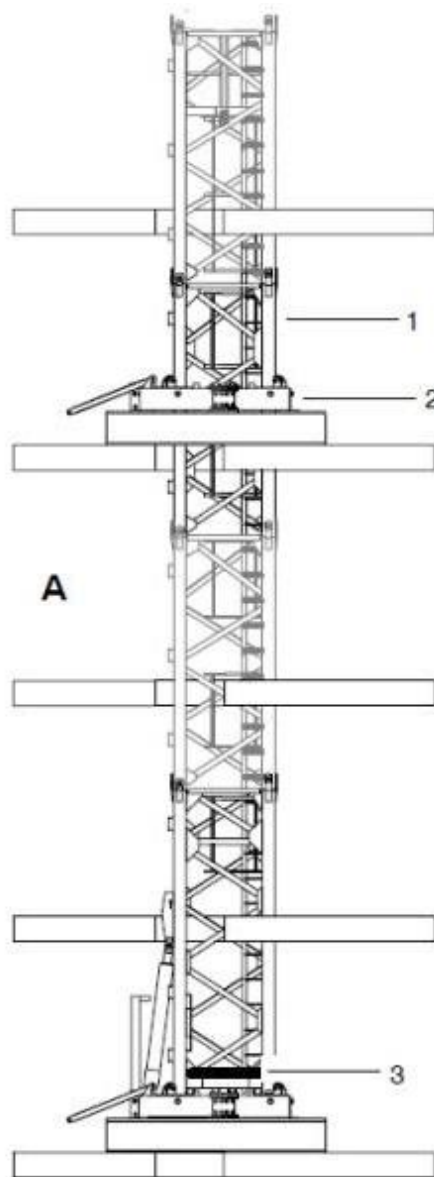

Figure 1

4.6.2.4 Summary of mast sections for crane tower 1.2m

- Mono block basic mast – length 3.75m (S24G)

Basic mast which can be telescoped, with lugs (4 steps) (Detail A – Figure 1).

Lower fish plating Ø 40

Upper fish plating Ø 40

- Reinforced mono block mast section – 3 m length (S24H)

Reinforced mast section which can be telescoped, with lugs (3 steps) (Detail B – Figure 1).

Lower fish plating Ø 40

Upper fish plating Ø 40

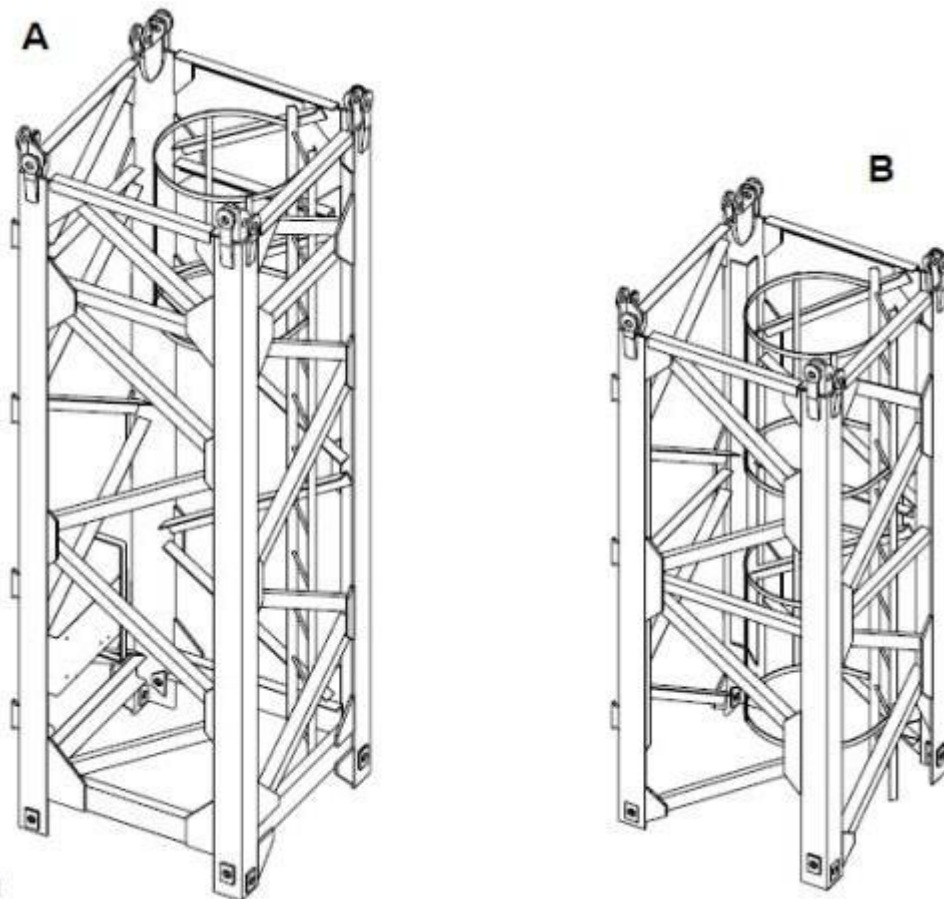

Figure 1

- Mono block standard mast section – 3 m length with normal access

Standard mast section which can be telescoped, with lugs (3 steps) (Detail A – Figure 2) and back loops (1) positioned at the resting platform exit (Detail B – Figure 2).

Lower fish plating Ø 40

Upper fish plating Ø 40

- Mono block standard mast section – 3 m length – with normal access

Standard mast section which can be telescoped, with lugs (3 steps) (Detail C – Figure 2) and back loops(1) positioned on the normal access for mast sections located between a resting platform and an access at the resting platform exit (Detail D – Figure 2).

Lower fish plating Ø 40

Upper fish plating Ø 40

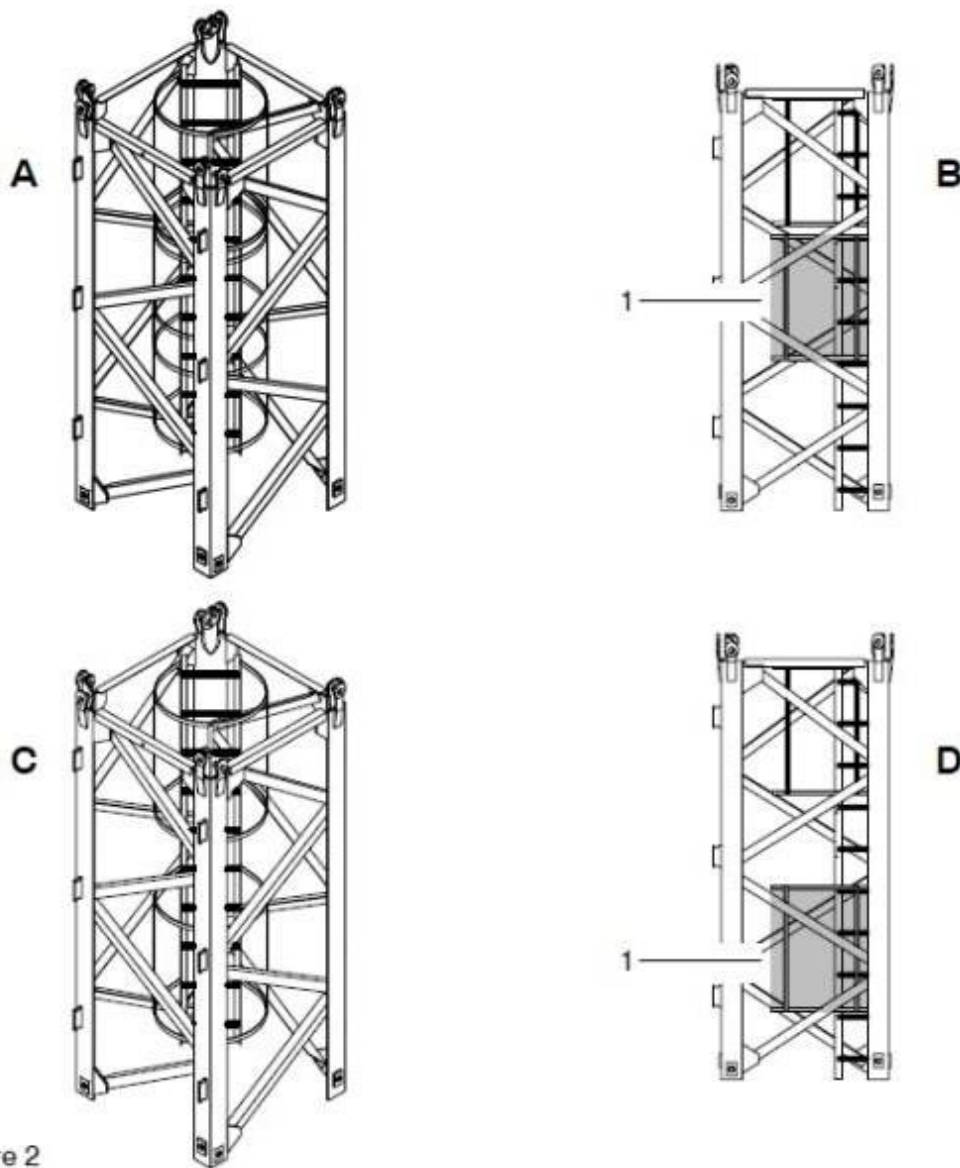

Figure 2

- Mono block standard mast section – 3 m length – with resting platform
- Standard mast section which can be telescoped, with lugs (3 steps) (Detail A – Figure 3).
- Lower fish plating Ø 40
- Upper fish plating Ø 40

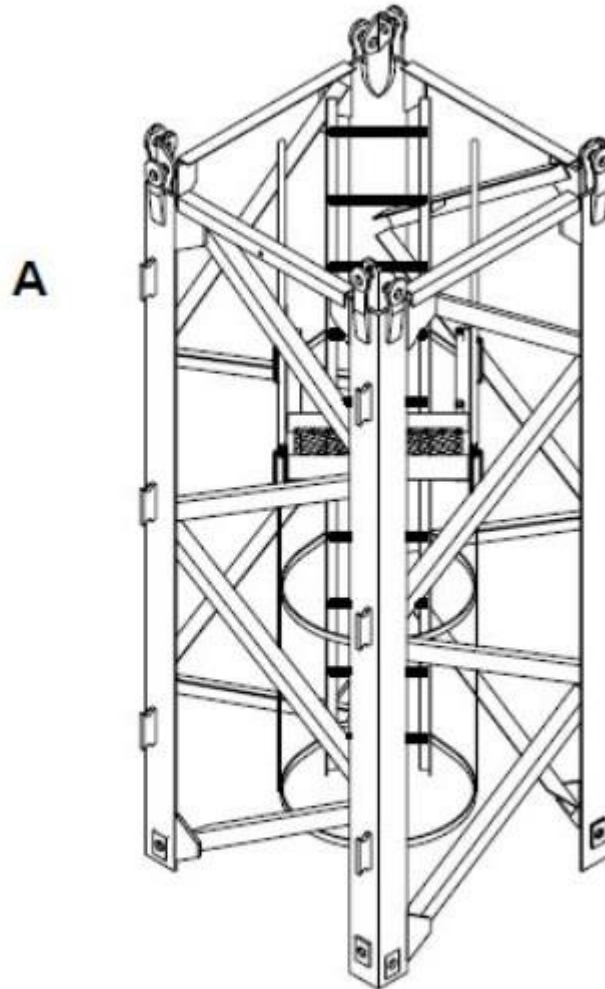

Figure 3

4.6.2.5 Assembling the climbing collars

- Three climbing collars are required, two for working and one in waiting position.
- Each collar is composed of two parts which are fitted around the mast and assembled by fish plating (Detail A – Figure 1):
 - a front half collar (1) (Detail B – Figure 1)
 - a rear half collar (2) (Detail B – Figure 1).

- The internal dimensions of the collars correspond to the minimum opening to be carried out in each floor. Therefore, observe the dimensions given in chapter 2 and the positions with respect to the crane axis.

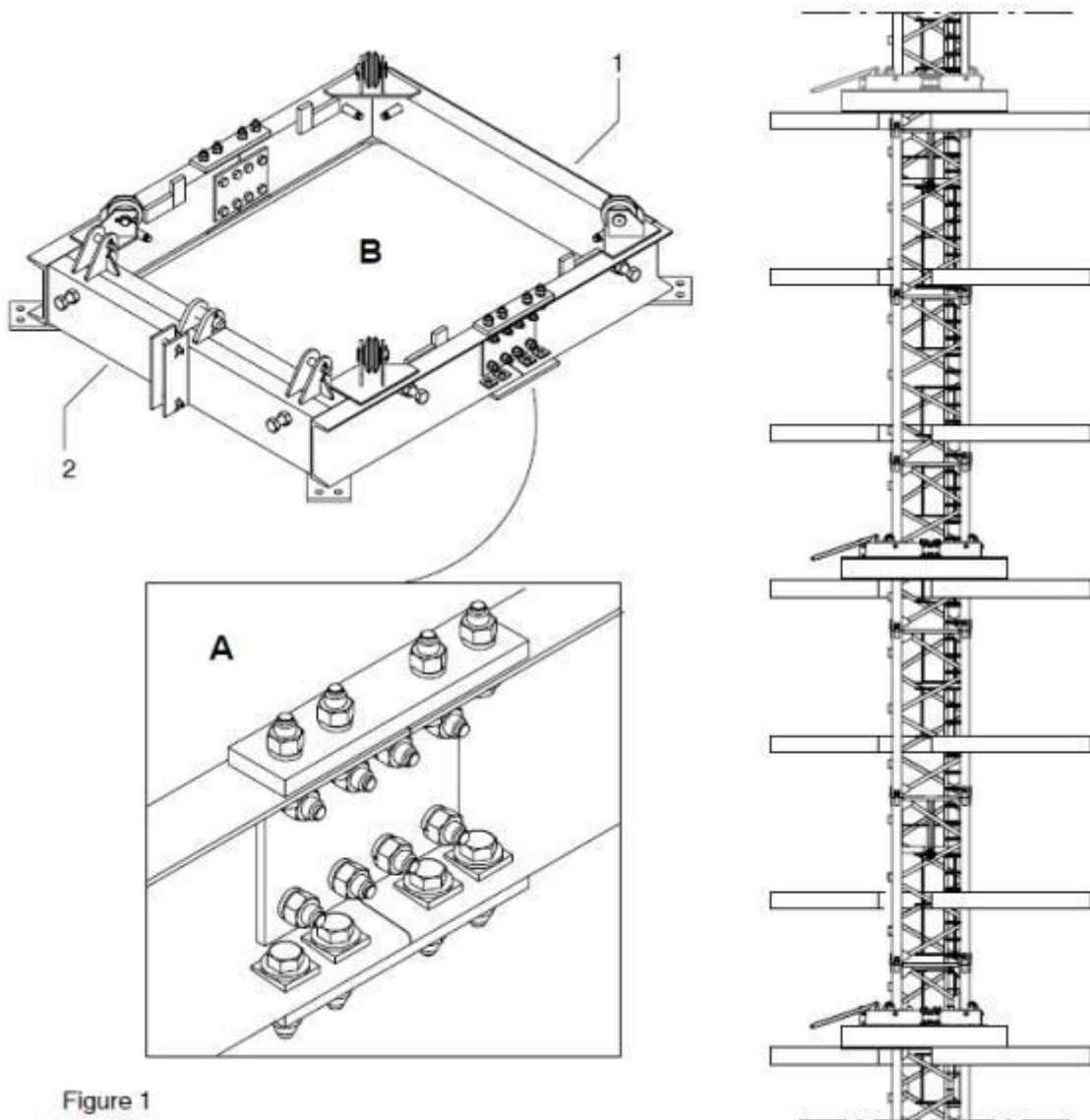

Figure 1

4.6.2.6 Fitting the climbing collars

There are two assembling possibilities:

- Assembling recommended:

The beams (1) are placed under the fish plating (2) (Detail A – Figure 2). The lower fishplates (3) are suppressed (Detail B – Figure 2), a wedging (4) under the fish plating compensates the thickness of the collar gussets (Detail C – Figure 2).

- Possible assembling:

The beams (1) are placed in the opposite direction to the fish plating (2) (Detail D – Figure 2). The fish plating are complete with the lower fishplates (3) (Detail B – Figure 2).

- In no circumstances the beams (1) and the wedges (4) must exceed inside the collars.
- Provide the drilling of the beams for fixing the collars.

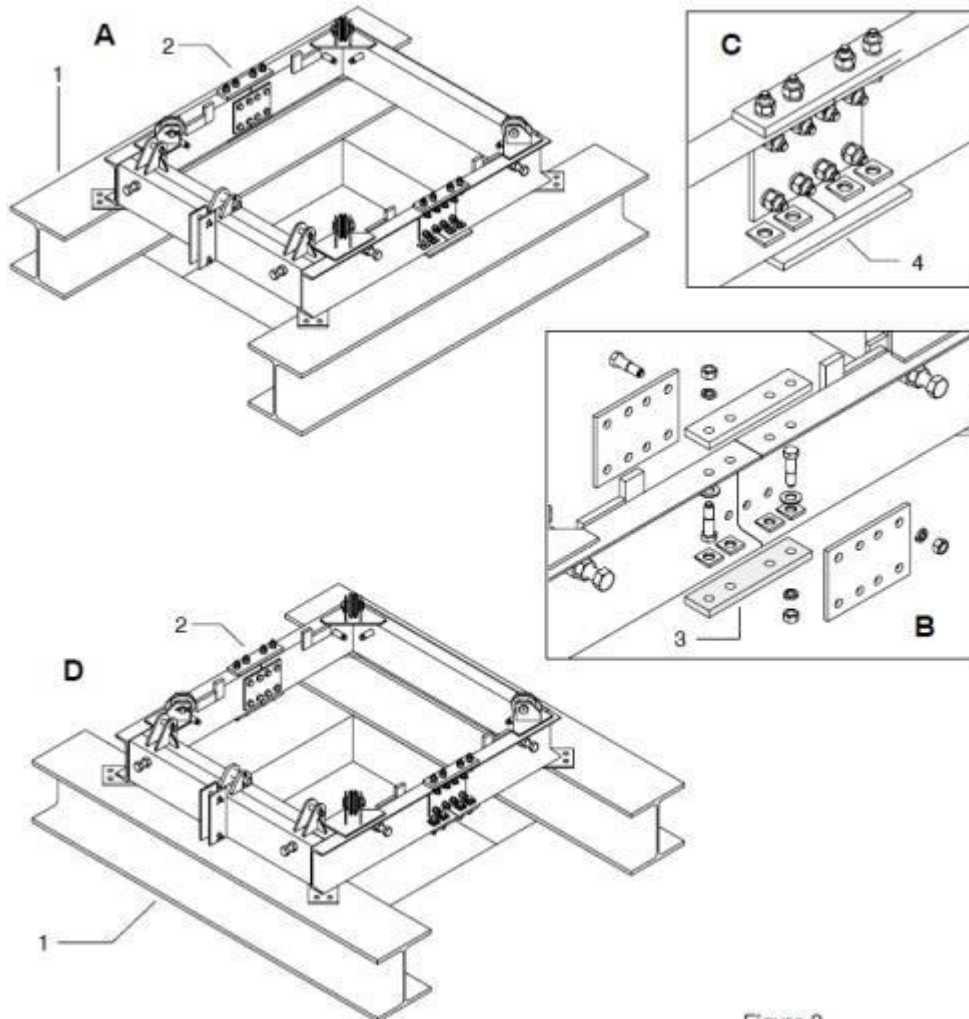

Figure 2

4.6.2.7 Mounting the climbing collars

- The position of the climbing collars is determined depending on the chosen intermediate slab (during working, the second collar must be compulsorily at right angle of the reinforced mast section).
- Two climbing collars are necessary for the first telescoping sequence, the third will be kept in waiting position.
- Check before fitting the collars, that the slabs are dry enough.

- Fitting consists in positioning the half collars around the crane tower and fish plating them together (according to the fitting paragraph 2.6).
- The half collar equipped with the cylinder fixing gussets must be compulsorily placed on the telescoping lug side.
- Fit rigidly the collars to the building, either by bolting directly to the slab or by means of the support beams.

Fit onto each collar the links (1) by means of the shafts (2) and fix with split pins (Detail A – Figure3)

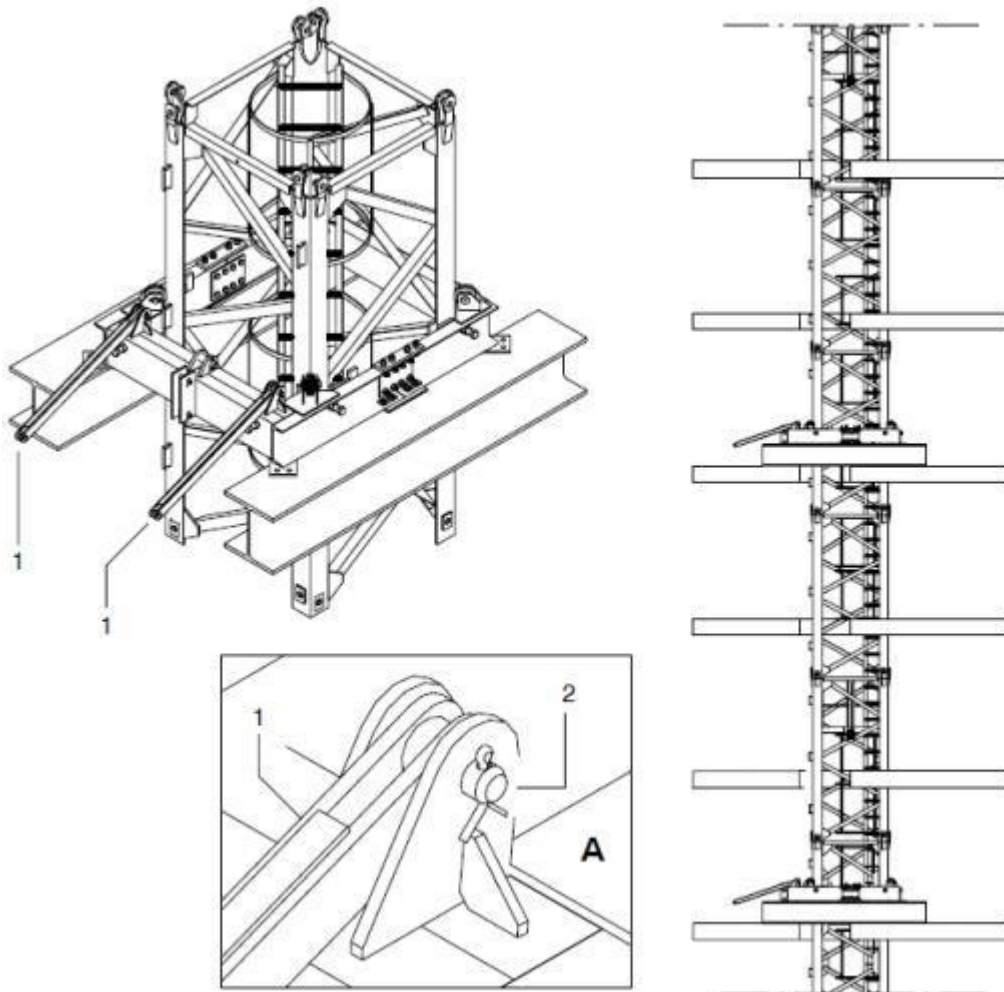

Figure 3

4.6.2.8 Collar equipment for climbing

- Fit the cylinder stop (1) onto the collar by means of the shafts (2); fix with split pins (Detail A – Figure4).
- Fit the telescoping cylinder (3) by means of the shaft (4), fix with split pin (Detail B – Figure 4).

- Fit the telescoping yoke (5) onto the cylinder by means of the shaft (6); fix with split pin (Detail B –Figure 4).
- At each fitting of the hydraulic unit, cylinder and telescoping yoke onto the upper collar, do not forget to dismantle and to refit the cylinder stop.
- Carryout the connection between the cylinder and the hydraulic unit.

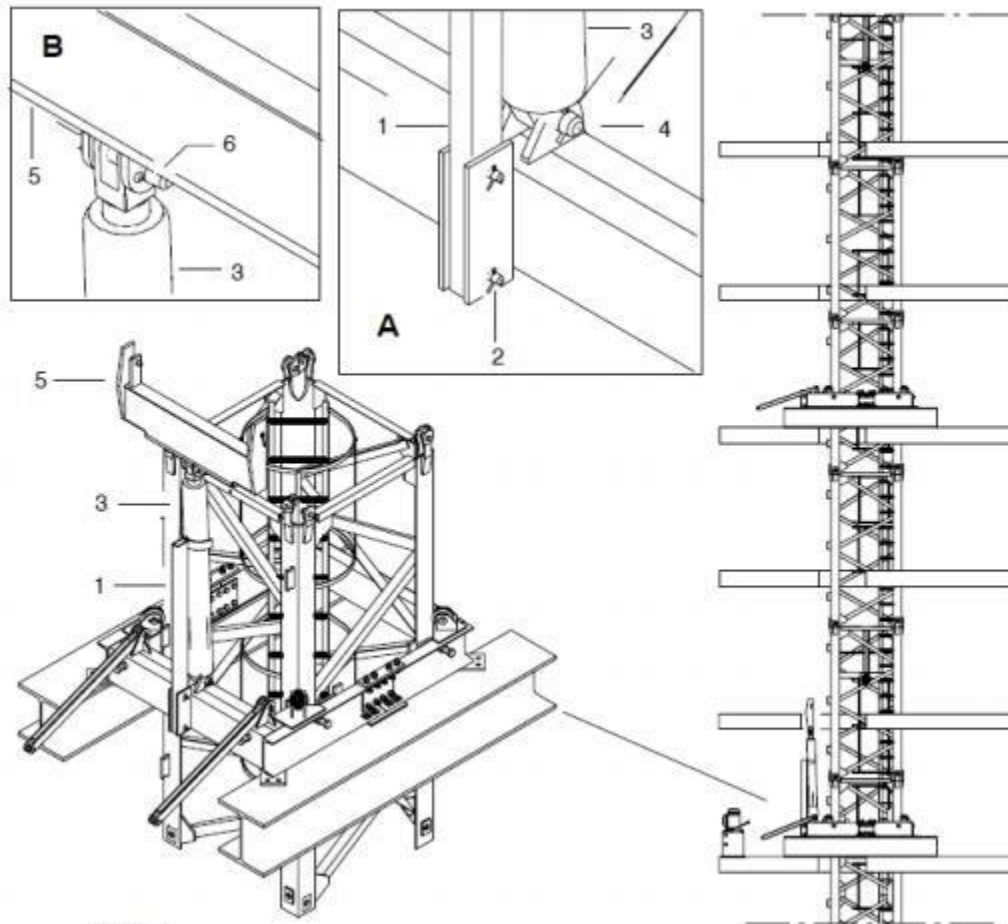

Figure 4

4.6.3 Balancing the crane for telescoping

Special instructions

- For a correct operation of the climbing equipment, it is essential that the center of gravity of the lifted crane part is in the axis of the cylinder.
- This condition is fulfilled by moving the jib trolley (with appropriate load, if required) to the balancing position.

- The given distances are theoretical; they depend in particular on the actual weight of the counter jib ballast.
- Make sure that this weight corresponds to the jib and counter-jib lengths used.
- The balancing position is obtained by checking the play of the guiding rollers of the upper climbing collar and by reading the minimum pressure required for telescoping on the pressure gauge of the hydraulic unit.

During the balancing operations, it is forbidden:

to SLEW the jib

to MOVE the jib

to OPERATE the hoist winch (hoisting or lowering)

4.6.4 Telescoping

General instructions

- In order to avoid any risk of accident, the telescoping operations must be carried out according to the instructions given in paragraph 2 and by observing the following orders:

It is forbidden:

to SLEW the jib

to MOVE the jib

to OPERATE the hoist winch (hoisting or lowering)

Beside the telescoping operations:

- Never let the telescoping assembly rested on the cylinder.
- Telescoping can only be carried out with a wind not exceeding 60 km/h.

After each climbing operation, check the perpendicularity of the crane.

4.6.4.1 First telescoping sequence

- Rest the yoke (1) under a set of telescoping lugs (2) welded on the mast section (Detail A – Figure 1). Lock the yoke (1) by means of the shafts (3), split pins (4), fixing flanges (5) and screws (6) (Detail B and C – Figure 1).
- Slew the crane jib in opposite direction to the telescoping cylinder and move the jib to the balancing position (see paragraph 2).
- Withdraw the shafts (7) connecting the part to be telescoped to the crane part remaining on the ground (mast section or fixing angles). Extend the cylinder (8) in order to disengage the base of the crane part to be telescoped (Detail D – Figure 1) (These operations are to be carried out only during the first telescoping sequence).

- Verify the balancing position of the crane; for this, it is necessary to check the play of the rollers of the upper climbing collar. If necessary, readjust this balancing position by moving the jib forward or backward.
- If the play is on the jib side, the jib must be moved backward ← (direction of jib foot).
- If the play is opposite to the jib, the jib must be moved forward → (direction of jib nose).

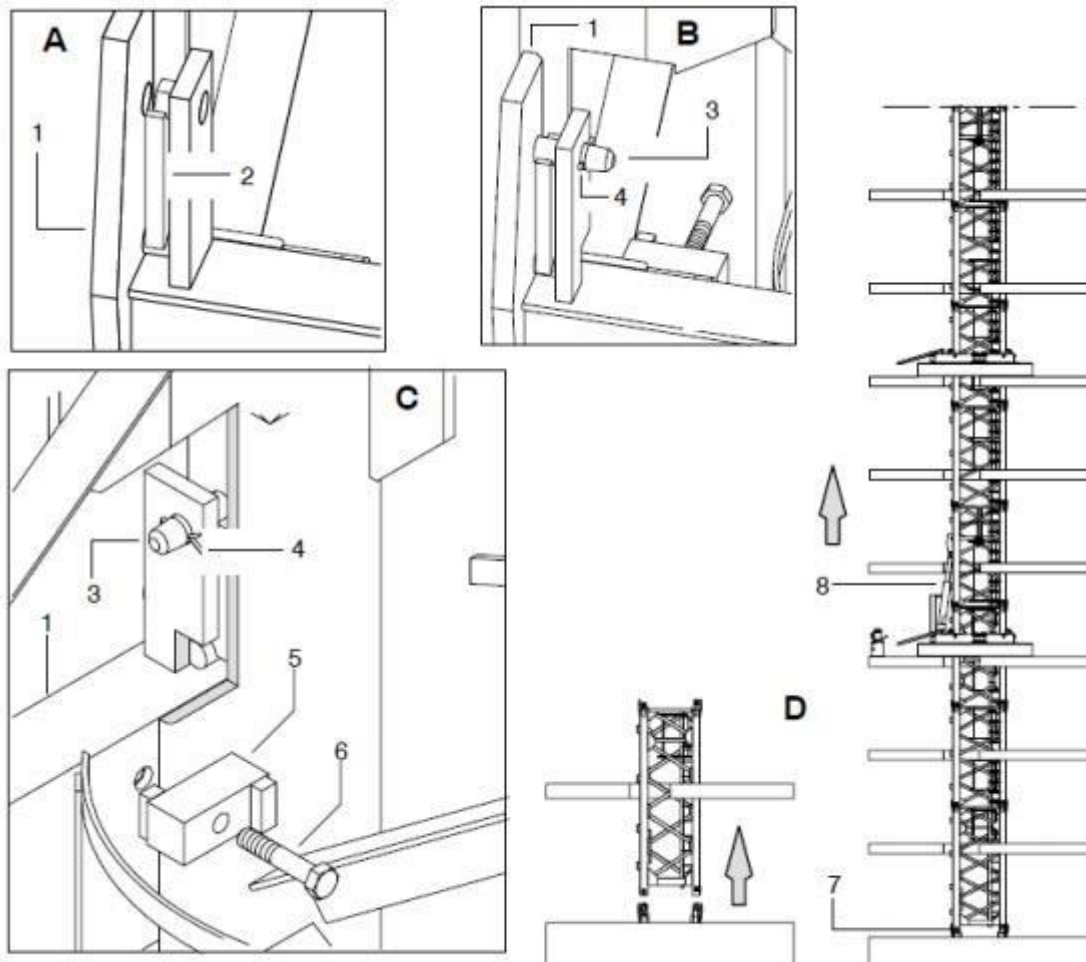

Figure 1

- Having finished balancing, continue extending the cylinder (1) in order to allow folding down the connecting links (2) under the lugs (3) (Detail A – Figure 2).
- Lower again in order to rest the lugs (3) onto the links (2) (Detail B – Figure 2).
- Unlock the telescoping yoke (4) by withdrawing the shafts (5) and the fixing flanges (6) (Detail C – Figure 2). Retract the cylinder (1) and lock again the telescoping yoke (4) onto the set of lugs below.
- Extend the cylinder (1) for a new stroke. Repeat these operations as often as necessary in order to bring the crane tower base on the level of the first telescoping collar.

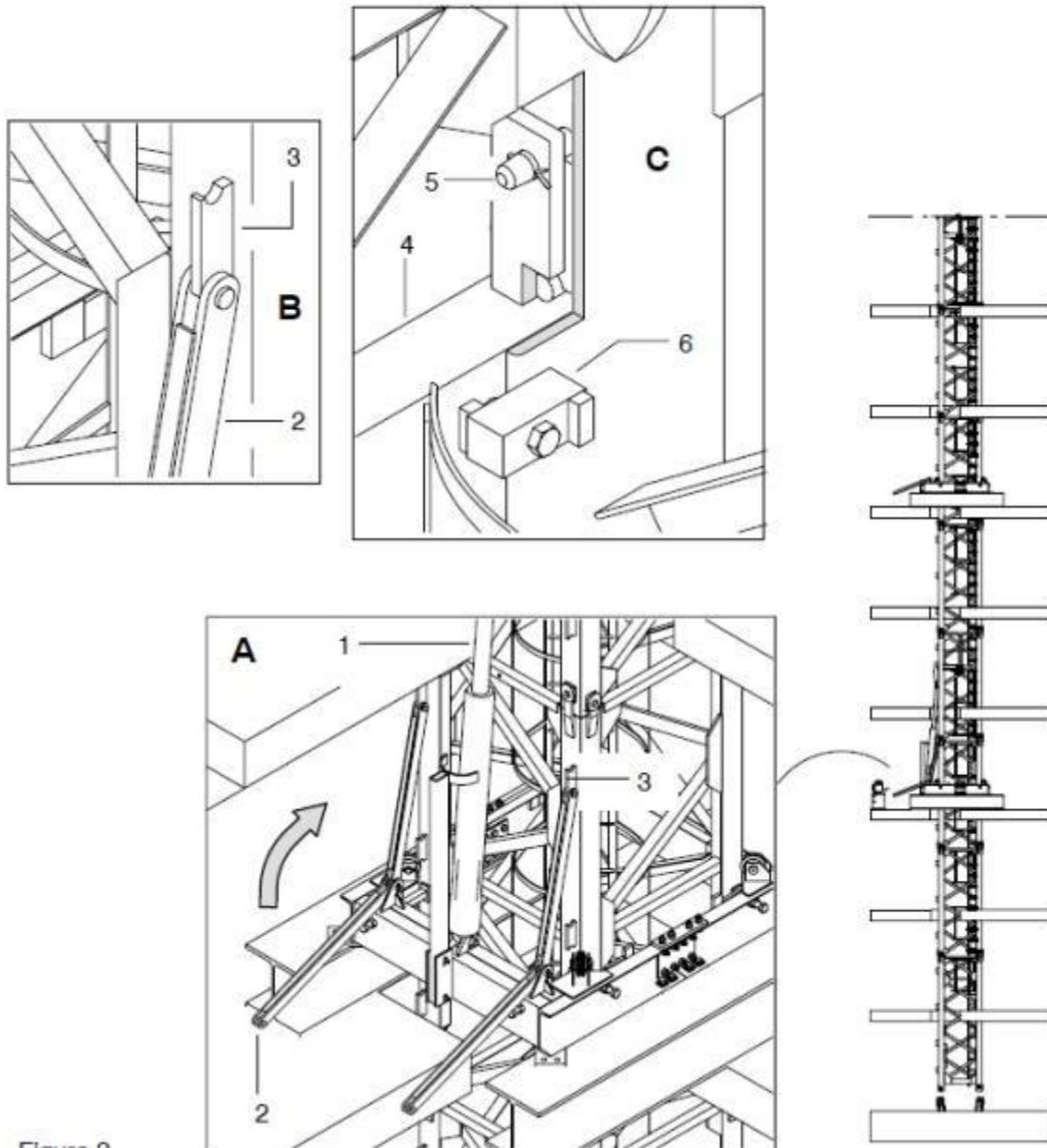

Figure 2

- When the telescoping sequence is finished, telescope slowly and take care that the resting shafts (3) can be inserted between the collar (4) and the base collar of the basic mast (1) of the crane; fix with split pins (Detail A – Figure 3).
- Lower again until the crane comes to rest onto the resting shafts (3) (Detail A – Figure 3).
- Lock compulsorily the screws (6) and (7) onto the collars (4) and (5) by inserting the wedges (8) and (9) between the screws and the mast section. Per collar, there are 2 long wedges (8) fitted on the cylinder side with the screws (6), and 6 short wedges (9) fitted with the screws (7) on the three other sides. Then lock the counter nuts (10) of the screws (6) and (7) (Detail A and B – Figure 3).

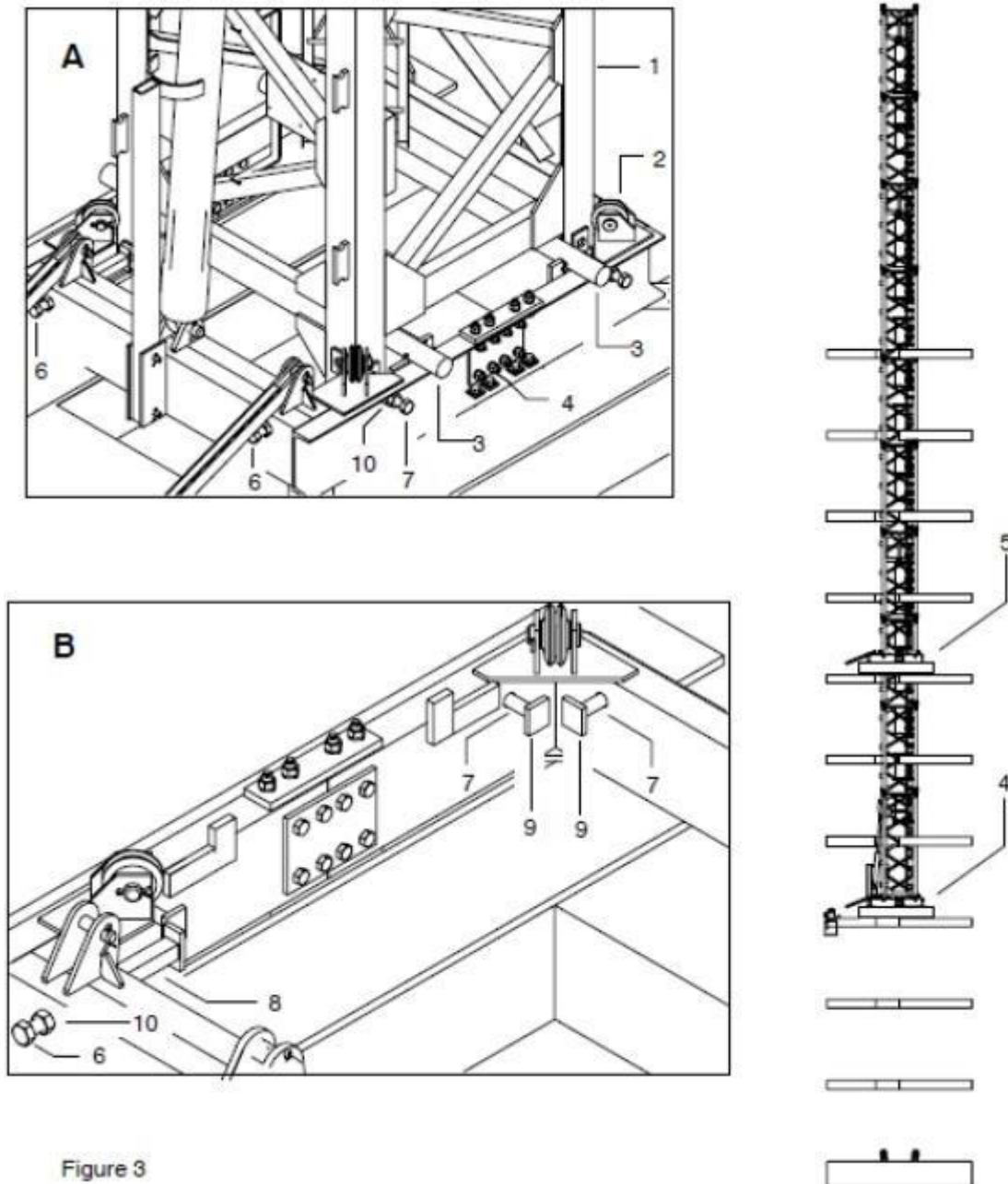

Figure 3

4.6.4.2 The following telescoping sequence

- Having checked that the slab is dry enough, fit the third collar (1) depending on the chosen intermediates lab.
- Refit the hydraulic unit, the hydraulic cylinder, the telescoping yoke as well as the cylinder stop onto the next collar above (2) (Detail A – Figure 4).
- Loosen the screws (4) and (5) on the collars (2) and (3) and remove the wedges (6) and (7) (Detail B –Figure 4).
- Rest the yoke (8) under a set of lugs and lock it by means of the shafts (9), their split pins and the fixing flanges (10) (Detail C – Figure 4).
- Put the cylinder under pressure and balance it. Repeat the preceding operations until the telescoping phase is finished.

- As soon as the crane has left the lower collar (3), dismantle the latter and put it in waiting position until the next telescoping sequence where it will be fitted on a slab above the second collar by observing the chosen intermediate slab.

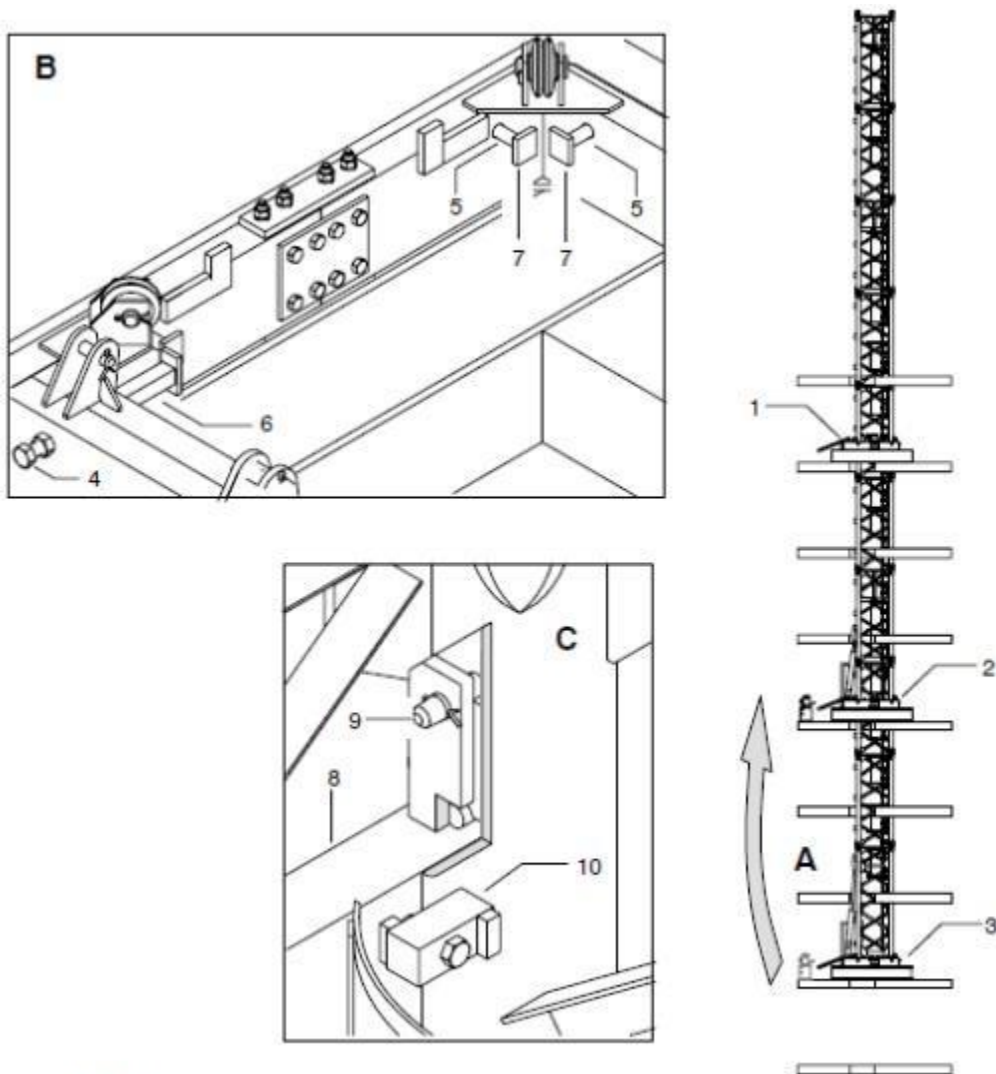

Figure 4

4.6.5 Dismantling

- In general, the crane cannot be lowered inside the building, and it is necessary to dismantle it into smaller parts of reduced dimensions and weights.
- Special dismantling accessories are used for these operations. However, the conditions of each site require particular solutions. For this, it is recommended to consult our AFTER SALES SERVICE.



Safety device

Chapter 5

5.1	General	130
5.2	Position of safety devices	130
5.3	Automatically zero positioning.....	131
5.4	Dead-man switch	131
5.5	Hoist limit switch	131
5.6	Luffing limit switch.....	132
5.7	Load moment limiter.....	132
5.8	Rope retaining brackets	133
5.9	Load hook	133
5.10	Slewing unit – counterweight protection.....	133
5.11	Load pin	133

5.1 General

The GHD4015-6 is equipped with all safety devices prescribed on the delivery day. The purpose of the safety devices is to prevent damage to the crane, caused by operation faults, which endanger the life of all personell on the building site.

During crane operation individual limit switches must not be contacted.

The response of the safety device is always an emergency stop. Only at the beginning of the crane operation should the correct functioning of the limit switches be checked.

5.2 Position of safety devices

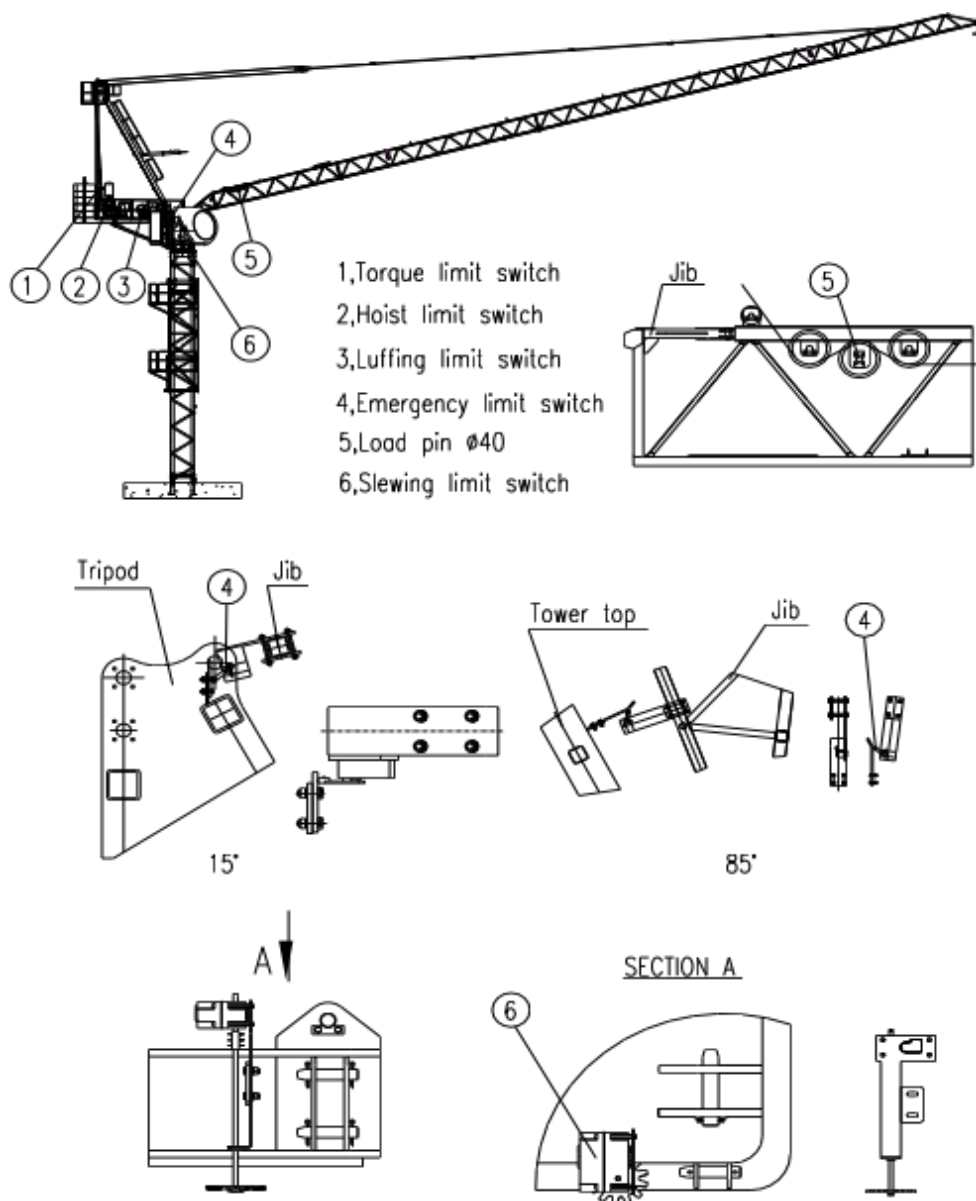

5.3 Automatically zero positioning

The push button “Crane on” is locked via the zero contacts of the control lever. The main contactor can only be switched on when all control levers are in zero position. This ensures that no drive unit can be switched on unintentionally.

5.4 Dead-man switch

Both control levers in operator cabin are spring-loaded and will return to zero position automatically. The right hand side control level is equipped with dead-man switch. Operator has to push down the control lever to operate the crane. When releasing the dead-man switch, all crane functions will stop.

Dead-man switch can be by-passed on fixed operators control stands when levers are spring loaded to return automatically to zero.

5.4.1 Audible warning signals

From control stand in operators cabin a warning horn can be activated via push button.

For cranes on travelling bases a warning horn is activated when crane is in motion.

A Control lever for travel unit and hoist unit.

12 Push button horn.

5.5 Hoist limit switch

The top and bottom end position of the hook block are limited by way of a limit switch. This limit switch is activated from the hoist gear.

- When adjusting the cam disks, please do not forget to include the deceleration distance.
- The limit switches must be set in such away that they switch off in the bottom hook position; min. 2 rope windings (safety windings) must remain on the hoist drum.
- For the movement in up direction, a prelimit switch exists. The adjustment must be done, so that the hook slows down to step 1, three meters before the maximum hook height is reached.
- The top end position of the hook block must be set in such away that with an empty hook and traveling at full speed, the traveling block comes to standstill 1.5 m bellow the swing arm.

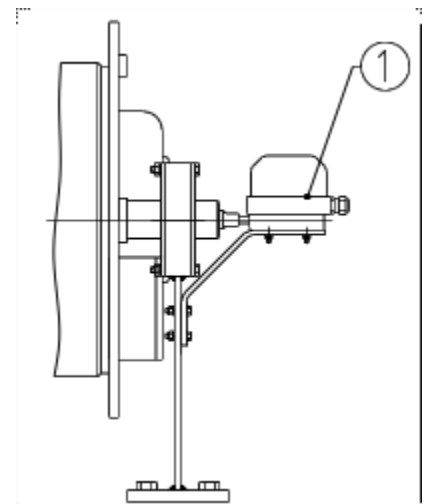

5.6 Luffing limit switch

Luffing travel is limited in the outer and inner position by a gear cam limit switch. The switch is actuated by a sprocket gear from the luffing drum.

- Adjust the luffing travel limit switch by turning the trip cam.

The luffing travel limit switch must be so adjusted that the jib travelling at full speed comes to a standstill before reaching the buffers.

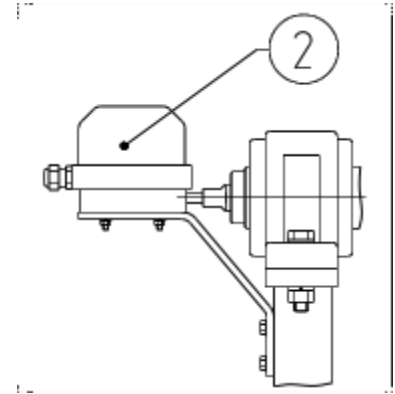

5.7 Load moment limiter

The load moment limiter is located on the A frame of first jib section. Through the load working on the jib end and the resulting stress upon the A-frame-corner support, switch contacts are activated and will switch the hoist unit off in lifting direction and the trolley travel unit in outward direction (towards jib top) as soon as max. permissible load moment is reached. The adjusting of the load moment limiter is accomplished by way of a test load.

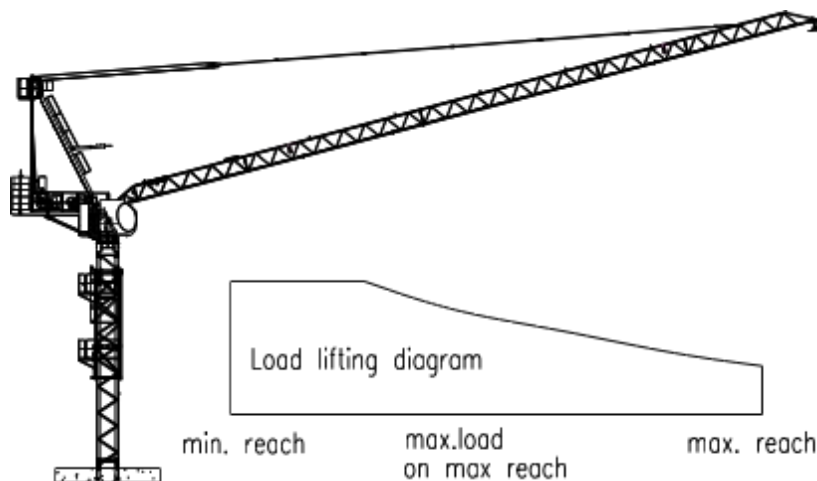

Test loading

The load moment limiter must - apart from the annual Check-ups as prescribed in the regulation for prevention of accidents and after any modification of the crane - also to be checked whenever necessary, e.g.:

- after frequent activation of the load moment limiter
- after times of standstill
- after extreme changes of weather and/or temperatures.

Jib extensions are to be understood as crane modifications.

5.8 Rope retaining brackets

All rope pulleys have rope retaining brackets, which prevent the rope from jumping out of the rope pulley. The crane must not be operated without rope retaining brackets.

5.9 Load hook

In accordance with the Accident Prevention Rules, load hooks are permitted on building sites only when they have been furnished with a hook safety device. Therefore the load hooks have a special safety flap, which must never be removed. See also DIN 15405 (sheet 1) standards: Load hook for hoisting equipment – Supervision when using forged load hooks.

5.10 Slewing unit – countering protection

- Countering of slewing direction is automatically controlled by incremental contact, which is installed in slewing motor.
- The countering is done via breaking steps of the eddy current break.

5.11 Load pin

Adjusting of load pin:

- Lift the empty hook to top position (close to swing arm) and set the touch panel in the cabin in 0 – zero position.
- Lower the hook, hang max. load of 2.5 t on and adjust this value on “touch panel”. The display must show 2.5 t.



Crane operation

Chapter 6

Taking the crane into operation.....	135
6.1 Prior to initial crane operation	135
6.2 Taking the crane into operation	135
6.3 Crane control desk 15kW hoist, 15 kW luffing.....	136
6.4 Control of hoist unit.....	137
6.5 Control of luffing unit.....	138
6.6 Control of slewing unit.....	139
6.7 Instructions for crane operation	139
6.8 Taking the crane out of operation	140
6.9 Taking the crane out of operation when a gale is approaching	141
6.10 Changing of the hoist rope reeving from 4-fall rope to 2-fall operation.....	143
6.11 Changing of the hoist rope reeving from 2-fall to 4-fall rope operation.....	144

Taking the crane into operation

6.1 Prior to initial crane operation

- Check the crane track plant, track end buffers, crane travel safety limit switching and the carting.
- Check that the crane can move and slew absolutely unhindered over the complete height of the building and along the complete crane track. The power feeder cable must unwind from the drum without any problems.
- Check the ballast.
- Check the oil level in the gears and make sure the crane is well lubricated.
- Observe the maintenance intervals as stated in paragraph "Crane Maintenance".
- Check that the ropes are lying correctly inside the pulleys and make sure they are undamaged. The rope running grooves inside the pulleys must be free of any hardened grease, since in that case the rope would elevate and rub against the rope holding bracket.
- Check all pin and bolt connections.
- Open the rail pinch bars.
- Activate the slewing brake.

6.2 Taking the crane into operation

- The crane main switch and the control levers on the control desk must all be in 0 position.
- Establish power connection.
- Turn on the main switch on the crane.
- Check all limit switches and overload safety devices.
- Make sure all brakes of the drives are in perfect working order.

Crane operation

6.3 Crane control desk 15 kW hoist, 15 kW luffing

Crane operation takes place from the control desk inside the operator's cabin. Before the operation is started, the main switch, which is installed in the door to feeder-switch cabinet, must be switched ON and the slewing unit motors must be put back to operating position (neutralize wind free position).

The crane switch (main contactor) is switched ON by pressing push-button CRANE ON (11); this is indicated by way of the indicator light CRANE ON (11). It is only possible to switch on as long as the two control levers are in zero position. These control levers are equipped with automatic 0-seatback.

The crane is switched OFF by pressing the "mushroom" type strike button EMERGENCY - OFF (10) and must only be activated when the crane is at standstill or in a case of emergency in event that a drive does not come to a standstill although it was switched to zero.

The dead-man's button is installed in the control lever on the right side (A). This must be pressed when any of the drives is run, otherwise the crane switch will switch off. With permanently installed control desks this dead-man's button may be bridged as long as the mechanical, automatic 0-seatback is active.

The signal horn can be worked from the push-button (12) HORN with indicator lamp brake lining hoist warn in the right part of the control lever.

The windscreen wiper is switched on by own switch.

The switchboard, which is located in the operators cabin, contains a connection for a socket 220V AC which is supplied by means of a special transformer. Further is this switchboard provided with terminals to connect air conditioner 110V AC and max. power consumption of 1kVA or respectively 1kW with the transformer mentioned above.

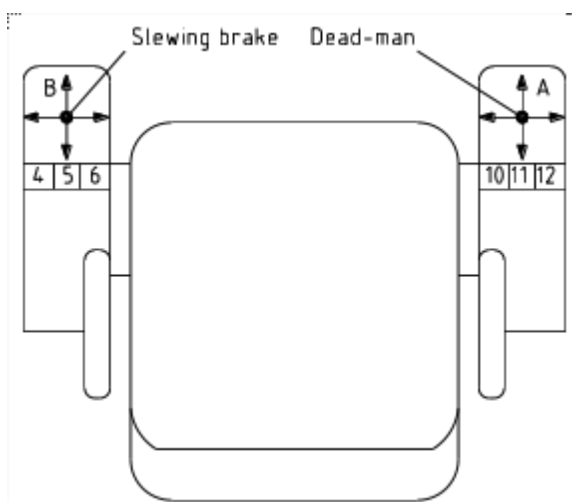

A - control lever for hoist unit and crane travel unit with bridged dead-man's button

B - control lever for luffing unit and slewing unit with push-button for slewing retaining brake

4 – Light for 95% load moment

5 – Light for 100% load moment

6 – Light for 105% load moment

10 – mushroom type strike button EMERGENCY-OFF

11 – illuminated push button CRANE-ON

12 – push button horn with lamp for brake lining hoist

6.4 Control of hoist unit

The hoist unit is driven by a 15 kW slip ring motor and is equipped with a retainer brake and an eddy-current brake.

If the brake lining of the retainer brake has become worn, the indicator lamp will light up. If the brake lining is not changed, the succeeding contact will switch off the steps 3-4-5 and it is then only possible to drive in the steps 1 and 2.

The control is accomplished over 4 switching steps in the lowering direction and 5 switching steps in hoisting direction. In the first two steps of each direction the eddy-current brake is switched on. These steps are only meant for lifting off and setting down the load and should only be used for a short time. They are not regarded as permanent operation steps - if you remain in these steps, this will lead to a strong overheating of the hoist motor and the eddy-current brake. Make sure you switch smoothly through these steps.

The hoist unit is likewise equipped with a change-over device SLOW-MIDDLE-FAST. This change over is accomplished over a regulation device on the hoist gear, which will switch over the three speeds mechanically. The switching procedure must only take place at standstill – secured by way of a time delay of 4 sec. during the declaration phase. It is not necessary to lift the brake, nor is it necessary to set the load down when switching over. The selector switch SLOW-MIDDLE-FAST is set to desired position. The indicator lamp CHANGE GEAR will light up as long as this procedure lasts

⚠ When the control lever is returned from lowering or hoisting to zero position, step one switch on automatically for a short time. For the sake of saving the retainer brake, the brake sets after the electrical braking of step one has concluded.

The top and bottom end position of the hook block is monitored by a gear limit switch with cams. There is also a prelimit switch, which will switch off the movement a few meters below max. lifting height in steps 4 and 5. Step 3 is then the highest speed that the hoist movement will to max. permissible lifting height in.

Each position of the selector switch FAST-MIDDLE and SLOW has its own load moment limiter. Releases the maximum load has its own load moment limiter for FAST, the hoist unit can furthermore move in up or down direction only when the selector switch is putted in MIDDLE or SLOW position. If the maximum load limiter has cut off in selector switch position SLOW, it is only possible to set down the load. A special load moment limiter cuts off the up direction when the load exceeds the safe load limit depending of the outreach.

Right side

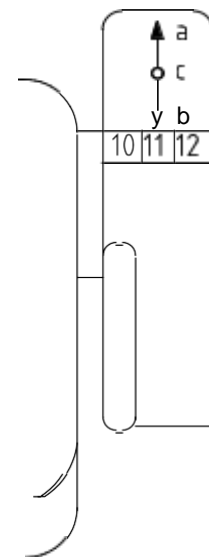

a - lowering
b - lifting
c - dead-man

6.5 Control of luffing unit

The luffing unit is driven by a pole change squirrel cage motor.

The luffing unit is operated by way of the left hand control lever (B) and in 3 steps via contactors. The steps must be switched quickly and smoothly, but do not ever tear.

Each of the end positions is limited by way of a gear control current emergency limit switch. Before one of the end positions is reached a prelimit switch will be activated, which will switch back to step one no matter what position the control lever is in. It is however possible to run out of the end position quickly. This function is taken over by the gear control current switch.

If the jib is driven outwards with load hanging in the hook, the load momentum limiter will be activated as soon as permissible. Either the load is set down or moved inwards again.

Before the luffing unit is switched to zero, it should be switched to step 1 for a short while, until the rpm of this step is reached. When doing so, the unit is slowed down electrically and the mechanical retaining brake is saved from wear.

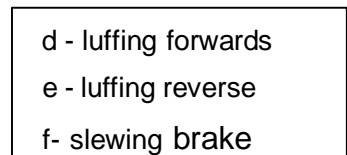

The retaining brake is opened by a DC magnet. The brake is activated without delay as soon as the drive is switched off.

Left side

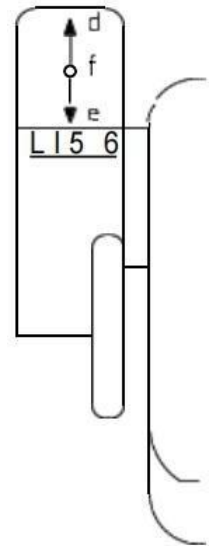

6.6 Control of slewing unit

The slewing unit is driven by a squirrel cage motor with flanged-on eddy current brake.

The slewing unit may not be driven before free positioning (wind) has been neutralized (see paragraph "Safety devices"), so that the retaining brake works again and can brake.

The slewing movement is controlled in 3 steps via the control lever (B).

Steps 1 and 2 should only be used for positioning and corrections over short distances.

If the control lever is switched to zero, the slewing unit will stop slowly, being braked gently. By switching the control lever in counter direction, the slewing unit can be broken over 3 steps. The braking effect is increased from step 1 to step 2 and 3. The crane operator must always take care that the braking action is gentle in order to avoid any impacts and oscillating of the load.

f- Slewing brake g - slewing left h - slewing right

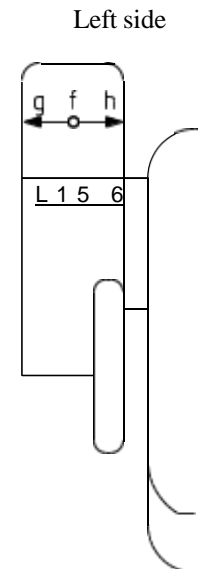

If strong winds threaten to drift the jib away, the retaining brake can be activated by pushing button in the left hand control lever. This is only permitted as long as the slewing unit is as good as at standstill and the control lever is in zero position. When the slewing unit is started, the retaining brake will open automatically.

6.7 Instructions for crane operation



Please always observe the regulations for prevention of accidents (see paragraph "Safety devices").

Switch all drives smoothly and evenly, keep a distance from step to step.



Do not remain in the lower steps, since these steps are starting steps – not steps for crane operation.

Important

The following is forbidden:

1. Any pulling askew when lifting, travelling the crane or luffing and slewing.
2. To tear loose loads that is stuck.
3. Any transport of personnel.
4. Strictly refrain from loading while traveling.



Whenever the crane or any of its drives make any unintentional movements, the strike button "EMERGENCY-OFF" (stop) must be activated immediately.

If the crane operator feels that the crane movement or load movement might lead to danger, he must blow the horn by pushing the appropriate button.



In case of an approaching gale or thunderstorm the crane must be taken out of operation and secured in due course.

6.8 Taking the crane out of operation

In compliance with the regulation for prevention of accidents (VGB 9) the following points are strict provisions, which must be adhered to in all cases:

- Lift the jib in out of service position.
 - Pull up the empty hook block until it is just short of the top end position.
 - Place the jib in wind direction.
 - Release the slewing brake, turn the knurled nut (1) in clockwise direction until it reaches its stop (this also applies for work breaks). The jib must be able to move like a weather vane in the wind.
 - Put all control levers to zero position.
 - Switch off the crane control by pressing the red "mushroom" type button on the control desk before you leave the operator's cabin.
 - Illumination, heating and all connected electrical devices in operator's cabin must be switched off. Lock the operator's seat in working position.
 - Put the main switch within the switch cabinet in zero position.
 - Check all ropes, provide for replacement if this is required (refer to paragraph "Maintenance").
 - Insert the track pinch bars and lock them.
 - All failures and defects noticed during crane operation must be registered in the crane log book and immediate action taken to remedy.
- Furthermore, we recommend the following:

- Switch off the section switch on the mast foot or crane base (if installed).
- All bearing points on winches, running wheels, motors and gears should be checked for any unusually high temperature.

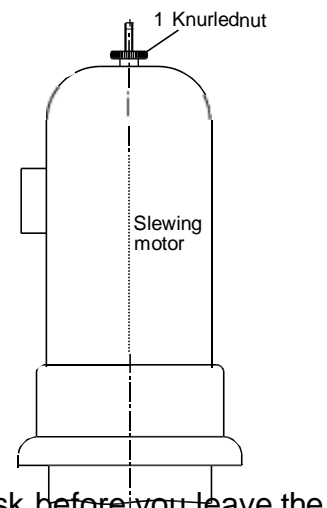

- Make sure all gears are without any leaks.
- Switch off the power connection on the site power distributor.

6.9 Taking the crane out of operation when a gale is approaching

According to DIN 15019 - part 1, cranes must be taken out of operation when the wind speed which corresponds to the total dynamic pressure as calculated from an average based on 10 seconds is exceeded.

The dynamic pressure which represents the top limit can only be considered to correspond to the above calculated dynamic pressure provide the crane operation can be taken out of operation within the shortest possible time and the required safety precautions can be carried out.

When taking the crane out of operation, the following measures must be taken:

- All lifting elements (including ropes and chains) must be let down and the empty hook pulled up.
- Lift the jib in out of service position.
- Slew the jib in wind direction (with the wind).
- Release the slewing brake and provide for free slewability of the crane, or observe corresponding prescriptions.
- Insert all track pinch bars or secure the crane by way of other tying means.

Always follow the approach of local thunderstorms carefully.

The still prior to the first thunder squalls – these usually fall in with enormous wind forces – must be used to put the crane to a favourable position, to take it out of operation and secure it well.

In case the careful weather observation as mentioned above is completed by installing wind measuring devices, such devices should generally be installed at crane's highest point and in any case in such a manner that it will be exposed to the wind equally from all sides without any shading effect. Please observe that the requirements as to wind observation increase the further each outmost dynamic pressure for cranes in operation is reduced, compared to the nominal value of calculated operational dynamic pressure.

The graphic bellow illustrates the relation between the top speed, which is decisive for when the crane must be taken out of operation and the time required to carry out the safety measures as per DIN 15019.

Thereafter the connection between the speed which is decisive for when the crane must be taken out of operation and the required time for carrying out the safety measures is explained.

Calculated dynamic pressure 250 N/qm
Example:

$t=3$ min. time for completion of the safety measures. The crane must be taken out of operation at a wind speed of 64 km/h.

Explained in an easy manner, the following connections can be established:

If 2 min. are required to carry out the safety measures, the crane must be taken out of operation already at a wind speed of 65 km/h.

If 6 min. are required to carry out the safety measures, the crane must be taken out of operation already at a wind speed of 60 km/h.

If 12 min. are required to carry out the safety measures, the crane must be taken out of operation already at a wind speed of 55 km/h.



Do not forget to secure the crane.

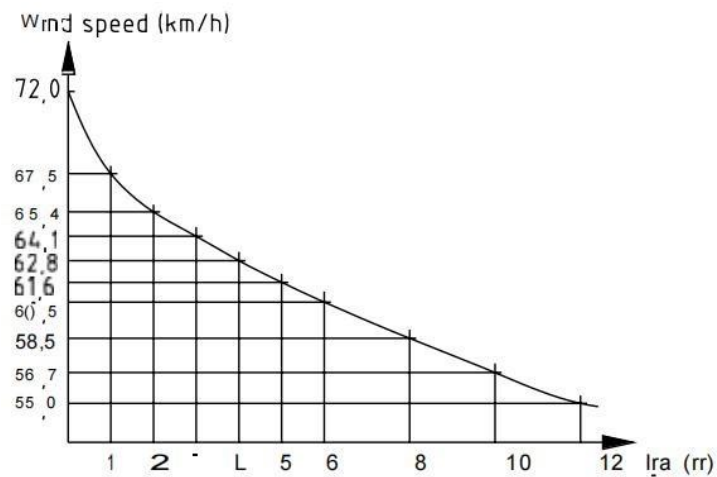

6.10 Changing of the hoist rope reeving from 4-fall rope to 2-fall operation

The crane can work with 2 or 4-fall reeving.



To change the reeving, first push the accomplished button for 2 or 4-fall rope. Then change the hook blocks.

-move both blocks
down to the ground

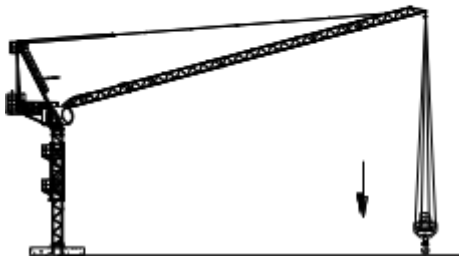

-loose the hoist rope
-open the pin connection
between blocks 1 and 2
-carefully lift block 2

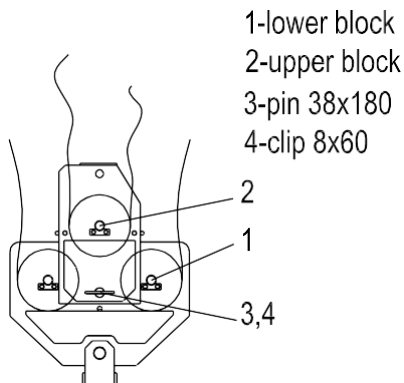
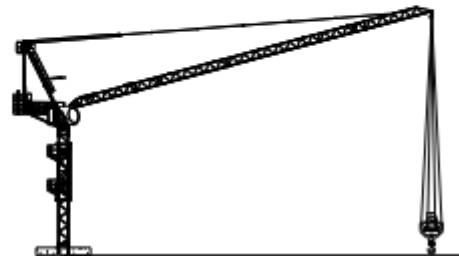

-insert pin 3 into block 1
and secure it with clip 4

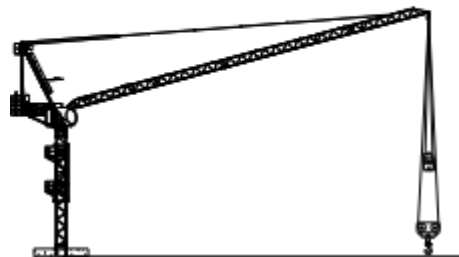

-pull up the upper block 2
-check to make sure the
pulley block 2 is sitting close
to the swing arm

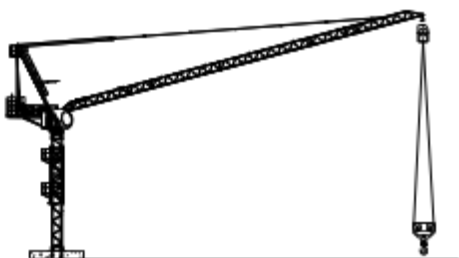

-lift block 1 with hoist rope

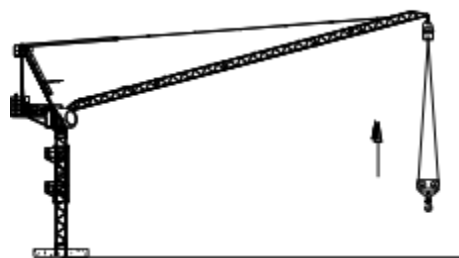

The crane now works with 2-fall rope. The max lifting capacity is 2.5 tons.

6.11 Changing of the hoist rope reeving from 2-fall to 4-fall rope operation

-lower block 1 and sit it to the ground

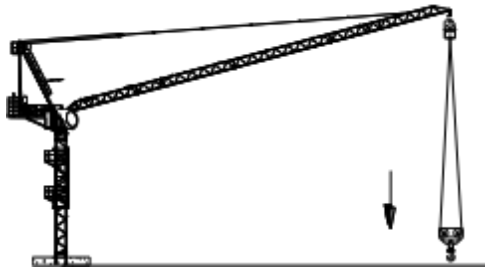

-loosen the hoist rope
-open the pin connection between blocks 1 and 2
-carefully lift block 2

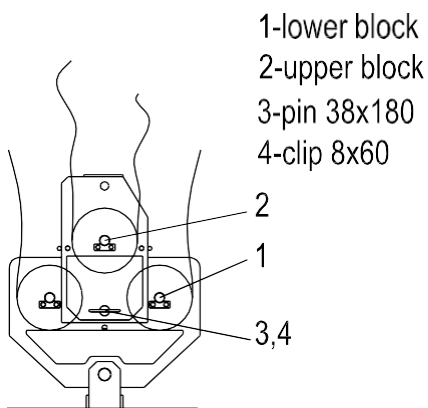
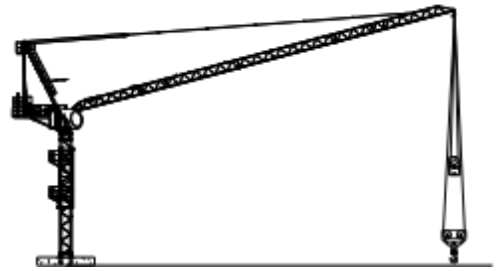

-take out pin 3
-carefully lower block 2 on the block 1

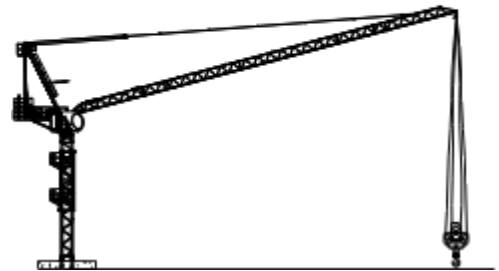

-connect blocks 1 and 2 with pin 3 and secure with clip 4

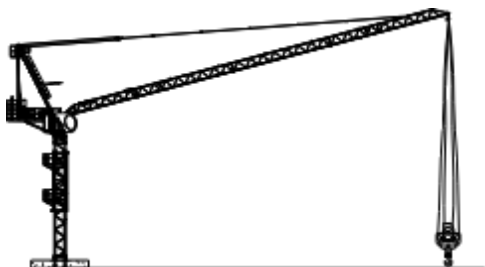

-lift both blocks

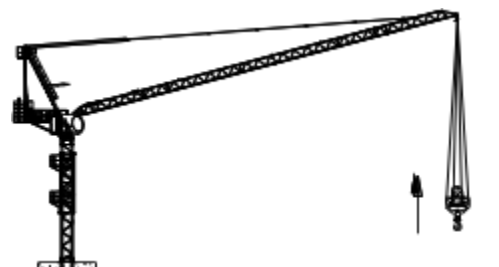

The crane now works with 4-fall rope. Max. capacity in 5.0 tons.

Maintenance**Chapter 7**

7.1 Lubrication – Genera.....	146
7.2 Oil change intervals	146
7.3 Position of lubrication points.....	147
7.4 Lubrication plan.....	147
7.5 Lubricants, operation liquid, quanti	149
7.6 Gear oil	150
7.7 Maintenance schedule	151
7.8 Motors and generator.....	152
7.9 Luffing gea.....	153
7.10 Luffing brake	154
7.11 Switch cabinet – control house.....	154
7.12 Electrical cables.....	155
7.13 Contactor and switch contacts	155
7.14 Emergency limit switch	155
7.15 Slewing ring.....	155
7.16 Shorter lubrication interv	156
7.17 Steel structure.....	156
7.18 Inspection and maintenance of the painting	156
7.19 Supervision of forged load hooks as per DIN 15 401.....	156
7.20 Rope maintenance	157
7.21 Time for replacing wire rop	158
7.22 Drawing-in wire rope	159

7.1 Lubrication - General

The symbols in the lubrication schedule signification the type of lubricant to be used and the different lubrication points. Lubricate thoroughly and regularly, since lubrication carried out according to our instructions helps to prevent failures and premature wear. Clean grease nipples before they are greased and oil drain plugs before they are cleaned. Before each erection, all bolts must be coated with grease. The slewing ring, being subject to the highest stress, has the shortest greasing interval and needs particularly careful maintenance. Do not grease bearings excessively, since they will then overheat during operation. All bearings without grease nipples run without maintenance and are stripped, cleaned and greased with a suitable lubricant as part of the bi-annual general overhaul. Ropes and chains as well as the slewing ring teeth must be treated regularly with acid free grease. All guides on the overload safety device, gear support, brakes and rollers of the limit switches must be kept smooth by coating them with light fluid lubricating oil. Connecting elements which were separated during repair works on the machined surfaces must be treated with a suitable anti-corrosive before they are fitted again. The lubrication intervals stated in the lubrication schedule must be shortened as required when the operational conditions are difficult, so that the crane plant is always in good working order.



Any repair and maintenance work must only be carried out after the crane has been taken out of operation.

7.2 Oil change intervals

Hoist gear	Oil change every 2 years
Slewing gear	
Luffing gear	
Travel gear	
Eldro	Oil change every 15 months
Hydraulics	Oil change every 1200 hours of operation, at least once a year



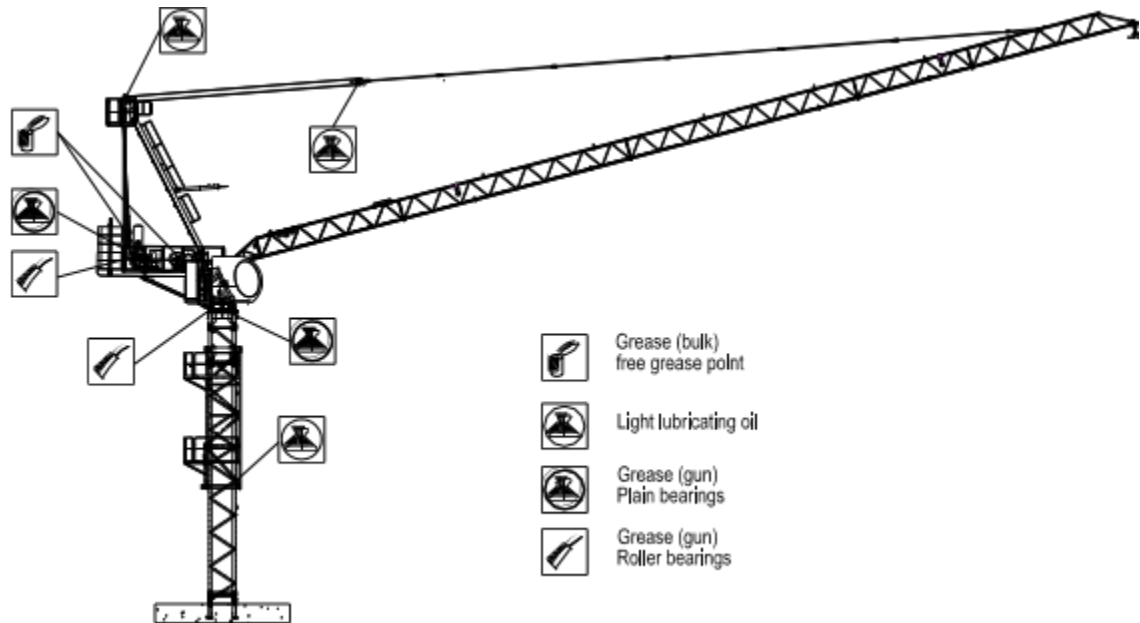

7.3 Position of lubrication points



7.4 Lubrication plan

No		Lubrication positions	Lubricants (see lubricant recommendation)	
1		Toothings at slewing ring	S4	
2		Wheel rims at the wheels	S4	Adhesive lubricant
3				
4		Deflection link chain at joints	S2	
5		Slewing ring	S2	Multipurpose grease
6				
7		Travel wheels	S2	

weekly

8		every 2 weeks	Pivot at travel bogie	S3	
9		every 6 weeks			
10	with grease nipples installed		Brake on hoist gear	S3	
11			Drive axle at slewing gear	S2	
12			Drum and gear bearing pinion shaft travel unit	S2	
13		At least once a year	Roller bearings of gears	S2	
14					
15					
16					
17		prior to each erection (with grease nipples ins	Hinge eye of hydraulic cylinder	S3	
18					
19			Insert all pins freshly greased	S2	
20		as required, prior to each erection	Grease all ropes	S4	Adh. Lubricant
21			Chain drives of limit switches at hoist and luffing unit	S5	Light lubricating oil
22			Keep all joints and guides in running order	S5	

7.5 Lubricants, operation liquid, quantity

Construction pieces and lubricants must be harmonized. Only lubricants shown in the lubricant recommendation for cranes must be used.

	Type	Quantity Liter	Lubricants (see lubricant recommendation)	
Hydraulic unit Climbing device		100	B6*	EP – hydraulic oil
Hoist unit	ZQ500		S1	EP – gear oil
Slewing unit	JH07	..		
Luffing unit	GK 107			
Travelling unit				
Hydraulic double shoe Brake (hoisting unit)			B7	Hydraulic oil
Exposed toothed wheels of slewing connection, running wheel drives and wire ropes.			S4	Adhesive Lubricant
Anti-friction and friction bearings of the rope pulleys, running wheels, drum bearings, chain drives, chain wheels, slewing connection, slip ring transmitter, hook block, greases nipples at gears, drive shaft axles, motors and generators, general lubrication points.			S2	Multipurpose grease
Friction bearings of the travel bogie, central pivot, cross beam, rope suspensions, load hook yokes, brake linkage, jib pivots points.			S3	
All joints and guides at switches and contacts.			S5	Low-viscous Lubricating oil

The oil level must only be measured by standstill of the gear. The oil filling must be reached until the upper marking at oil sight glass or oil overflow screw or until the upper marking at oil stick.



* In countries with tropical climate hydraulic oil ISO VG 68 must be used!

** These gearboxes are permanently greased - maintenance free.

7.6 Gear oil

Oil weight

Ambiente Temperature	Operation under -10°C (without AD*)	Operation between – 10°C to + 50°C				Operation upper + 50°C (without AD*)
		Industrial oil		Car oil		
		(with AD*)	(without AD*)	(with AD*)	(without AD*)	
Viscosity according ISO (SAE)	ISO VG 68	ISO VG 100 (150) No EP ●	ISO VG 150	SAE 30	SAE 80/90	ISO VG 320
AGIP	Balasia 68 (-27°C)	Radula 100	Blasia 150	Super Diesel 15 W/40	Rotra 80 W/90	Blasia 320
BP	Energol GR XP (+/-24°C)	Energol THB 100	Energol GR XP 150	HD SAE 30	Gear oil EP SAE 80	Energol GR XP 320
Cofran	Mecanep 68 GL	Cofraline Equitex 100	Mecanep 150	Equilux C200 super	Cofrapoid 80 W/90	Mecanep 320
ELF	Reductelf SP 68 (-21°C)	Polytelis 100	Reductelf SP 150	Elan SAE 30	Tranself EP 80 W/90	Reductelf SP 320
ESSO	Teresso EPV 32		Spartan EP 150	HDX 30	HDX 30/40	Spartan EP 320
MOBIL	Mobil gear 626 (-24°C)	DTE extra Heavy	Mobil gear 629		Mobilibe C 90	Mobil Gear 632

SHELL	Omala 68 (-24°C)	Tellus 100	Omala 150	Dentax 80	Spirax EP 90	Omala 320
TOTAL	Carter EP 68 (-21°C)	Azolla 100	Carter EP 150	GTS 15 W/40	GTS 15 W/40	Carter EP 320

- No EP: No high pressure oil;

* AD: Recoil shutting Never use high pressure oil in connection with “AD”

7.7 Maintenance schedule

	Maintenance points	Work
daily	Hoist gear, slewing gear luffing and travel gear.	Check oil level
	Hydraulics: Before every new climbing process.	
	Pressure oil pumps	
	Brakes	
After 100 hours	All bolt connections to require torque moment	Check after erection
	Climbing hydraulics oil filter	Replace
Every 50 – 100 hours	Breather filter on the gear	Check
After 200 hours	All connection terminals in the control cabinet	Check for tight seat tighten if necessary
After 1000 hours	Climbing hydraulics: Breather filter	Clean (at least once a year)
	All bolt connections	Check for tight seat and tighten if necessary (at least once a year)
Every 6 weeks	Plungers and rollers of emergency limit switches	Clean and slightly grease
Every 3 months	Vent filter on gear	Check for good working
	Slip rings, collectors, brushes and brush holders of the motor	Clean
	Contact of relays and switches	Check for consumption

Every 6 months	Slip rings : Running surface of slip rings	Clean
	Slip ring : Pivot joints at brush holder levers	Oil lightly with acid-free oil
Yearly	Power cables	Check the outside and replace if necessary
After 2 years General overhaul	Roller bearings of motors and generator	Dismantle and check
	Roller bearings of eddy current brake	Remove and check

This must be done within a short period when the crane has first put in operation. It is necessary to tighten all bolts of the slewing ring with a torque moment spanner. Fastening moment 1000 Nm see table chapter, erection M 27 10.9 DIN 931.

If one of the bolts is not exactly in order it has to be changed. After that check all slewing rings bolts and change them if necessary.

7.8 Motors and generators

Maintenance work must only be carried out when the electric power is shut off.

The motor and Generator roller bearings are given grease fitting in the factory which under normal working conditions will last for approx. 4500 operating hours. The bearings should nevertheless be checked every two years. For this purpose the motor must be dismantled, and the windings, housing and other parts should be cleaned at the same time. Thoroughly wash the bearings with gasoline or benzene. After the gasoline has evaporated, fill the bearings with roller bearing grease.

- To avoid overheating of the bearings due to overfilling, fill only the hollows between the rollers and the roller paths half full with grease. Also coat the shaft passages in the sealing covers with grease.
- Larger motors and generators have greasing nipples and greasing instructions on the identification tag.
- The slip rings, collectors, carbon brushes and brush holders should be checked regularly, at least once every 3 months, depending on frequency of operations. Depending on dirt accumulation (carbon dust), cleaning is best carried out using a suction method.
 - Slight dirt on the contact surfaces should be removed with a non-fibrous wool cloth.
 - No liquid cleaner must be used!
 - Make sure that the slip ring or collectors are smoothly polished and clean.
- The carbon brushes must have a little clearance and lie evenly with their entire contact area and full spring tension on the slip rings or collectors, as appropriate.

- Worn brushes should be replaced by new ones which must be ground into the appropriate rounding with emery cloth.
 - Badly worn and grooved collectors and also brush burns are usually caused by poor maintenance. In such cases a recognized specialist must be called in immediately.
 - This also applies to cleaning procedures in case of very dirty engine interior.
- For additional installation and maintenance information see Appendix A

7.9 Luffing gear

Oil checks and oil change:

All gears requiring oil lubrication are delivered without oil (new cranes); oil must be added. Watch the indication on the housing. Relevant for the oil selection is the oil viscosity suggested on the identification tag at the gearbox. This refers to normal operating conditions.

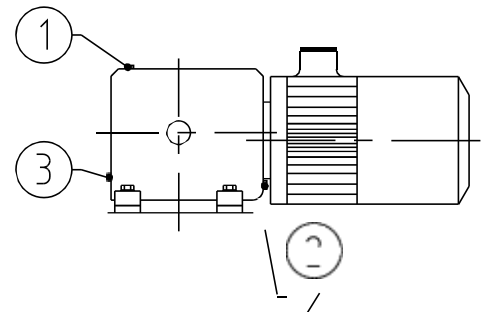

Luffing unit

- | | |
|---|-------------------|
| 1 | Oil filling bolt |
| 2 | Oil drain bolt |
| 3 | Oil overflow bolt |

- Fill in the gear oil through the filling hole until the oil emerges at the oil overflow opening (if installed).
- Check the oil level when the gear is at standstill and the oil is cool.
- Fill in gear oil. For oil change intervals, see "Lubrication schedule", and Appendix B.
- Let out oil immediately after the gear comes to a standstill, so that the oil is still operationally warm. For amount of oil filling, see "operating quantity".
- Before filling in new oil, clean gearbox thoroughly and oil drain plug amply.
- If possible, replace the seal ring at the oil drain plug.

Cleaning of breather filter:

Clean the breather at the gearboxes regularly.

- Screw off the breather, to clean, wash in gasoline and blow out with compressed air.

For additional information refer to Appendix B. 7.9.1

Slewing gear



These gearboxes are permanently greased - maintenance free.

7.10 Luffing brake

The caliper SBD50 disc brake is intended to work mainly as emergency stop brake. For installation and maintenance instructions see Appendix C for further information.

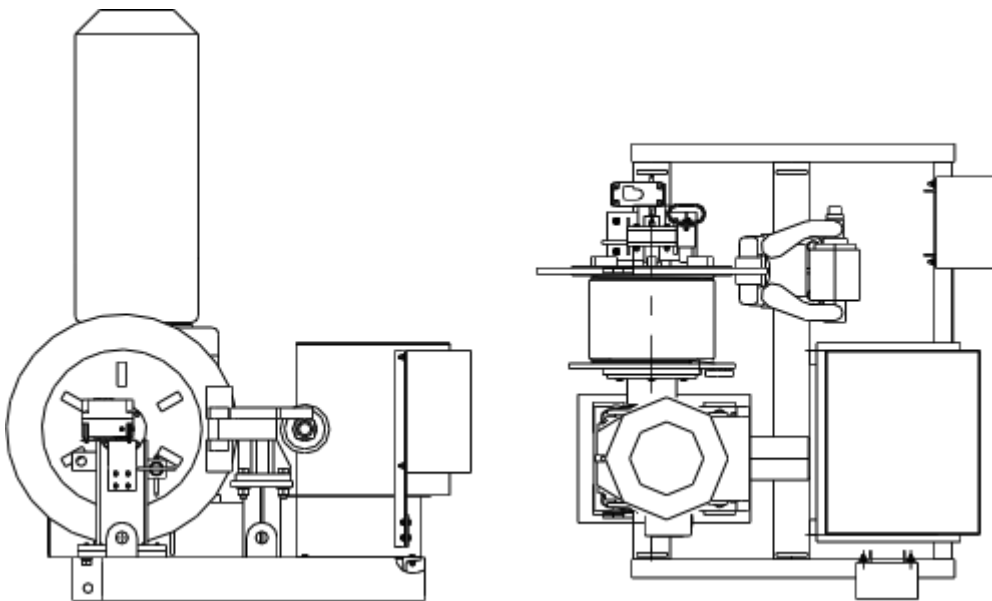

7.11 Switch cabinet - control house

All connection terminals in the switch cabinet and on the electrical devices must be tensioned as described in the maintenance plan. Tension all terminals that are not connected, since dangerous electrical disturbances may occur if contact bolts loosen up. All terminals must be checked after they have been repositioned. Accumulated dust must be removed with compressed air. Do not ever store any tools in the switch cabinet.

7.12 Electrical cables

All cables and lines must be checked as specified in chapter "Maintenance plan" to make sure there is no consumption to be found.

Brittled cables and lines must be replaced by new ones. Be particularly conscious about the feeder line.

7.13 Contactor and switch contacts

Check the contactor and switch contacts for consumption. The contacts have been furnished with a coat of silver; they mate over a large surface without any pushing or sliding movement.

No lubrication, since oil or grease would stimulate the formation of sparks. Argentuous oxide, which is created through the formation of switch fire is fully electrically conducting as opposed to what is the case with copper oxide. The argentuous exode which is created must never be removed. The contacts must bum in such a way that the whole contact surface is engaged in the conduction of current.

Fouling and creation of craters cannot be avoided. Keep contact grease, files and emery cloths away from the contacts. If ever unusual wear should occur (formation of pearls on the contact surfaces), it is absolutely necessary to contact a specialist.

7.14 Emergency limit switches

Clean and grease tappets and rollers of the switches slightly after maintenance work has been completed.

We would recommend using thin-bodied oil for winter operation.

All emergency limit switches must be checked for leaks at the screw connections and cover seals in regular intervals; make sure no water can enter.

7.15 Slewing ring

Greasing of the slewing ring must only be done using a perfect non-acid and resin roller bearing grease and according to the lubricant recommendation for BKT cranes. Press the roller bearing grease into all grease nipples on the slewing ring using a grease press. Thereafter the crane is slewed by approx. 15°, then press in roller bearing grease again. Repeat this process four to five times until grease emerges over the entire circumference of the slewing ring, at the bearing slit. This grease collar serves as a seal and must never be removed.

Greasing intervals: Confer lubrication plan and after every standstill of any length of time.

Whenever blank spots occur on the tothing of the slewing ring it becomes absolutely necessary to regrease.

7.16 Shorter lubrication intervals

In tropical areas, wherever the atmospheric humidity is high, where there is considerable accumulation of dust and dirt, substantial differences in temperature and when the crane is stowed continuously.

When cleaning the slewing ring, please take care that no water runs into the track. After cleaning is completed the slewing ring must be greased thoroughly.

7.17 Steel structure

Bent parts, parts which are cracked or broken must be rectified or replaced immediately. Leave it to the crane manufacturer to decide whether damaged parts as described above can be repaired. Repair weldings on load bearing parts must be carried out by the crane manufacturer. Alternatively a welding specialist from the crane manufacturer or from the technical supervisory authorities of your country must be called in for supervision before the work is started.

7.18 Inspection and maintenance of the painting

From time to time the painting should also be checked as part of the regulations for inspection of the structural steel components to determine their constructional condition. Check whether the priming is shining through, if the paint has become chinky or weather-beaten or if formation of blisters, flaking, considerable chalking, rusty spots or subsurface corrosion has occurred.

The occurrence of rust is to be determined as per DIN 53 2 1 0 "Paintings, determination of rust grade". When maintaining and repairing the painting, please proceed as per DIN 55 928 paragraph 3 and 4.

7.19 Supervision of forged load hooks as per DIN 15 401

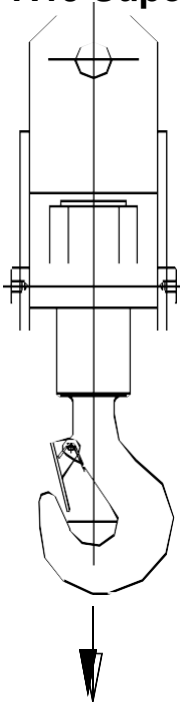

- For drop forged load hooks as per DIN 15 401 sheet 1 and 2 solely visual checks and inspection of the hook mount is sufficient up to and including hook group No. 5. Load hooks must be replaced as soon as their mouth width has increased by more than 10% of max. permissible width a_2 (DIN 15 4301). The same applies when a possible deformation exceeds 1 0% related to the original measure y .
- Further instructions for checks for cracks in the surface, wear and tear and corrosion are given in DIN 15 405 paragraph 5.
- These checks for deformation and wear and tear, e.g. in the hook mount and hook shaft as well as at the transition member must take place as required, however at least once a year.

- Inspection of the transition member as per DIN 685 checked round steel chain item 5.2.1 paragraph b:

Chains which average thickness of member d_m , calculated from the arithmetic average between two diameters standing perpendicularly to each other within the same cross section must be replaced as soon as their nominal thickness has been reduced by more than 10% in any place.

Single members may be replaced. Chains of quenched and subsequently drawn steel must be sent for repair to a factory which is authorized for the supply of such chains.

7.20 Rope maintenance

Correct application, assembly and care lengthen the life of wire ropes considerably. A rusty rope endangers human life. Use rope greases according to the lubricant recommendations for cranes. Ropes with hemp cores must be greased only with liquid lubricants, which creep inside and are acid-free. This prevents the scouring of the hemp fibres by the steel wires and at the same time keeps the hemp core soft and provides for rope flexibility.

Careful greasing of the ropes keeps out humidity, which leads to internal corrosion and growth of bacteria in the hemp. Frequent and light greasing of the ropes gives better results than rare and ample greasing.

As soon as the grease film disappears from some places on the rope, re-greasing becomes necessary. A fixed interval cannot be stated, since in rainy periods more frequent greasing is needed than in dry warm weather. Once a year the rope must be treated with penetrating oil, this renders solidified and crusty greases useful again. Re-greasing must take place only when the rope is completely dry, since otherwise any humidity that maybe present is enclosed in the rope and internal corrosion is promoted. Re-grease with a brush when the drum stands still. The rope taking up the drum curvature is slightly open and this facilitates the penetration of the grease into the rope interior. If necessary, render the lubricant liquid by heating it. Crude oils, petrols, parafins, old oils or other not chemically neutral oils must under no circumstances be used as lubricants.

If the crane is mainly operated in a narrow limited working radius range, an increased danger of damaging the luffing rope in this range arises. Accumulated twist over a short stretch of rope leads to danger of a reinforcement of the twist at the drum approach. This loosens the linkage of the strands and leads to damage.

The service life of a rope which is under such a one-sided stress can only be lengthened when occasionally the possibility to eliminate the twist is given. Therefore the crane should from time to time be operated load free over the whole luffing travel range in order to eliminate the twist in the luffing rope.

Provide for sufficient lubrication of the compensating pulley, the drum and the coiled up and off rope portion.

If peculiarities occur in a rope, then type of lay, rope structure, rope diameter and manufacturer must be determined. The hemp core of the rope contains a coloured thread. The colour arrangement of this thread is the code of the manufacturer.

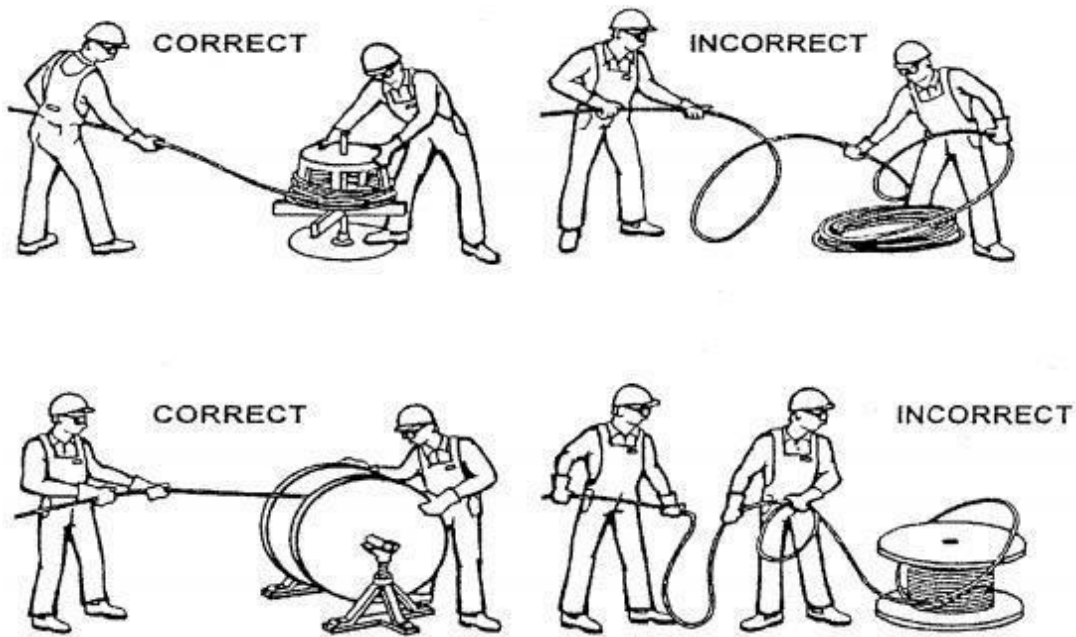

Basket-slacking (nest) of a multi-strand cable (twisting resistant type) caused by forced rotation of the cable reeving through too narrow races or an excessive deviation angle. Increased diameter of a parallel winding cable which is a result of distortion to the metal core due to sudden stress.

Corrosion and signs of wear are often noted on the external wires.

Individual wires bend up and protrude through the strands: serious defect due to alternating stress.



7.21 Time for replacing wire ropes

Safety in crane operation requires that the ropes are replaced in due time. Should the ropes be used longer, the crane operation may become dangerous.

Regardless of the make or the number of single wires, all ropes must be discarded at:

1. Break of a strand
2. Reduction of cross-section by more than 1 0%
3. Rust with grain formation
4. Signs of internal corrosion
5. Contact with live power cables
6. Occurrence of squeezing, bulging, buckling and similar damage.

With breakage of single wires, the number of breakages occurred in the outer strands, related to the rope length determines when the rope is to be replaced.

The following table gives an indication of the time for replacing DIN wire ropes. For specially constructed wire ropes, observe the manufacturer's instructions.

Regular checks of the wire ropes are very important and increase the working safety.

Max. admissible number of wire breakages before the rope must be replaced:

Number of bearing wires in the Outer strands of the rope	51	76	101	121	141	161	181	201	221	
Up to	50	75	100	120	140	160	180	200	220	240
Number of visible wire breakage										
With cross-lay rope: On a length of 6 x rope diameter	2	3	4	5	6	6	7	8	9	1
With cross-lay rope: On a length of 30 x rope diameter	4	6	8	10	11	13	14	16	18	19
With long-lay ropes: On a length of 6 x rope diameter	1	2	2	2	3	3	4	4	4	5
With lon-lay ropes: On a length of 30 x rope diameter	2	3	4	5	6	6	7	8	9	10

Plaited ropes, on the other hand, must be discarded when there are 10 wire breaks per meter,

In case of doubt, consult DIN 15020 sheet 2 (edition of April 1974).

7.22 Drawing-in wire ropes

Putting on wire ropes is to be carried out with particular care only by trained personnel. Before putting on wire it is to be checked if the data on the delivery slip corresponds with those in chapter "rope dimensions". When putting on, all ropes are to be generously greased with rope grease. This also applies to galvanized ropes, since the zinc coating does protect against corrosion, but it does not reduced the internal friction.



The direction of lay of a rope must always be opposite to the pitch of the drum. If this is not observed, you risk the formation of kinkings, rope baskets and/or other rope deformations, making the rope ready for renewal.

The rope should not contact the ground; it must always be resting on a suitable supporting means.

If the rope has not been supplied on a drum, always use a reel for uncoiling. Drawn-in the rope only with the aid of a twistfree leading rope or using the discarded rope. Connect leading rope and rope to be drawn-in a rope stocking. If the old rope is used as a leading rope then connect both rope stockings with a 3 to 4 m long hemp rope. That way any twist existing in the old rope is not transmitted via rope stocking to the new rope. Remove the rope stocking when the rope has been pulled through to the winch. Wind the new rope into the drum with pretension. Pull the rope between two wood blocks clamped together; this is particularly important for multilayer operation. No slack rope must accumulate on the drum.

When renewing the rope at the erected tower, fasten the rope at the fastening point but not before it has been completely drawn in and coiled up on the drum.

Grease the new rope during reeving. Do not immediately load it to maximum; the rope must lengthen gradually. The load twist is distributed by running over pulleys thus improving the running in of the rope. Run new hoist ropes at first with a small load from the lowest to the highest hook position. Subsequently load the rope in slow stages up to maximum load.

During multi-fall reeving of the hoist rope and load-free operation, watch the hook block carefully. If, with cross-lay ropes, the hook block tends to turn in sense of the rope lay, then a twist catcher should be attached which will absorb the twist during a few hoisting with the empty hook. The twist catcher can then be removed again.



After installing the twist catcher, the rope must be regularly inspected for changes (slackening of the outer layer).